ACCESS SERVICE

Regulations, Rates and Charges
applying to the provision of Access Services
for connection to intrastate communications facilities
for customers within the operating territories of

Navajo Communications Company, Inc.

Access Services are provided by means of wire, fiber optics, radio
or any other suitable technology or a combination thereof.

** New or Revised*

Continued

DATE ISSUED: July 31, 2002

EFFECTIVE DATE: September 18, 2002

Aloa J. Stevens
Director – State Government Affairs
Citizens Communications Company
4 Triad Center, Suite 200
Salt Lake City, Utah 84180

ACCESS SERVICE

TABLE OF CONTENTS

	<u>PAGE NO.</u>
<u>CONCURRING CARRIERS</u>	18
<u>CONNECTING CARRIERS</u>	18
<u>OTHER PARTICIPATING CARRIERS</u>	18
<u>REGISTERED SERVICE MARKS</u>	18
<u>REGISTERED TRADEMARKS</u>	18
<u>EXPLANATION OF SYMBOLS</u>	19
<u>EXPLANATION OF ABBREVIATIONS</u>	19
<u>REFERENCE TO OTHER TARIFFS</u>	22
<u>REFERENCE TO TECHNICAL PUBLICATIONS</u>	22

DATE ISSUED: July 31, 2002

EFFECTIVE DATE: September 18, 2002

Aloa J. Stevens
Director – State Government Affairs
Citizens Communications Company
4 Triad Center, Suite 200
Salt Lake City, Utah 84180

ACCESS SERVICE

TABLE OF CONTENTS (Cont'd)

	<u>PAGE NO.</u>
1. <u>APPLICATION OF TARIFF</u>	25
2. <u>GENERAL REGULATIONS</u>	26
2.1 <u>Undertaking of the Telephone Company</u>	26
2.1.1 Scope	26
2.1.2 Limitations	26
2.1.3 Liability	28
2.1.4 Provision of Services	30
2.1.5 Installation and Termination of Services	30
2.1.6 Maintenance of Services	31
2.1.7 Changes, Substitutions, and Rearrangements	31
2.1.8 Refusal and Discontinuance of Service	33
2.1.9 Limitation of Use of Metallic Facilities	34
2.1.10 Notification of Service-Affecting Activities	34
2.1.11 Coordination with Respect to Network Contingencies	35
2.1.12 Provision and Ownership of Telephone Numbers	35
2.1.13 Special Taxes, Fees, Charges	35
2.2 <u>Use</u>	36
2.2.1 Interference or Impairment	36
2.2.2 Unlawful Use	37
2.3 <u>Obligations of the Customer</u>	37
2.3.1 Damages	37
2.3.2 Ownership of Facilities and Theft	37
2.3.3 Equipment Space and Power	38
2.3.4 Availability for Testing	38
2.3.5 Balance	38
2.3.6 Design of Customer Services	39
2.3.7 References to the Telephone Company	39
2.3.8 Claims and Demands for Damages	39
2.3.9 Coordination with Respect to Network Contingencies	40
2.3.10 Sectionalization of Trouble Reporting	41
2.3.11 Identification and Rating of VoIP-PSTN Traffic	41.1 (N)

DATE ISSUED: December 13, 2011

EFFECTIVE DATE: July 30, 2012

Kenneth Mason
Vice President – Government & Regulatory Affairs
Citizens Communications Company
180 S. Clinton Ave.
Rochester, NY 14646

ACCESS SERVICE

TABLE OF CONTENTS (Cont'd)

	<u>PAGE NO.</u>	
2.		<u>GENERAL REGULATIONS (Cont'd)</u>
2.4	41.5	<u>Payment Arrangements and Credit Allowances</u> (T)
2.4.1	41.5	Payment of Rates, Charges and Deposits (T)
2.4.2	50	Minimum Periods
2.4.3	50	Cancellation of an Order for Service
2.4.4	51	Credit Allowance for Service Interruptions
2.4.5	51	Re-establishment of Service Following Fire, Flood, or Other Occurrences
2.4.6	57	Title or Ownership Rights
2.4.7	58	Access Services Provided by More Than One Telephone Company
2.5	65	<u>Connections</u>
2.6	66	<u>Definitions</u>
	66	Access Area
	66	Access Code
	66	Access Minutes
	67	Access Tandem
	67	Access Tandem Network
	67	Answer/Disconnect Supervision
	67	Answer Message
	67	Attenuation Distortion
	67	Balance (100 Type) Test Line
	68	Bit
	68	Business Day
	68	Busy Hour Minutes of Capacity (BHMC)
	68	Call
	69	Carrier or Common Carrier
	69	CCS
	69	Central Office
	69	Central Office Prefix
	69	Centralized Automatic Reporting on Trunks Testing
	69	Circuit(s)
	70	Channel Service Unit

ACCESS SERVICE

TABLE OF CONTENTS (Cont'd)

	<u>PAGE NO.</u>
2. <u>GENERAL REGULATIONS</u> (Cont'd)	
2.6 <u>Definitions</u> (Cont'd)	
Channelize	70
C-Message Noise	70
C-Notched Noise	70
Coin Station	70
Common Channel Signaling System 7 Network (CCS7)	71
Common Line	71
Communications System	71
Customer(s)	71
Data Transmission (107 Type) Test Line	71
Decibel	72
Decibel Reference Noise C-Message Weighting	72
Decibel Reference Noise C-Message Referenced to 0	72
Dual Tone Multifrequency Address Signaling	72
Echo Control	72
Echo Path Loss	73
Echo Return Loss	73
Effective Two-Wire	73
Effective Four-Wire	73
End Office Switch	74
End User	74
Entry Switch	74
Envelope Delay Distortion	74
Equal Level Echo Path Loss	74
Exchange	75
Exit Message	75
Expected Measured Loss	75
Extended Area Service	75
Field Identifier	76
First Come - First Served	76
First Point of Switching	76
Frequency Shift	76
Grandfathered	76
Host Office	77
Immediately Available Funds	77

DATE ISSUED: July 31, 2002

EFFECTIVE DATE: September 18, 2002

Aloa J. Stevens
 Director – State Government Affairs
 Citizens Communications Company
 4 Triad Center, Suite 200
 Salt Lake City, Utah 84180

ACCESS SERVICE

TABLE OF CONTENTS (Cont'd)

	<u>PAGE NO.</u>
2. <u>GENERAL REGULATIONS</u> (Cont'd)	
2.6 <u>Definitions</u> (Cont'd)	
Impedance Balance	77
Impulse Noise	77
Individual Case Basis	77
Initial Address Message (IAM)	78
Inserted Connection Loss	78
Interexchange Carrier (IC) or	
Interexchange Common Carrier	78
Intermodulation Distortion	78
Interstate Communications	78
Intrastate Communications	79
Line Side Connection	79
Local Access and Transport Area	79
Loop Around Test Line	79
Loss Deviation	80
Message	80
Milliwatt (102 Type) Test Line	80
Network Control Signaling	80
Nonsynchronous Test Line	80
North American Numbering Plan	81
Off-hook	81
On-hook	81
Open Circuit Test Line	81
Originating Direction	81
Pay Telephone	81
Phase Jitter	82
Point of Termination	82
Premise(s)	82
Release Message	82
Remote Switching Modules and/or	
Remote Switching Systems	82
Return Loss	82

DATE ISSUED: July 31, 2002

EFFECTIVE DATE: September 18, 2002

Aloa J. Stevens
 Director – State Government Affairs
 Citizens Communications Company
 4 Triad Center, Suite 200
 Salt Lake City, Utah 84180

ACCESS SERVICE

TABLE OF CONTENTS (Cont'd)

	<u>PAGE NO.</u>
2. <u>GENERAL REGULATIONS</u> (Cont'd)	
2.6 <u>Definitions</u> (Cont'd)	
Registered Equipment	83
Serving Wire Center	83
Seven Digit Manual Test Line	83
Shortage of Facilities or Equipment	83
Short Circuit Test Line	83
Signal-To-C-Notched Noise Ratio	84
Signaling System 7 (SS7)	84
Singing Return Loss	84
Subtending End Office of an Access Tandem	84
Synchronous Test Line	84
Terminating Direction	84
Transmission Measuring (105 Type)	
Test Line/Responder	85
Transmission Path	85
Trunk	85
Trunk Group	85
Trunk Side Connection	85
Two-Wire to Four-Wire Conversion	86
Uniform Service Order Code	86
V&H Coordinates Method	86
WATS Serving Office	86
Wire Center	86
3. <u>CARRIER COMMON LINE ACCESS SERVICE</u>	87
3.1 <u>General Description</u>	87
3.2 <u>Limitations</u>	88
3.3 <u>Undertaking of the Telephone Company</u>	89
3.4 <u>Obligations of the Customer</u>	91
3.5 <u>Payment Arrangements</u>	94

DATE ISSUED: July 31, 2002

EFFECTIVE DATE: September 18, 2002

Aloa J. Stevens
Director – State Government Affairs
Citizens Communications Company
4 Triad Center, Suite 200
Salt Lake City, Utah 84180

 ACCESS SERVICE

TABLE OF CONTENTS (Cont'd)

	<u>PAGE NO.</u>	
3.		<u>CARRIER COMMON LINE ACCESS SERVICE</u> (Cont'd)
3.6	97	<u>Payment of Coin Sent-Paid Monies</u>
3.7	100	<u>Rate Regulations</u>
4.	110	<u>RESERVED FOR FUTURE USE</u>
5.	111	<u>ORDERING SWITCHED AND SPECIAL ACCESS</u>
5.1	111	<u>Access Service Request Requirements</u>
5.1.1	112	General
5.1.2	112	Switched Access Ordering Requirements
5.1.3	119	Special Access Services
5.1.4	119	Combined Access Service Arrangements
5.1.5	120	Equal Access Conversions
5.1.6	121	Provision of Other Services
5.1.7	122	Access Order Service Date Intervals
5.1.8	123	Selection of Facilities for Access Order
5.1.9	123	Shared Use Facilities
5.2	124	<u>Access Services Provided by More Than One Telephone Company</u>
5.3	126	<u>Access Order Charges</u>
5.3.1	126	Access Service Request Modifications
5.3.2	130	Cancellation of an Access Service Request
5.3.3	132	Minimum Period Charges
6.	134	<u>SWITCHED ACCESS SERVICE</u>
6.1	134	<u>General</u>
6.2	134	<u>Language Exceptions</u>

(T)

DATE ISSUED: May 9, 2012

EFFECTIVE DATE: July 1, 2012

Kenneth Mason
 Vice President – Government & Regulatory Affairs
 Citizens Communications Company
 180 S. Clinton Ave.
 Rochester, NY 14646

ACCESS SERVICE

TABLE OF CONTENTS (Cont'd)

	<u>PAGE NO.</u>
6. <u>RESERVED FOR FUTURE USE</u>	(T)
	(D)
	(D)

ACCESS SERVICE

TABLE OF CONTENTS (Cont'd)

	<u>PAGE NO.</u>	
6. <u>RESERVED FOR FUTURE USE</u>		(T)
		(D)
		(D)
7. <u>SPECIAL ACCESS SERVICES</u>	341	
7.1 <u>Provision of Special Access Service</u>	343	
7.1.1 Circuit Types	343	
7.1.2 Service Configurations	345	
7.1.3 Technical Specifications Packages	349	
7.1.4 Channel Interfaces	350	
7.1.5 Alternate Use	351	
7.1.6 Special Facilities Routing	352	
7.1.7 Design Layout Report	352	
7.1.8 Acceptance Testing	352	

DATE ISSUED: May 9, 2012

EFFECTIVE DATE: July 1, 2012

Kenneth Mason
 Vice President – Government & Regulatory Affairs
 Citizens Communications Company
 180 S. Clinton Ave.
 Rochester, NY 14646

ACCESS SERVICE

TABLE OF CONTENTS (Cont'd)

	<u>PAGE NO.</u>
7. <u>SPECIAL ACCESS SERVICES (Cont'd)</u>	
7.2 <u>Rate Categories, Applications, and Regulations</u>	353
7.2.1 Rate Categories	353
7.2.2 Minimum Periods	362
7.2.3 Application of Daily and Monthly Rates	362
7.2.4 Facility Hubs and Multiplexing	363
7.2.5 Shared Use Analog and Digital High Capacity Services	365
7.3 <u>Metallic Service</u>	366
7.3.1 Basic Circuit Description	366
7.3.2 Technical Specifications Packages	367
7.3.3 Channel Interfaces	367
7.3.4 Optional Features and Functions	367
7.4 <u>Voice Grade Service</u>	369
7.4.1 Basic Circuit Description	369
7.4.2 Technical Specifications Packages	370
7.4.3 Channel Interfaces	371
7.4.4 Optional Features and Functions	371
7.5 <u>Program Audio Service</u>	380
7.5.1 Basic Circuit Description	380
7.5.2 Technical Specifications Packages	380
7.5.3 Channel Interfaces	381
7.5.4 Optional Features and Functions	381
7.6 <u>Video Service</u>	383
7.6.1 Basic Circuit Description	383
7.6.2 Technical Specifications Packages	383
7.6.3 Channel Interfaces	385
7.7 <u>Wideband Analog Service</u>	386
7.7.1 Basic Circuit Description	386
7.7.2 Technical Specifications Packages	386
7.7.3 Channel Interfaces	387
7.7.4 Optional Features and Functions	387

DATE ISSUED: July 31, 2002

EFFECTIVE DATE: September 18, 2002

Aloa J. Stevens
Director – State Government Affairs
Citizens Communications Company
4 Triad Center, Suite 200
Salt Lake City, Utah 84180

ACCESS SERVICE

TABLE OF CONTENTS (Cont'd)

	<u>PAGE NO.</u>
7. <u>SPECIAL ACCESS SERVICES (Cont'd)</u>	
7.8 <u>Digital Data Service</u>	389
7.8.1 Basic Circuit Description	389
7.8.2 Technical Specifications Packages	389
7.8.3 Channel Interfaces	390
7.8.4 Optional Features and Functions	390
7.9 <u>High Capacity Service</u>	391
7.9.1 Basic Circuit Description	391
7.9.2 Technical Specifications Packages	391
7.9.3 Channel Interfaces	392
7.9.4 Optional Features and Functions	392
8. <u>MISCELLANEOUS SERVICES</u>	396
8.1 <u>Additional Engineering</u>	396
8.2 <u>Additional Labor</u>	397
8.2.1 Overtime Installation	398
8.2.2 Overtime Repair	398
8.2.3 Stand By	398
8.2.4 Maintenance with Other Telephone Companies	398
8.2.5 Other Labor	398

DATE ISSUED: July 31, 2002

EFFECTIVE DATE: September 18, 2002

Aloa J. Stevens
Director – State Government Affairs
Citizens Communications Company
4 Triad Center, Suite 200
Salt Lake City, Utah 84180

ACCESS SERVICE

TABLE OF CONTENTS (Cont'd)

	<u>PAGE NO.</u>	
8.		<u>MISCELLANEOUS SERVICES</u>
8.3	399	<u>Maintenance of Service</u>
8.4	400	<u>Additional Testing</u>
8.5	403	<u>Presubscription</u>
8.6	408	<u>Miscellaneous Equipment</u>
8.7	409	<u>Telecommunications Service Priority</u> (T)
8.8	409	<u>Standard Jacks - Registration Program</u>
9.		<u>INTERFACE GROUPS, TRANSMISSION SPECIFICATIONS, AND CHANNEL CODES</u>
9.1	410	<u>Local Transport Interface Groups</u>
9.1.1	411	Interface Group 1 (USOC TPP1X)
9.1.2	412	Interface Group 2 (USOC TPP2X)
9.1.3	412	Interface Group 3 (USOC TPP3X)
9.1.4	412	Interface Group 4 (USOC TPP4X)
9.1.5	413	Interface Group 5 (USOC TPP5X)
9.1.6	413	Interface Group 6 (USOC TPP6X)
9.1.7	414	Interface Group 7 (USOC TPP7X)
9.1.8	415	Interface Group 8 (USOC TPP8X)
9.1.9	415	Interface Group 9 (USOC TPP9X)
9.1.10	416	Interface Group 10 (USOC TPPAX)
9.1.11	416	Available Premises Interface Codes

DATE ISSUED:

EFFECTIVE DATE:

Aloa J. Stevens
 Director – Government & External Affairs
 Citizens Communications Company
 P.O. Box 708970
 Sandy, Utah 84070

ACCESS SERVICE

TABLE OF CONTENTS (Cont'd)

	<u>PAGE NO.</u>
9. <u>INTERFACE GROUPS, TRANSMISSION SPECIFICATIONS, AND CHANNEL CODES (CONT'D)</u>	
9.2 <u>Transmission Specifications for Switched Access Service</u>	420
9.2.1 Standard Transmission Specifications	427
9.2.2 Data Transmission Parameters	428
9.3 <u>Channel Interface and Network Channel Codes</u>	431
9.3.1 Glossary of Channel Interface Codes and Options	432
9.3.2 Impedance	439
9.3.3 Digital Hierarchy Channel Interface Codes (4DS)	440
9.3.4 Service Designator/Network Channel Code Conversion Table	440
9.3.5 Compatible Channel Interfaces	443
10. <u>SPECIAL FEDERAL GOVERNMENT ACCESS SERVICES</u>	458
10.1 <u>General</u>	458
10.2 <u>Emergency Conditions</u>	458
10.3 <u>Intervals to Provide Service</u>	459
10.4 <u>Safeguarding of Service</u>	459
10.4.1 Facility Availability	459
10.5 <u>Federal Government Regulations</u>	460
10.6 <u>Service Offerings to the Federal Government</u>	460
10.6.1 Type and Description	460
10.6.2 Mileage Application	464
10.6.3 Rates and Charges	465

DATE ISSUED: July 31, 2002

EFFECTIVE DATE: September 18, 2002

Aloa J. Stevens
Director – State Government Affairs
Citizens Communications Company
4 Triad Center, Suite 200
Salt Lake City, Utah 84180

ACCESS SERVICE

TABLE OF CONTENTS (Cont'd)

	<u>PAGE NO.</u>
11. <u>SPECIAL FACILITIES ROUTING OF ACCESS SERVICES</u>	467
11.1 <u>Description of Special Facilities Routing of Access Services</u>	467
11.1.1 Diversity	467
11.1.2 Avoidance	467
11.1.3 Cable-Only Facilities	467
11.2 <u>Rates and Charges for Special Facilities Routing of Access Services</u>	468
11.2.1 Diversity	468
11.2.2 Avoidance	468
11.2.3 Diversity and Avoidance Combined	469
11.2.4 Cable-Only Facilities	469
12. <u>SPECIALIZED SERVICE OR ARRANGEMENTS</u>	470
12.1 <u>General</u>	471
12.2 <u>Rates and Charges</u>	470
13. <u>EXCEPTIONS TO ACCESS SERVICE OFFERINGS</u>	471
14. <u>SPECIAL CONSTRUCTION</u>	472
14.1 <u>Application of Tariff</u>	472
14.2 <u>Regulations</u>	472
14.2.1 Filing of Charges	472
14.2.2 Ownership of Facilities	472
14.2.3 Interval to Provide Facilities	472
14.2.4 Special Construction Involving Both Interstate and Intrastate Facilities	473
14.2.5 Payments for Special Construction	473
14.2.6 Liabilities and Charges for Special Construction	474
14.2.7 Deferral of Start of Service	487
14.2.8 Definitions	488
14.3 Charges to Provide Permanent Facilities	491

DATE ISSUED: July 31, 2002

EFFECTIVE DATE: September 18, 2002

Aloa J. Stevens
Director – State Government Affairs
Citizens Communications Company
4 Triad Center, Suite 200
Salt Lake City, Utah 84180

ACCESS SERVICE

TABLE OF CONTENTS (Cont'd)

	<u>PAGE NO.</u>	
15. <u>WIRE CENTER AND INTERCONNECTION INFORMATION</u>	492	
15.1 <u>Serving Wire Center V and H Coordinate Information - Arizona</u>	492	
15.2 <u>Single State Interconnection Information - Arizona</u>	523	
16. <u>RATES AND CHARGES</u>	532	
16.1 <u>Carrier Common Line</u>	532	
16.2 <u>Switched Access Service</u>	533	
16.3 <u>Special Federal Government Access Services</u>	544	(D)
16.3.1 Voice Grade Special Access Service	544	
16.3.2 Wideband Digital Special Access Service	545	(D)
16.3.3 Special Routing Access Services	545	
16.4 <u>Special Facilities Routing of Access Services</u>	546	
16.4.1 Diversity	546	
16.4.2 Avoidance	546	
16.4.3 Diversity and Avoidance Combined	546	
16.4.4 Cable-Only Facilities	546	
16.5 <u>Specialized Service or Arrangements</u>	546	
16.6 <u>Special Access Rates and Charges</u>	547	
16.6.1 Metallic Service	547	
16.6.2 Voice Grade Service	548	
16.6.3 Program Audio Service	554	
16.6.4 Video Service	556	
16.6.5 Wideband Analog Service	558	
16.6.6 Digital Data Service	560	
16.6.7 High Capacity Service	563	
16.6.8 Individual Case Filing	567	

DATE ISSUED: May 9, 2012

EFFECTIVE DATE: July 1, 2012

Kenneth Mason
Vice President – Government & Regulatory Affairs
Citizens Communications Company
180 S. Clinton Ave.
Rochester, NY 14646

ACCESS SERVICE

TABLE OF CONTENTS (Cont'd)

	<u>PAGE NO.</u>	
16. <u>RATES AND CHARGES</u> (Cont'd)		
16.7 <u>Miscellaneous Services</u>	568	
16.7.1 Charges for Additional Engineering	568	
16.7.2 Charges for Additional Labor	568	
16.7.3 Charges for Additional Testing	569	
16.7.4 Presubscription Charge	569	
16.7.5 Protective Connecting Arrangements	570	
16.7.6 Controller Arrangement	575	
16.7.7 Telecommunications Service Priority	575	(T)
16.7.8 Standard Jacks – Registration Program	576	
17. <u>ARIZONA UNIVERSAL SERVICE FUND</u>	582	

DATE ISSUED:
EFFECTIVE DATE: _
FILED BY: Aloa J. Stevens
 Director

SECTION BELOW RESERVED FOR
ACC TARIFF APPROVAL
APPROVED FOR FILING
IN COMPLIANCE WITH
DECISION NO. 65472

ACCESS SERVICE

CONCURRING CARRIERS

NO CONCURRING CARRIERS

CONNECTING CARRIERS

NO CONNECTING CARRIERS

OTHER PARTICIPATING CARRIERS

NO OTHER PARTICIPATING CARRIERS

REGISTERED SERVICE MARKS REGISTERED TRADEMARKS

NONE

NONE

** New or Revised*

Continued

DATE ISSUED: July 31, 2002
2002

EFFECTIVE DATE: September 18,

Aloa J. Stevens
Director – State Government Affairs
Citizens Communications Company
4 Triad Center, Suite 200
Salt Lake City, Utah 84180

ACCESS SERVICE

EXPLANATION OF SYMBOLS

- (C) - To signify changed regulation
- (D) - To signify discontinued rate or regulation
- (I) - To signify increase
- (L) - To signify matter relocated without change
- (N) - To signify new rate or regulation
- (R) - To signify reduction
- (S) - To signify reissued matter
- (T) - To signify a change in text but no change in rate or regulation
- (Z) - To signify a correction

EXPLANATION OF ABBREVIATIONS

- a.c. - alternating current
- AML - Actual Measured Loss
- ANI - Automatic Number Identification
- AP - Program Audio
- ASR - Access Service Request
- AT&T - American Telephone and Telegraph Company
- BD - Business Day
- BHMC - Busy Hour Minutes of Capacity
- CAROT - Centralized Automatic Reporting on Trunks
- CCS7 - Common Channel Signaling System 7
- CI - Changes Interface
- CO - Central Office
- COCTX - Central Office Centrex
- Cont'd - Continued
- CPE - Customer Provided Equipment
- Ctx - Centrex
- dB - decibel
- dBrnC - Decibel Reference Noise C-Message Weighting
- dBrnCO - Decibel Reference Noise C-Message Weighted O
- dBv - Decibel(s) Relative to 1 Volt (Reference)
- dBv1 - Decibel(s) Relating to 1 Volt (Reference)
- d.c. - direct current

* *New or Revised**Continued*DATE ISSUED: July 31, 2002
2002

EFFECTIVE DATE: September 18,

Aloa J. Stevens
Director – State Government Affairs
Citizens Communications Company
4 Triad Center, Suite 200
Salt Lake City, Utah 84180

ACCESS SERVICE

EXPLANATION OF ABBREVIATIONS (Cont'd)

EDD	-	Envelope Delay Distortion
ELEPL	-	Equal Level Echo Path Loss
EML	-	Expected Measured Loss
EPL	-	Echo Path Loss
ERL	-	Echo Return Loss
ESS	-	Electric Switching System
ESSX	-	Electric Switching System Exchange
f	-	frequency
FID	-	Field Identifier
FCC	-	Federal Communications Commission
FX	-	Foreign Exchange
HC	-	High Capacity
Hz	-	Hertz
IC	-	Interexchange Carrier
ICB	-	Individual Case Basis
ICL	-	Inserted Connection Loss
KBPS	-	Kilobits per second
KHZ	-	Kilohertz
LATA	-	Local Access and Transport Area
Ma	-	Milliamperes
Mbps	-	Megabits per second
MF	-	Multifrequency
MHz	-	Megahertz
MMUC	-	Minimum Monthly Usage Charge
MRC	-	Monthly Recurring Charge
MT	-	Metallic
MTS	-	Message Telecommunications Service(s)
NPA	-	Numbering Plan Area
NRC	-	Nonrecurring Charge
NTS	-	Non-Traffic Sensitive
NXX	-	Three-Digit Central Office Code
OTPL	-	Zero Transmission Level Point
PBX	-	Private Branch Exchange
PCM	-	Pulse Code Modulation
PLR	-	Private Line Ringdown

* *New or Revised**Continued*DATE ISSUED: July 31, 2002
2002

EFFECTIVE DATE: September 18,

Aloa J. Stevens
 Director – State Government Affairs
 Citizens Communications Company
 4 Triad Center, Suite 200
 Salt Lake City, Utah 84180

ACCESS SERVICE

EXPLANATION OF ABBREVIATIONS (Cont'd)

POT	-	Point of Termination
rms	-	root-mean-square
RSM	-	Remote Switching Modules
RSS	-	Remote Switching Systems
SRL	-	Singing Return Loss
SS7	-	Signaling System 7
SSN	-	Switched Service Network
SWC	-	Serving Wire Center
TES	-	Telephone Exchange Service(s)
TLP	-	Transmission Level Point
TSPS	-	Traffic Service Position System
TV	-	Television
USOC	-	Uniform Service Order Code
VG	-	Voice Grade
V & H	-	Vertical & Horizontal
WA	-	Wideband Analog
WATS	-	Wide Area Telecommunications Service(s)
WD	-	Wideband Data

** New or Revised**Continued*DATE ISSUED: July 31, 2002
2002

EFFECTIVE DATE: September 18,

Aloa J. Stevens
Director – State Government Affairs
Citizens Communications Company
4 Triad Center, Suite 200
Salt Lake City, Utah 84180

ACCESS SERVICE

REFERENCE TO OTHER TARIFFS

Whenever reference is made in this tariff to other tariffs of the Telephone Company, the reference is to the tariffs in force as of the effective date of this tariff, and to amendments thereto and successive issues thereof.

REFERENCE TO TECHNICAL PUBLICATIONS

The following technical publications are referenced in this tariff and may be obtained from Bellcore, Customer Service, 60 New England Avenue, Room 18252, Piscataway, N.J. 08854-4196.

Compatibility Bulletin 106, Issue 2

Issued: December, 1981

Available: March 11, 1982

Technical Reference:

PUB 41451 High Capacity Terrestrial Digital Service

Issued: January, 1983

Available: May 17, 1983

PUB 60101

Issued: December, 1982

Available: January 17, 1983

PUB 41004 Data Communications Using Voiceband Private Line Channels

Issued: October, 1973

Available: October, 1973

PUB 62310 Digital Data System Channel Interface Specification

Issued: September, 1983

Available: October, 1983

PUB 62411 High Capacity Digital Service Channel Interface Specifications

Issued: September, 1983

Available: October, 1983

TR-NPL-000334 Voice Grade Switched Access Service

Issued: June, 1986

Available: July, 1986

TR-NPL-000335 Voice Grade Special Access Service

Issued: June, 1986

Available: July, 1986

TR-TSV-000905 Bellcore Technical Reference Publication Issue 1

Issued: August, 1989

Available: August, 1989

** New or Revised*

Continued

DATE ISSUED: July 31, 2002
2002

EFFECTIVE DATE: September 18,

Aloa J. Stevens
Director – State Government Affairs
Citizens Communications Company
4 Triad Center, Suite 200
Salt Lake City, Utah 84180

ACCESS SERVICE

REFERENCE TO TECHNICAL PUBLICATIONS (Cont'd)

PUB 62501 Addendum Voice Grade Special Access Service
Issued: March, 1984 Available: April, 1984

PUB 62502 Narrowband Special Access Service
Issued: December, 1983 Available: January, 1984

PUB 62503 Program Audio Special Access Service
Issued: December, 1983 Available: March 15, 1984

PUB 62503 Addendum Program Audio Special Access Service
Issued: March, 1984 Available: April, 1984

PUB 62504 Television Special Access Service
Issued: December, 1983 Available: March 15, 1984

PUB 62504 Addendum Television Special Access Service
Issued March, 1984 Available: April, 1984

PUB 62505 Wideband Analog Special Access Service
Issued: December, 1983 Available: January, 1984

PUB 62505 Addendum Wideband Analog Special Access Service
Issued March, 1984 Available: April, 1984

PUB 62506 Wideband Digital Special Access Service
Issued: December, 1983 Available: January, 1984

PUB 62507 Digital Data Special Access Service
Issued: December, 1983 Available: March 15, 1984

PUB 62508 High Capacity Digital Special Access Service
Issued: December, 1983 Available: January, 1984

** New or Revised**Continued*DATE ISSUED: July 31, 2002
2002

EFFECTIVE DATE: September 18,

Aloa J. Stevens
Director – State Government Affairs
Citizens Communications Company
4 Triad Center, Suite 200
Salt Lake City, Utah 84180

ACCESS SERVICE

REFERENCE TO TECHNICAL PUBLICATIONS (Cont'd)

The following technical publication is referenced in this tariff and may be obtained from the Bell Communications Technical Education Center, Room B02, 6200 Route 53, Lisle, IL 60532.

Telecommunications Transmission Engineering
Volume 3 - Networks and Services (Chapter 6 and 7)
Second Edition, 1980
Issued: June, 1980 Available: June, 1980

The following Technical Publication is referenced in this tariff and may be obtained from the National Exchange Carrier Association, Inc., Director - Tariff and Regulatory Matters, 100 So. Jefferson Road, Whippany, NJ 07981 and the Federal Communications Commission's commercial contractor.

PUB AS No. 1, Issue II
Issued: May, 1984 Available: May, 1984
Addendum: March, 1987 Available: March, 1987

The following tariff is referenced in this tariff and may be obtained from the Federal Communications Commission's commercial contractor.

National Exchange Carrier Association
Tariff FCC No. 4

** New or Revised*

Continued

DATE ISSUED: July 31, 2002
2002

EFFECTIVE DATE: September 18,

Aloa J. Stevens
Director – State Government Affairs
Citizens Communications Company
4 Triad Center, Suite 200
Salt Lake City, Utah 84180

ACCESS SERVICE

Check Sheet

Pages 1 to 469 of this tariff are effective as of the date shown. The original and revised pages named below contain all changes from the original tariff that are in effect on the date shown.

<u>Page</u>	<u>Number of Revision Except As Indicated</u>	<u>Page</u>	<u>Number of Revision Except As Indicated</u>	<u>Page</u>	<u>Number of Revision Except As Indicated</u>
Title 1	Original	33	Original	61	Original
1	15 th Revised*	34	Original	62	Original
2	2 nd Revised	35	1 st Revised	63	Original
3	2 nd Revised	36	Original	64	1 st Revised
4	2 nd Revised	37	Original	65	Original
5	2 nd Revised	38	Original	66	Original
6	14 th Revised*	39	Original	67	Original
7	Original	40	Original	68	Original
8	1 st Revised	41	1 st Revised	69	Original
9	1 st Revised	41.1	Original	70	Original
10	1 st Revised	41.2	Original	71	Original
11	Original	41.3	Original	72	1 st Revised
12	Original	41.4	Original	73	1 st Revised
13	Original	41.5	Original	74	Original
14	Original	42	Original	75	Original
15	Original	43	Original	76	Original
16	1 st Revised	44	Original	77	Original
17	1 st Revised	45	Original	78	Original
18	Original	46	Original	79	Original
19	Original	47	Original	80	Original
20	Original	48	Original	81	Original
21	Original	49	Original	82	Original
22	Original	50	Original	83	Original
23	Original	51	1 st Revised	84	Original
24	Original	52	Original	85	Original
25	Original	53	Original	86	Original
26	Original	54	Original	87	Original
27	Original	55	Original	88	Original
28	Original	56	Original	89	1 st Revised
29	Original	57	Original	90	Original
30	Original	58	Original		
31	Original	59	Original		
32	Original	60	Original		

* New or Revised

Continued

Issued: May 17, 2023

Effective: July 1, 2023

Senior Compliance Manager
Compliance

Check Sheet (Cont'd)

<u>Page</u>	Number of Revision Except <u>As Indicated</u>	<u>Page</u>	Number of Revision Except <u>As Indicated</u>	<u>Page</u>	Number of Revision Except <u>As Indicated</u>
91	Original	124	Original	157	1 st Revised*
92	Original	125	Original	158	1 st Revised*
93	Original	126	Original	159	1 st Revised*
94	Original	127	Original	160	1 st Revised*
95	Original	128	Original	161	1 st Revised*
96	Original	129	Original	162	1 st Revised*
97	Original	130	Original	163	1 st Revised*
98	Original	131	Original	164	1 st Revised*
99	Original	132	Original	165	1 st Revised*
100	Original	133	1 st Revised*	166	1 st Revised*
101	Original	134	1 st Revised*	167	1 st Revised*
102	1 st Revised*	135	1 st Revised*	168	1 st Revised*
103	Original	136	1 st Revised*	169	1 st Revised*
104	Original	137	1 st Revised*	170	1 st Revised*
105	Original	138	1 st Revised*	171	1 st Revised*
106	Original	139	1 st Revised*	172	1 st Revised*
107	1 st Revised*	140	1 st Revised*	173	1 st Revised*
108	Original	141	1 st Revised*	174	1 st Revised*
109	1 st Revised*	142	1 st Revised*	175	1 st Revised*
110	Original	143	1 st Revised*	176	1 st Revised*
111	Original	144	1 st Revised*	177	1 st Revised*
112	Original	145	1 st Revised*	178	1 st Revised*
113	Original	146	1 st Revised*	179	1 st Revised*
114	Original	147	1 st Revised*	180	1 st Revised*
115	1 st Revised*	148	1 st Revised*	181	1 st Revised*
116	Original	149	1 st Revised*	182	1 st Revised*
117	Original	150	1 st Revised*	183	1 st Revised*
118	1 st Revised*	151	1 st Revised*	184	1 st Revised*
119	1 st Revised*	152	1 st Revised*	185	1 st Revised*
120	1 st Revised*	153	1 st Revised*	186	1 st Revised*
121	Original	154	1 st Revised*	187	1 st Revised*
122	Original	155	1 st Revised*	188	1 st Revised*
123	Original	156	1 st Revised*	189	1 st Revised*

* New or Revised

Continued

DATE ISSUED: May 9, 2012

EFFECTIVE DATE: July 1, 2012

Kenneth Mason
Vice President – Government & Regulatory Affairs
Citizens Communications Company
180 S. Clinton Ave.
Rochester, NY 14646

Check Sheet (Cont'd)

<u>Page</u>	Number of Revision Except <u>As Indicated</u>	<u>Page</u>	Number of Revision Except <u>As Indicated</u>	<u>Page</u>	Number of Revision Except <u>As Indicated</u>
190	1 st Revised*	223	1 st Revised*	256	1 st Revised*
191	1 st Revised*	224	1 st Revised*	257	1 st Revised*
192	1 st Revised*	225	1 st Revised*	258	1 st Revised*
193	1 st Revised*	226	1 st Revised*	259	1 st Revised*
194	1 st Revised*	227	1 st Revised*	260	1 st Revised*
195	1 st Revised*	228	1 st Revised*	261	1 st Revised*
196	1 st Revised*	229	1 st Revised*	262	1 st Revised*
197	1 st Revised*	230	1 st Revised*	263	1 st Revised*
198	1 st Revised*	231	1 st Revised*	264	1 st Revised*
199	1 st Revised*	232	1 st Revised*	265	1 st Revised*
200	1 st Revised*	233	1 st Revised*	266	1 st Revised*
201	1 st Revised*	234	1 st Revised*	267	1 st Revised*
202	1 st Revised*	235	1 st Revised*	268	1 st Revised*
203	1 st Revised*	236	1 st Revised*	269	1 st Revised*
204	1 st Revised*	237	1 st Revised*	270	1 st Revised*
205	1 st Revised*	238	1 st Revised*	271	1 st Revised*
206	1 st Revised*	239	1 st Revised*	272	1 st Revised*
207	1 st Revised*	240	1 st Revised*	273	1 st Revised*
208	1 st Revised*	241	1 st Revised*	274	1 st Revised*
209	1 st Revised*	242	1 st Revised*	275	1 st Revised*
210	1 st Revised*	243	1 st Revised*	276	1 st Revised*
211	1 st Revised*	244	1 st Revised*	277	1 st Revised*
212	1 st Revised*	245	1 st Revised*	278	1 st Revised*
213	1 st Revised*	246	1 st Revised*	279	1 st Revised*
214	1 st Revised*	247	1 st Revised*	280	1 st Revised*
215	1 st Revised*	248	1 st Revised*	281	1 st Revised*
216	1 st Revised*	249	1 st Revised*	282	1 st Revised*
217	1 st Revised*	250	1 st Revised*	283	1 st Revised*
218	1 st Revised*	251	1 st Revised*	284	1 st Revised*
219	1 st Revised*	252	1 st Revised*	285	1 st Revised*
220	1 st Revised*	253	1 st Revised*	286	1 st Revised*
221	1 st Revised*	254	1 st Revised*	287	1 st Revised*
222	1 st Revised*	255	1 st Revised*	288	1 st Revised*

* New or Revised

Continued

DATE ISSUED: May 9, 2012

EFFECTIVE DATE: July 1, 2012

Kenneth Mason
Vice President – Government & Regulatory Affairs
Citizens Communications Company
180 S. Clinton Ave.
Rochester, NY 14646

Check Sheet (Cont'd)

<u>Page</u>	Number of Revision Except <u>As Indicated</u>	<u>Page</u>	Number of Revision Except <u>As Indicated</u>	<u>Page</u>	Number of Revision Except <u>As Indicated</u>
289	1 st Revised	322	1 st Revised	355	Original
290	1 st Revised	323	1 st Revised	356	Original
291	1 st Revised	324	1 st Revised	357	Original
292	1 st Revised	325	1 st Revised	358	Original
293	1 st Revised	326	1 st Revised	359	Original
294	1 st Revised	327	1 st Revised	360	Original
295	1 st Revised	328	1 st Revised	361	Original
296	1 st Revised	329	1 st Revised	362	Original
297	1 st Revised	330	1 st Revised	363	Original
298	1 st Revised	331	1 st Revised	364	Original
299	1 st Revised	332	1 st Revised	365	Original
300	1 st Revised	333	1 st Revised	366	Original
301	1 st Revised	334	1 st Revised	367	Original
302	1 st Revised	335	1 st Revised	368	Original
303	1 st Revised	336	1 st Revised	369	1 st Revised
304	1 st Revised	337	1 st Revised	370	Original
305	1 st Revised	338	1 st Revised	371	Original
306	1 st Revised	339	1 st Revised	372	Original
307	1 st Revised	340	1 st Revised	373	Original
308	1 st Revised	341	1 st Revised	374	Original
309	1 st Revised	342	1 st Revised	375	Original
310	1 st Revised	343	Original	376	Original
311	1 st Revised	344	Original	377	Original
312	1 st Revised	345	1 st Revised	378	Original
313	1 st Revised	346	Original	379	Original
314	1 st Revised	347	Original	380	Original
315	1 st Revised	348	Original	381	Original
316	1 st Revised	349	Original	382	Original
317	1 st Revised	350	Original	383	Original
318	1 st Revised	351	Original	384	Original
319	1 st Revised	352	Original	385	Original
320	1 st Revised	353	Original	386	Original
321	1 st Revised	354	2 nd Revised*	387	Original

* New or Revised

Continued

Issued: January 15, 2015

Allison Ellis
Vice President, Regulatory Affairs
3 High Ridge Park
Stamford, CT 06905

Effective: February 16, 2015

ACCESS SERVICE

Check Sheet (Cont'd)

<u>Page</u>	Number of Revision Except <u>As Indicated</u>	<u>Page</u>	Number of Revision Except <u>As Indicated</u>	<u>Page</u>	Number of Revision Except <u>As Indicated</u>
388	Original	424	Original	460	Original
389	Original	425	Original	461	Original
390	Original	426	Original	462	Original
391	Original	427	Original	463	Original
392	Original	428	1 st Revised*	464	Original
393	Original	429	Original	465	Original
394	Original	430	Original	466	Original
395	Original	431	Original	467	Original
396	1 st Revised*	432	Original	468	Original
397	Original	433	Original	469	Original
398	Original	434	Original	470	Original
399	Original	435	Original	471	Original
400	1 st Revised*	436	Original	472	Original
401	Original	437	Original	473	Original
402	Original	438	Original	474	Original
403	Original	439	Original	475	Original
404	1 st Revised*	440	Original	476	Original
405	Original	441	Original	477	Original
406	Original	442	Original	478	Original
407	Original	443	Original	479	Original
408	Original	444	Original	480	Original
409	Original	445	Original	481	Original
410	1 st Revised*	446	Original	482	Original
411	Original	447	Original	483	Original
412	Original	448	Original	484	Original
413	Original	449	Original	485	Original
414	Original	450	Original	486	Original
415	Original	451	Original	487	Original
416	Original	452	Original	488	Original
417	Original	453	Original	489	Original
418	Original	454	Original	490	Original
419	Original	455	Original	491	Original
420	1 st Revised*	456	Original	492	Original
421	Original	457	Original	493	Original
422	Original	458	Original	494	Original
423	Original	459	Original	495	Original

* New or Revised

Continued

DATE ISSUED: May 9, 2012

EFFECTIVE DATE: July 1, 2012

Kenneth Mason
Vice President – Government & Regulatory Affairs
Citizens Communications Company
180 S. Clinton Ave.
Rochester, NY 14646

ACCESS SERVICE

Check Sheet

<u>Page</u>	Number of Revision Except <u>As Indicated</u>	<u>Page</u>	Number of Revision Except <u>As Indicated</u>	<u>Page</u>	Number of Revision Except <u>As Indicated</u>
496	Original	530	Original	564	Original
497	Original	531	Original	565	Original
498	Original	532	3 rd Revised	566	Original
499	Original	533	6 th Revised*	567	Original
500	Original	534	1 st Revised	568	Original
501	Original	535	1 st Revised	569	Original
502	Original	536	1 st Revised	570	Original
503	Original	537	1 st Revised	571	Original
504	Original	538	1 st Revised	572	Original
505	Original	539	1 st Revised	573	Original
506	Original	540	1 st Revised	574	Original
507	Original	541	1 st Revised	575	2 nd Revised
508	Original	542	1 st Revised	576	Original
509	Original	543	1 st Revised	577	Original
510	Original	544	Original	578	Original
511	Original	545	Original	579	Original
512	Original	546	Original	580	Original
513	Original	547	Original	581	Original
514	Original	548	Original	582	4 th Revised
515	Original	549	Original		
516	Original	550	Original		
517	Original	551	Original		
518	Original	552	Original		
519	Original	553	Original		
520	Original	554	Original		
521	Original	555	Original		
522	Original	556	Original		
523	Original	557	Original		
524	Original	558	Original		
525	Original	559	Original		
526	Original	560	Original		
527	Original	561	Original		
528	Original	562	Original		
529	Original	563	Original		

* *New or Revised**Continued*

DATE ISSUED: May 17, 2023

EFFECTIVE DATE: July 1, 2023

Senior Compliance Manager
Compliance

ACCESS SERVICE

1. Application of Tariff

- 1.1 This tariff contains regulations, rates, and charges applicable to the provision of Carrier Common Line, Switched Access, and Special Access Services, and other miscellaneous services, hereinafter referred to collectively as service(s), provided by Navajo Communications Company, Inc., hereinafter referred to as the Telephone Company, to customers.
- 1.2 The provision of such services by the Telephone Company as set forth in this tariff does not constitute a joint undertaking with the customer for the furnishing of any service.

** New or Revised*

Continued

DATE ISSUED: July 31, 2002

EFFECTIVE DATE: September 18, 2002

Aloa J. Stevens
Director – State Government Affairs
Citizens Communications Company
4 Triad Center, Suite 200
Salt Lake City, Utah 84180

ACCESS SERVICE

2. General Regulations

2.1 Undertaking of the Telephone Company

2.1.1 Scope

- (A) The Telephone Company does not undertake to transmit messages under this tariff.
- (B) The Telephone Company shall be responsible only for the installation, operation, and maintenance of the services it provides.
- (C) The Telephone Company will, for maintenance purposes, test its services only to the extent necessary to detect and/or clear troubles.
- (D) Services are provided 24 hours daily, seven days per week, except as set forth in other applicable sections of this tariff.
- (E) The Telephone Company does not warrant that its facilities and services meet standards other than those set forth in this tariff.

2.1.2 Limitations

- (A) The customer may not assign or transfer the use of services provided under this tariff; however, where there is no interruption of use or relocation of the services, such assignment or transfer may be made to:
 - (1) Another customer, whether an individual, partnership, association, or corporation, provided the assignee or transferee assumes all outstanding indebtedness for such services, and the unexpired portion of the minimum period and the termination liability applicable to such services, if any; or

** New or Revised*

Continued

DATE ISSUED: July 31, 2002

EFFECTIVE DATE: September 18, 2002

Aloa J. Stevens
Director – State Government Affairs
Citizens Communications Company
4 Triad Center, Suite 200
Salt Lake City, Utah 84180

ACCESS SERVICE

2. General Regulations (Cont'd)2.1 Undertaking of the Telephone Company (Cont'd)2.1.2 Limitations (Cont'd)

(A) (Cont'd)

- (2) a court-appointed receiver, trustee, or other person acting pursuant to law in bankruptcy, receivership, reorganization, insolvency, liquidation, or other similar proceedings, provided the assignee or transferee assumes the unexpired portion of the minimum period and the termination liability applicable to such services, if any.

In all cases of assignment or transfer, the written acknowledgment of the Telephone Company is required prior to such assignment or transfer which acknowledgment shall be made within 15 days from the receipt of notification. All rates, regulations, and conditions contained in this tariff shall apply to such assignee or transferee.

The assignment or transfer of services does not relieve or discharge the assignor or transferor from remaining jointly or severally liable with the assignee or transferee for any obligation existing at the time of the assignment or transfer.

- (B) The use and restoration of services shall be in accordance with Part 64, Subpart D, Appendix A, of the Federal Communications Commission's Rules and Regulations, which specifies the priority system for such activities.
- (C) Subject to compliance with the rules mentioned in (B) preceding, the services offered herein will be provided to customers on a first-come, first-served basis, except as outlined in (D) following.

* *New or Revised*

Continued

DATE ISSUED: July 31, 2002

EFFECTIVE DATE: September 18, 2002

Aloa J. Stevens
Director – State Government Affairs
Citizens Communications Company
4 Triad Center, Suite 200
Salt Lake City, Utah 84180

ACCESS SERVICE

2. General Regulations (Cont'd)2.1 Undertaking of the Telephone Company (Cont'd)2.1.2 Limitations (Cont'd)

- (D) When an end office is scheduled to be converted to an equal access end office, and a shortage of facilities exists, the Telephone Company will allocate available resources to participating ICs as set forth in Section 5.1.5(A) following.

2.1.3 Liability

- (A) The Telephone Company's liability, if any, for its willful misconduct is not limited by this tariff. With respect to any other claim or suit, by a customer or by any others, for damages associated with the installation, provision, termination, maintenance, repair, or restoration, of service, and subject to the provisions of (B) through (H) following, the Telephone Company's liability if any, shall not exceed an amount equal to the proportionate charge for the service for the period during which the service was affected. This liability for damages shall be in addition to any amounts that may otherwise be due the customer under this tariff as a Credit Allowance for a Service Interruption.
- (B) The Telephone Company shall not be liable for any act or omission of any other carrier or customer providing a portion of a service, nor shall the Telephone Company for its own act or omission hold liable any other carrier or customer providing a portion of a service.
- (C) The Telephone Company is not liable for damages to the customer premises resulting from the furnishing of a service, including the installation and removal of equipment and associated wiring, unless the damage is caused by the Telephone Company's negligence.

* *New or Revised*

Continued

DATE ISSUED: July 31, 2002

EFFECTIVE DATE: September 18, 2002

Aloa J. Stevens
Director – State Government Affairs
Citizens Communications Company
4 Triad Center, Suite 200
Salt Lake City, Utah 84180

ACCESS SERVICE

2. General Regulations (Cont'd)2.1 Undertaking of the Telephone Company (Cont'd)2.1.3 Liability (Cont'd)

- (D) The Telephone Company shall be indemnified, defended, and held harmless by the IC or end user against any claim, loss, or damage arising from the IC or end user's use of services offered under this tariff, involving:
- (1) Claims for libel, slander, invasion of privacy, or infringement of copyright arising from the IC or end user's own communications.
 - (2) Claims for patent infringement arising from the customer's acts combining or using the service furnished by the Telephone Company in connection with facilities or equipment furnished by the IC or end user or;
 - (3) All other claims arising out of any act or omission of the IC or end user in the course of using services provided pursuant to this tariff.
- (E) The Telephone Company does not guarantee or make any warranty with respect to its services when used in an explosive atmosphere. The Telephone Company shall be indemnified, defended, and held harmless by the customer from any and all claims by any person relating to such customer's use of services so provided.
- (F) No license under patents (other than the limited license to use) is granted by the Telephone Company or shall be implied or arise by estoppel, with respect to any service offered under this tariff.

** New or Revised**Continued*

DATE ISSUED: July 31, 2002

EFFECTIVE DATE: September 18, 2002

Aloa J. Stevens
Director – State Government Affairs
Citizens Communications Company
4 Triad Center, Suite 200
Salt Lake City, Utah 84180

ACCESS SERVICE

2. General Regulations (Cont'd)

2.1 Undertaking of the Telephone Company (Cont'd)

2.1.3 Liability (Cont'd)

- (G) The Telephone Company will defend the customer against claims of patent infringement arising solely from the use by the customer of services offered under this tariff and will indemnify such customer for any damages awarded based solely on such claims.
- (H) The Telephone Company's failure to provide or maintain services under this tariff shall be excused by labor difficulties, governmental orders, civil commotions, criminal actions taken against the Telephone Company, acts of God, and other circumstances beyond the Telephone Company's reasonable control, subject to the Credit Allowance for a Service Interruption as set forth in 2.4.4 following.

2.1.4 Provision of Services

The Telephone Company, to the extent that such services are or can be made available with reasonable effort, and after provision has been made for the Telephone Company's telephone exchange services, will provide to the customer upon reasonable notice services offered in other applicable sections of this tariff at rates and charges specified therein.

2.1.5 Installation and Termination of Services

The services provided under this tariff (A) will include any entrance cable or drop wiring and wire or intrabuilding cable to that point where provision is made for termination of the Telephone Company's outside distribution network facilities at

** New or Revised*

Continued

DATE ISSUED: July 31, 2002

EFFECTIVE DATE: September 18, 2002

Aloa J. Stevens
Director – State Government Affairs
Citizens Communications Company
4 Triad Center, Suite 200
Salt Lake City, Utah 84180

ACCESS SERVICE

2. General Regulations (Cont'd)

2.1 Undertaking of the Telephone Company (Cont'd)

2.1.5 Installation and Termination of Services (Cont'd)

a location at the customer designated premises and (B) will be installed by the Telephone Company to such Point of Termination. The Telephone Company will work cooperatively with the customer to determine the location of the Point of Termination in accordance with the Telephone Company's standard operating procedures.

Each Access Service has only one Point of Termination per customer premises. Any additional terminations beyond such Point of Termination are the sole responsibility of the customer. Moves of the Point of Termination are handled as set forth in Section 6 following.

2.1.6 Maintenance of Services

The services provided under this tariff shall be maintained by the Telephone Company. The customer or others may not rearrange, move, disconnect, remove, or attempt to repair any facilities provided by the Telephone Company, other than by connection or disconnection to any interface means used, except with the written consent of the Telephone Company.

2.1.7 Changes, Substitutions and Rearrangements

Except as provided for equipment and systems subject to FCC Part 68 Regulations at 47 C.F.R Section 68.110(b), the Telephone Company may, where such action is reasonably required in the operation of its business;

** New or Revised*

Continued

DATE ISSUED: July 31, 2002

EFFECTIVE DATE: September 18, 2002

Aloa J. Stevens
Director – State Government Affairs
Citizens Communications Company
4 Triad Center, Suite 200
Salt Lake City, Utah 84180

ACCESS SERVICE

2. General Regulations (Cont'd)2.1 Undertaking of the Telephone Company (Cont'd)2.1.7 Changes, Substitutions and Rearrangements (Cont'd)

- (A) Substitute, change, or rearrange any facilities used in providing service under this tariff, including but not limited to;
- (1) substitution of different metallic facilities,
 - (2) substitution of carrier or derived facilities for metallic facilities used to provide other than metallic facilities, and
 - (3) substitution of metallic facilities for carrier or derived facilities used to provide other than metallic facilities; and
 - (4) change in the routing of access service traffic.
- (B) Change minimum protection criteria;
- (C) Change operating or maintenance characteristics of facilities or,
- (D) Change operations or procedures of the Telephone Company.

In case of any such substitution, change, or rearrangement, the transmission parameters will be within the range as set forth in Sections 6, 7 and 9 following. The Telephone Company shall not be responsible if any such substitution, change, or rearrangement renders any customer furnished services obsolete or requires modification or alteration thereof

* *New or Revised*

Continued

DATE ISSUED: July 31, 2002

EFFECTIVE DATE: September 18, 2002

Aloa J. Stevens
Director – State Government Affairs
Citizens Communications Company
4 Triad Center, Suite 200
Salt Lake City, Utah 84180

ACCESS SERVICE

2. General Regulations (Cont'd)

2.1 Undertaking of the Telephone Company (Cont'd)

2.1.7 Changes, Substitutions and Rearrangements (Cont'd)

or otherwise affects their use or performance. If such substitution, change, or rearrangement materially affects the operating characteristics of the facility, the Telephone Company will provide reasonable notification to the customer in writing. Reasonable time will be allowed for any redesign and implementation required by the change in operating characteristics. The Telephone Company will work cooperatively with the customer to determine reasonable notification procedures.

2.1.8 Refusal and Discontinuance of Service

Unless the provisions of 2.2.1(B) or 2.5 following apply, if a customer fails to comply with the regulations set forth in: 2.1.6, Maintenance of Services; 2.2.2, Unlawful Use; 2.3.1, Damages; 2.3.4, Availability for Testing; 2.3.5, Balance; and 2.4, Payment Arrangements and Credit Allowances; or fails to make any payment to be made by it on the dates and times herein specified, the Telephone Company may, on thirty (30) days written notice by Certified U.S. Mail to the person designated by that customer to receive such notices of noncompliance:

- (a) Refuse additional applications for service and/or refuse to complete any pending orders for service by the noncomplying customer; and/or
- (b) Discontinue the provision of the services to the noncomplying customer. In the case of such discontinuance, all applicable charges including termination charges shall become due.

** New or Revised*

Continued

DATE ISSUED: July 31, 2002

EFFECTIVE DATE: September 18, 2002

Aloa J. Stevens
Director – State Government Affairs
Citizens Communications Company
4 Triad Center, Suite 200
Salt Lake City, Utah 84180

ACCESS SERVICE

2. General Regulations (Cont'd)

2.1 Undertaking of the Telephone Company (Cont'd)

2.1.8 Refusal and Discontinuance of Service (Cont'd)

If the Telephone Company does not refuse additional applications for service on the date specified in the thirty (30) days notice given pursuant to (a) above, or does not discontinue its provision of services involved on the date specified in the thirty (30) day notice given pursuant to (b) above and the customer's noncompliance continues, nothing contained herein shall preclude the Telephone Company's right to refuse additional applications for service to the noncomplying customer without further notice.

2.1.9 Limitation of Use of Metallic Facilities

Signals applied to a metallic facility shall conform to the limitations set forth in Technical Reference Publication AS No. 1. In the case of applications of d.c. telegraph signaling systems, the customer shall be responsible, at its expense, for the provision of current limiting devices to protect the Telephone Company facilities from excessive current due to abnormal conditions and for the provision of noise mitigation networks when required to reduce excessive noise.

2.1.10 Notification of Service-Affecting Activities

The Telephone Company will provide the customer reasonable notification of service-affecting activities that may occur in normal operation of its business. Such activities may include, but are not limited to, equipment or facilities additions, removals or rearrangements, routine preventative maintenance, and major switching machine change-out. Generally, such activities are not individual customer service specific; they

** New or Revised*

Continued

DATE ISSUED: July 31, 2002

EFFECTIVE DATE: September 18, 2002

Aloa J. Stevens
Director – State Government Affairs
Citizens Communications Company
4 Triad Center, Suite 200
Salt Lake City, Utah 84180

ACCESS SERVICE

2. General Regulations (Cont'd)2.1 Undertaking of the Telephone Company (Cont'd)2.1.10 Notification of Service-Affecting Activities (Cont'd)

affect many customer services. No specific advance notification period is applicable to all service-affecting activities. The Telephone Company will work cooperatively with the customer to determine the notification requirements.

2.1.11 Coordination with Respect to Network Contingencies

The Telephone Company intends to work cooperatively with the customer to develop network contingency plans in order to maintain maximum network capability following natural or man-made disasters which affect telecommunications services.

2.1.12 Provision and Ownership of Telephone Numbers

The Telephone Company reserves the reasonable right to assign, designate, or change telephone numbers, any other call number designations associated with Access Services, or the Telephone Company serving central office prefixes associated with such numbers, when necessary in the conduct of its business. Should it become necessary to make a change in such number(s), the Telephone Company will furnish to the customer 6 months notice, by Certified U.S. Mail, of the effective date and an explanation of the reason(s) for such change(s).

2.1.13 Special Fees, Taxes, Charges

Insofar as practicable, any sales, use, privilege, excise, franchise or occupation tax, costs of furnishing service without charge or similar taxes or impositions now or hereafter levied by the Federal, State, or Local government or any political subdivision or taxing authority thereof may be billed by the Company to its customers on a pro rata basis in the areas wherein such taxes, impositions or other charges shall be levied against the Company.

(N)

(N)

* New or Revised

Continued

DATE ISSUED: July 22, 2005

EFFECTIVE DATE: August 22, 2005

Aloa J. Stevens
 Director – State Government Affairs
 Citizens Communications Company
 4 Triad Center, Suite 200
 Salt Lake City, Utah 84180

ACCESS SERVICE

2. General Regulations (Cont'd)

2.2 Use

2.2.1 Interference or Impairment

- (A) The characteristics and methods of operation of any circuits, facilities, or equipment provided by other than the Telephone Company and associated with the facilities utilized to provide services under this tariff shall not interfere with or impair service over any facilities of the Telephone Company, its affiliated companies, or its connecting and concurring carriers involved in its services, cause damage to their plant, impair the privacy of any communications carried over their facilities or create hazards to the employees of any of them or the public.

- (B) Except as provided for equipment or systems subject to the FCC Part 68 Rules in 47 C.F.R Section 68.108, if such characteristics or methods of operation are not in accordance with (A) preceding, the Telephone Company will, where practicable, notify the customer that temporary discontinuance of the use of a service may be required; however, where prior notice is not practicable, nothing contained herein shall be deemed to preclude the Telephone Company's right to temporarily discontinue forthwith the use of a service if such action is reasonable under the circumstances. In case of such temporary discontinuance, the customer will be promptly notified and afforded the opportunity to correct the condition which gave rise to the temporary discontinuance. During such period of temporary discontinuance, credit allowance for service interruptions as set forth in 2.4.4 following is not applicable.

** New or Revised*

Continued

DATE ISSUED: July 31, 2002

EFFECTIVE DATE: September 18, 2002

Aloa J. Stevens
Director – State Government Affairs
Citizens Communications Company
4 Triad Center, Suite 200
Salt Lake City, Utah 84180

ACCESS SERVICE

2. General Regulations (Cont'd)

2.2 Use (Cont'd)

2.2.2 Unlawful Use

The service provided under this tariff shall not be used for an unlawful purpose.

2.3 Obligations of the Customer

2.3.1 Damages

The customer shall reimburse the Telephone Company for damages to Telephone Company facilities utilized to provide services under this tariff caused by the negligence or willful act of the customer, or resulting from the customer's improper use of the Telephone Company facilities, or due to malfunction of any facilities or equipment provided by other than the Telephone Company. Nothing in the foregoing provision shall be interpreted to hold one customer liable for another customer's actions. The Telephone Company will, upon reimbursement for damages, cooperate with the customer in prosecuting a claim against the person causing such damage and the customer shall be subrogated to the right of recovery by the Telephone Company for the damages to the extent of such payment.

2.3.2 Ownership of Facilities and Theft

Facilities utilized by the Telephone Company to provide service under the provisions of this tariff shall remain the property of the Telephone Company. Such facilities shall be returned to the Telephone Company by the customer, whenever requested, within a reasonable period following the request in as good condition as reasonable wear will permit.

** New or Revised*

Continued

DATE ISSUED: July 31, 2002

EFFECTIVE DATE: September 18, 2002

Aloa J. Stevens
Director – State Government Affairs
Citizens Communications Company
4 Triad Center, Suite 200
Salt Lake City, Utah 84180

ACCESS SERVICE

2. General Regulations (Cont'd)

2.3 Obligations of the Customer (Cont'd)

2.3.3 Equipment Space and Power

The customer shall furnish or arrange to have furnished to the Telephone Company, at no charge, equipment space and electrical power required by the Telephone Company to provide services under this tariff at the points of termination of such services. The selection of a.c. or d.c. power shall be mutually agreed to by the customer and the Telephone Company. The customer shall also make necessary arrangements in order that the Telephone Company will have access to such spaces at reasonable times for installing, testing, repairing, or removing Telephone Company services.

2.3.4 Availability for Testing

The services provided under this tariff shall be available to the Telephone Company at times mutually agreed upon in order to permit the Telephone Company to make tests and adjustments appropriate for maintaining the services in satisfactory operating condition. Such tests and adjustments shall be completed within a reasonable time. No credit will be allowed for any interruptions involved during such tests and adjustments.

2.3.5 Balance

All signals for transmission over the services provided under this tariff shall be delivered by the customer balanced to ground except for ground start, duplex (DX) and McCulloh-Loop (Alarm System) type signaling and d.c. telegraph transmission at speeds of 75 baud or less.

** New or Revised*

Continued

DATE ISSUED: July 31, 2002

EFFECTIVE DATE: September 18, 2002

Aloa J. Stevens
Director – State Government Affairs
Citizens Communications Company
4 Triad Center, Suite 200
Salt Lake City, Utah 84180

ACCESS SERVICE

2. General Regulations (Cont'd)

2.3 Obligations of the Customer (Cont'd)

2.3.6 Design of Customer Services

Subject to the provisions of 2.1.7 preceding, the customer shall be solely responsible, at its own expense, for the overall design of its services and for any redesigning or rearrangement of its services which may be required because of changes in facilities, operations, or procedures of the Telephone Company, minimum protection criteria or operating or maintenance characteristics of the facilities.

2.3.7 References to the Telephone Company

The customer may advise end users that certain services are provided by the Telephone Company in connection with the service the customer furnishes to end users; however, the customer shall not represent that the Telephone Company jointly participates in the customer's services.

2.3.8 Claims and Demands for Damages

- (A) With respect to claims of patent infringement made by third persons, the customer shall defend, indemnify, protect, and save harmless the Telephone Company from and against all claims arising out of the combining with, or use in connection with, the services provided under this tariff, any circuit, apparatus, system, or method provided by the customer.
- (B) The customer shall defend, indemnify, and save harmless the Telephone Company from and against any suits, claims, losses, or damages, including punitive damages, attorney fees, and court costs by third persons arising out of the construction, installation, operation, maintenance, or removal of the customer's circuits, facilities, or

** New or Revised*

Continued

DATE ISSUED: July 31, 2002

EFFECTIVE DATE: September 18, 2002

Aloa J. Stevens
Director – State Government Affairs
Citizens Communications Company
4 Triad Center, Suite 200
Salt Lake City, Utah 84180

ACCESS SERVICE

2. General Regulations (Cont'd)

2.3 Obligations of the Customer (Cont'd)

2.3.8 Claims and Demands for Damages (Cont'd)

(B) (Cont'd)

equipment connected to the Telephone Company's services provided under this tariff, including, without limitation, Workmen's Compensation claims, actions for infringement of copyright, and/or unauthorized use of program material, libel, and slander actions based on the content of communications transmitted over the customer's circuits, facilities, or equipment, and proceedings to recover taxes, fines, or penalties for failure of the customer to obtain or maintain in effect any necessary certificates, permits, licenses, or other authority to acquire or operate the services provided under this tariff; provided, however, the foregoing indemnification shall not apply to suits, claims, and demands to recover damages for damage to property, death, or personal injury unless such suits, claims, or demands are based on the tortious conduct of the customer, its officers, agents, or employees.

(C) The customer shall defend, indemnify, and save harmless the Telephone Company from and against any suits, claims, losses, or damages, including punitive damages, attorney fees, and court costs by the customer or third parties arising out of any act or omission of the customer in the course of using services provided under this tariff.

2.3.9 Coordination with Respect to Network Contingencies

The customer shall, in cooperation with the Telephone Company, coordinate in planning the actions to be taken to maintain maximum network capability following natural or man-made disasters which affect telecommunications services.

** New or Revised*

Continued

DATE ISSUED: July 31, 2002

EFFECTIVE DATE: September 18, 2002

Aloa J. Stevens
Director – State Government Affairs
Citizens Communications Company
4 Triad Center, Suite 200
Salt Lake City, Utah 84180

ACCESS SERVICE

2. General Regulations (Cont'd)

2.3 Obligations of the Customer (Cont'd)

2.3.10 Sectionalization of Trouble Reporting

The customer will be responsible for reporting troubles sectionalized to Telephone Company facilities and/or equipment. When trouble cannot be clearly sectionalized to the Telephone Company facilities and/or equipment, the Telephone Company will test cooperatively or independently to assist in trouble sectionalization.

(M)

(M)

(M) Item 2.4.1 relocated to Page 41.5.

(N)

** New or Revised*

Continued

DATE ISSUED: December 13, 2011

EFFECTIVE DATE: July 30, 2012

Kenneth Mason
Vice President – Government & Regulatory Affairs
Citizens Communications Company
180 S. Clinton Ave.
Rochester, NY 14646

ACCESS SERVICE

2. General Regulations (Cont'd)

2.3 Obligations of the Customer (Cont'd)

2.3.11 Identification and Rating of VoIP-PSTN Traffic ¹

(N)

(A) Scope

- (1) VoIP-PSTN Traffic is defined as traffic exchanged between the Telephone Company end user and the customer in time division multiplexing (“TDM”) format that originates and/or terminates in Internet protocol (“IP”) format. This section governs the identification of VoIP-PSTN Traffic that is required to be compensated at interstate access rates by the Federal Communications Commission in its Report and Order in WC Docket Nos. 10-90, etc., FCC Release No. 11-161 (Nov. 18, 2011) (“FCC Order”). Specifically, this section establishes the method of separating such traffic (referred to in this tariff as “Relevant VoIP-PSTN Traffic”) from the customer’s traditional intrastate access traffic, so that such Relevant VoIP-PSTN Traffic can be billed in accordance with the FCC Order.
- (2) This section will be applied to the billing of switched access charges to a customer that is a local exchange carrier only to the extent that the customer has also implemented billing of interstate access charges for Relevant VoIP-PSTN Traffic in accordance with the FCC Order.

¹ On April 25, 2012 the FCC released its Second Order on Reconsideration of the USF/ICC Transformation Order. Based on this Order, the tariff language in this section will also apply to originating access for VoIP-PSTN traffic for the period of December 29, 2011 through the effective date of the FCC's April 25th Order, which will occur 45 days after publication of the Order in the Federal Register.

(N)

Continued

DATE ISSUED: May 9, 2012

EFFECTIVE DATE: July 30, 2012

Kenneth Mason
Vice President – Government & Regulatory Affairs
Citizens Communications Company
180 S. Clinton Ave.
Rochester, NY 14646

ACCESS SERVICE

2. General Regulations (Cont'd)2.3 Obligations of the Customer (Cont'd)2.3.11 Identification and Rating of VoIP-PSTN Traffic

(N)

(B) Rating of VoIP-PSTN Traffic

The Relevant VoIP-PSTN Traffic identified in accordance with this tariff section will be billed at rates equal to the Telephone Company's applicable tariffed interstate switched access rates as specified in the Telephone Company's applicable Federal Access Tariff.

(C) Calculation and Application of Percent-VoIP-Usage Factor

The Telephone Company will determine the number of Relevant VoIP-PSTN Traffic minutes of use ("MOU") to which interstate rates will be applied under subsection (B), above, by applying a Percent VoIP Usage ("PVU") factor to the total intrastate access MOU exchanged with the Telephone Company from the customer. The PVU will be derived and applied as follows:

- (1) The customer will calculate and furnish to the Telephone Company a factor (the "PVU-C") representing the percentage of the total intrastate access MOU that the customer exchanges with the Telephone Company in the State, that is sent to the Telephone Company and that originated in IP format, or is received from the Telephone Company and terminated in IP format. This PVU-C shall be based on information such as traffic studies, actual call detail, or other relevant and verifiable information.

(N)

Continued

DATE ISSUED: May 9, 2012

EFFECTIVE DATE: July 30, 2012

Kenneth Mason
Vice President – Government & Regulatory Affairs
Citizens Communications Company
180 S. Clinton Ave.
Rochester, NY 14646

ACCESS SERVICE

2. General Regulations (Cont'd)2.3 Obligations of the Customer (Cont'd)2.3.11 Identification and Rating of VoIP-PSTN Traffic

(N)

(C) Calculation and Application of Percent-VoIP-Usage Factor (Cont'd)

- (2) The Telephone Company will, likewise, calculate a factor (the "PVU-T") representing the percentage of the Telephone Company's total intrastate access MOU in the State that the Telephone Company originates or terminates on its network in IP format. This PVU-T shall be based on information, such as the number of the Telephone Company's retail VoIP subscriptions in the state, traffic studies, actual call detail, or other relevant and verifiable information.
- (3) The Telephone Company will use the PVU-C and PVU-T factors to calculate a PVU factor that represents the percentage of total intrastate MOU exchanged between a Telephone Company end user and the customer that is originated or terminated in IP format, whether at the Telephone Company's end, at the customer's end, or at both ends. The PVU factor will be calculated as the sum of: (A) the PVU-C factor and (B) the PVU-T factor times (1.0 minus the PVU-C factor).
- (4) The Telephone Company will apply the PVU factor to the total intrastate access MOU exchanged with the customer to determine the number of Relevant VoIP-PSTN Traffic MOUs.
- (5) If the customer does not furnish the Telephone Company with a PVU-C pursuant to the preceding paragraph 1, the Telephone Company will utilize a PVU equal to the PVU-T.

(N)

Continued

DATE ISSUED: May 9, 2012

EFFECTIVE DATE: July 30, 2012

Kenneth Mason
Vice President – Government & Regulatory Affairs
Citizens Communications Company
180 S. Clinton Ave.
Rochester, NY 14646

ACCESS SERVICE

2. General Regulations (Cont'd)2.3 Obligations of the Customer (Cont'd)2.3.11 Identification and Rating of VoIP-PSTN Traffic

(N)

(D) Initial PVU Factor

If the PVU factor is not available and/or cannot be implemented in the Telephone Company's billing systems by February 15, 2012, once the factor is available and can be implemented the Telephone Company will adjust the customer's bills to reflect the PVU retroactively to February 15, 2012. This retroactive adjustment will be made to February 15, 2012, provided that the customer provides the factor to the Telephone Company no later than April 15, 2012; otherwise, it will set the initial PVU equal to zero, as specified in subsection (C)(1), preceding.

(E) PVU Factor Updates

The customer may update the PVU factor quarterly using the method set forth in subsection (C)(1), above. If the customer chooses to submit such updates, it shall forward to the Telephone Company, no later than 15 days after the first day of January, April, July and/or October of each year, a revised PVU factor based on data for the prior three months, ending the last day of December, March, June and September, respectively. The revised PVU factor will apply prospectively and serve as the basis for billing until superseded by a new PVU.

(F) PVU Factor Verification

Not more than four times in any year, the Telephone Company may ask the customer to verify the PVU factor furnished to the Telephone Company. The party so requested shall comply, and shall reasonably provide the records and other information used to determine the PVU factors.

(N)

Continued

DATE ISSUED: May 9, 2012

EFFECTIVE DATE: July 30, 2012

Kenneth Mason
Vice President – Government & Regulatory Affairs
Citizens Communications Company
180 S. Clinton Ave.
Rochester, NY 14646

ACCESS SERVICE

2. General Regulations (Cont'd)2.3 Obligations of the Customer (Cont'd)2.4 Payment Arrangements and Credit Allowances

(M)

2.4.1 Payment of Rates, Charges and Deposits(A) Deposits

The Telephone Company will, in order to safeguard its interests, only require a customer which has a proven history of late payments to the Telephone Company or does not have established credit, to make a deposit prior to or at any time after the provision of a service to the customer to be held by the Telephone Company as a guarantee of the payment of rates and charges. No such deposit will be required of a customer which is a successor of a company which has established credit and has no history of late payments to the Telephone Company. Such deposit may not exceed the actual or estimated rates and charges for the service for a two month period. The fact that a deposit has been made in no way relieves the customer from complying with the Telephone Company's regulations as to the prompt payment of bills. At such time as the provision of the service to the customer is terminated, the amount of the deposit will be credited to the customer's account and any credit balance which may remain will be refunded.

(M)

(N)

(M) Material relocated from Page 41.

** New or Revised**Continued*

DATE ISSUED: December 13, 2011

EFFECTIVE DATE: July 30, 2012

Kenneth Mason
Vice President – Government & Regulatory Affairs
Citizens Communications Company
180 S. Clinton Ave.
Rochester, NY 14646

ACCESS SERVICE

2. General Regulations (Cont'd)

2.4 Payment Arrangements and Credit Allowances (Cont'd)

2.4.1 Payment of Rates, Charges and Deposits (Cont'd)

(A) Deposits (Cont'd)

Such a deposit will be refunded or credited to the account when the customer has established credit or, in any event, after the customer has established a one-year prompt payment record at any time prior to the termination of the provision of the service to the customer. In case of a cash deposit, for the period the deposit is held by the Telephone Company, the customer will receive simple interest at a rate of 6%. Should a deposit be credited to the customer's account, as indicated above, no interest will accrue on the deposit from the date such deposit is credited to the customer's account.

(B) Payment of Rates and Charges

The Telephone Company shall bill on a current basis all charges incurred by and credits due to the customer under this tariff attributable to services established or discontinued during the preceding billing period. In addition, the Telephone Company shall bill in advance charges for all services to be provided during the ensuing billing period except for charges associated with service usage and for the Federal Government which will be billed in arrears. The bill day (i.e., the billing date of a bill for a customer for Access Service under this tariff), the period of service each bill covers and the payment date will be as follows:

** New or Revised*

Continued

DATE ISSUED: July 31, 2002

EFFECTIVE DATE: September 18, 2002

Aloa J. Stevens
Director – State Government Affairs
Citizens Communications Company
4 Triad Center, Suite 200
Salt Lake City, Utah 84180

ACCESS SERVICE

2. General Regulations (Cont'd)

2.4 Payment Arrangements and Credit Allowances (Cont'd)

2.4.1 Payment of Rates, Charges and Deposits (Cont'd)

(B) Payment of Rates and Charges (Cont'd)

- (1) For Presubscription Service, the Telephone Company will establish a bill day each month for each end user account. Any applicable Presubscription Charges, any known unbilled charges for prior periods and any known unbilled adjustments for prior periods for Presubscription Service will be applied to this bill. Such bills are due when rendered.

For End User Switched Access Service, Special Access Service, and Miscellaneous Service charges, the Telephone Company will establish a bill day each month for each customer account. The bill will cover nonusage sensitive service charges for the ensuing billing period for which the bill is rendered, any known unbilled nonusage sensitive charges for prior periods and unbilled usage charges for the period after the last bill day through the current bill day. Any known unbilled usage charges for prior periods and known unbilled adjustments will be applied to this bill. Payment for such bills is due as set forth in (2) following. If payment is not received by the payment date, as set forth in (2) following in immediately available funds, a late payment penalty will apply as set forth in (C) following.

- (2) All bills dated as set forth in (1) preceding for service, provided to the customer by the Telephone Company are due 31 days (payment date) after the bill date or by the next bill date (i.e., same date in the following month as the bill date), whichever is

** New or Revised*

Continued

DATE ISSUED: July 31, 2002

EFFECTIVE DATE: September 18, 2002

Aloa J. Stevens
Director – State Government Affairs
Citizens Communications Company
4 Triad Center, Suite 200
Salt Lake City, Utah 84180

ACCESS SERVICE

2. General Regulations (Cont'd)2.4 Payment Arrangements and Credit Allowances (Cont'd)2.4.1 Payment of Rates, Charges and Deposits (Cont'd)(B) Payment of Rates and Charges (Cont'd)

(2) (Cont'd)

the shortest interval, except as provided herein, and are payable in immediately available funds. If such payment date would cause payment to be due on a Saturday, Sunday, or Holiday (i.e., New Year's Day, Independence Day, Labor Day, Thanksgiving Day, Christmas Day, the first Tuesday in November and the day when Washington's Birthday, Memorial Day or Columbus Day is legally observed), payment for such bills will be due from the customer as follows:

If such payment date falls on Sunday or on a Holiday which is observed on a Monday, the payment date shall be the first non-Holiday day following such Sunday or Holiday. If such payment date falls on a Saturday or on a Holiday which is observed on Tuesday, Wednesday, Thursday, or Friday, the payment date shall be the last non-Holiday day preceding such Saturday or Holiday.

(C) Late Payment Penalty

If any portion of the payment is received by the Telephone Company after the payment date as set forth in (B)(2) preceding, or if any portion of the payment is received by the Telephone Company in funds which are not immediately available to the Telephone Company, then a late payment penalty shall be due to the Telephone Company in addition to the outstanding amount. The late

** New or Revised**Continued*

DATE ISSUED: July 31, 2002

EFFECTIVE DATE: September 18, 2002

Aloa J. Stevens
Director – State Government Affairs
Citizens Communications Company
4 Triad Center, Suite 200
Salt Lake City, Utah 84180

ACCESS SERVICE

2. General Regulations (Cont'd)2.4 Payment Arrangements and Credit Allowances (Cont'd)2.4.1 Payment of Rates, Charges and Deposits (Cont'd)(C) Late Payment Penalty (Cont'd)

payment penalty shall be the portion of the payment not received by the payment date times a late factor. The late factor shall be the lessor of:

- (1) the highest interest rate (in decimal value) which may be levied by law for commercial transactions, compounded daily for the number of days from the payment date to and including the date that the customer actually makes the payment to the Telephone Company, or
- (2) 0.000590 per day, compounded daily for the number of days from the payment date to and including the date that the customer actually makes the payment to the Telephone Company.

(D) Billing Disputes

In the event that a billing dispute occurs concerning any charges billed to the customer by the Telephone Company the following regulations will apply.

- (1) The date of the dispute shall be the date on which the customer furnishes the Telephone Company sufficient documentation to investigate the claim. Documentation must include, at the minimum, the account number under which the bill has been rendered, the date of the bill, the specific items on

* *New or Revised*

Continued

DATE ISSUED: July 31, 2002

EFFECTIVE DATE: September 18, 2002

Aloa J. Stevens
Director – State Government Affairs
Citizens Communications Company
4 Triad Center, Suite 200
Salt Lake City, Utah 84180

ACCESS SERVICE

2. General Regulations (Cont'd)2.4 Payment Arrangements and Credit Allowances (Cont'd)2.4.1 Payment of Rates, Charges and Deposits (Cont'd)(D) Billing Disputes (Cont'd)

(1) (Cont'd)

the bill being disputed, and, when possible, the applicable tariff section upon which the dispute is predicated.

(2) The date of resolution shall be the date on which the Telephone Company completes its investigation of the dispute, notifies the customer of the disposition and applies a credit for the amount of the dispute resolved in the customer's favor or late payment penalty as appropriate. The Telephone Company will work cooperatively with any customer to resolve billing disputes.

(3) If a billing dispute is resolved in favor of the Telephone Company, any payments withheld pending resolution of the dispute shall be subject to the late payment penalty as set forth in (C) preceding.

(4) If a billing dispute is resolved in favor of the customer and the customer pays the total billed amount on or before the payment date, the Telephone Company will refund any over-payment and will apply a credit for a disputed amount penalty as set forth in (a) and (b) following.

* *New or Revised*

Continued

DATE ISSUED: July 31, 2002

EFFECTIVE DATE: September 18, 2002

Aloa J. Stevens
Director – State Government Affairs
Citizens Communications Company
4 Triad Center, Suite 200
Salt Lake City, Utah 84180

ACCESS SERVICE

2. General Regulations (Cont'd)2.4 Payment Arrangements and Credit Allowances (Cont'd)2.4.1 Payment of Rates, Charges and Deposits (Cont'd)(D) Billing Disputes (Cont'd)

(4) (Cont'd)

- (a) If a customer disputes a bill within ninety (90) days of the bill date and pays the total billed amount on or before the payment date, and the billing dispute is resolved in favor of the customer, the customer will receive a credit for a disputed amount penalty from the Telephone Company for the period starting with the date of overpayment and ending on the date of resolution. The credit for a disputed amount penalty shall be an amount equal to the disputed amount resolved in the customer's favor times a penalty factor as set forth in (5) following.
- (b) If a customer disputes a bill after ninety (90) days from the bill date and pays the total billed amount on or before the payment date and the billing dispute is resolved in favor of the customer, the customer will receive a credit for a disputed amount penalty from the Telephone Company for the period starting with the date of claim and ending on the date of resolution. The credit for a disputed amount penalty shall be an amount equal to the disputed amount resolved in the customer's favor times a penalty factor as set forth in (5) following.

** New or Revised**Continued*

DATE ISSUED: July 31, 2002

EFFECTIVE DATE: September 18, 2002

Aloa J. Stevens
Director – State Government Affairs
Citizens Communications Company
4 Triad Center, Suite 200
Salt Lake City, Utah 84180

ACCESS SERVICE

2. General Regulations (Cont'd)

2.4 Payment Arrangements and Credit Allowances (Cont'd)

2.4.1 Payment of Rates, Charges and Deposits (Cont'd)

(D) Billing Disputes (Cont'd)

(5) The disputed amount penalty shall be an amount equal to the disputed amount resolved in the customer's favor times a penalty factor. The penalty factor shall be the lesser of:

- (a) the highest interest rate (in decimal value) which may be levied by law for commercial transactions, compounded daily for the number of days from the first date to and including the last date of the period involved, or
- (b) 0.000590 per day, compounded daily for the number of days from the first date to and including the last date of the period involved.

(E) Billing Adjustments and Rounding

Adjustments for the quantities of services established or discontinued in any billing period beyond the minimum period set forth for services in other sections of this tariff will be prorated to the number of days or major fraction of days based on a 30 day month. When a rate as set forth in this tariff is shown to more than two decimal places, the charges will be determined using the rate shown. The resulting amount will then be rounded to the nearest penny (i.e., rounded to two decimal places).

** New or Revised*

Continued

DATE ISSUED: July 31, 2002

EFFECTIVE DATE: September 18, 2002

Aloa J. Stevens
Director – State Government Affairs
Citizens Communications Company
4 Triad Center, Suite 200
Salt Lake City, Utah 84180

ACCESS SERVICE

2. General Regulations (Cont'd)2.4 Payment Arrangements and Credit Allowances (Cont'd)2.4.1 Payment of Rates, Charges and Deposits (Cont'd)(F) Provision of Access Service Billing and Bill Verification

- (1) The Telephone Company will, upon reasonable request and if available, furnish such detailed information as may be required for verification of any bill.
- (2) The customer will receive its monthly bills in a standard paper format, or, at the customer's option, on magnetic tape in standard industry format for those access services for which the Telephone Company is technically capable of providing magnetic tape billing. Additional copies of the customer's bill may be provided in standard paper format at the rates and charges set forth in (3) following. When the customer requests a paper copy of the customer's bill in addition to the customer bill provided on magnetic tape, the rate set forth in (3) following shall apply per page.
- (3)

Additional copies of the customer's monthly bill or service and features record in standard paper format, per page	<u>Rate</u>
	\$0.07

* *New or Revised**Continued*

DATE ISSUED: July 31, 2002

EFFECTIVE DATE: September 18, 2002

Aloa J. Stevens
Director – State Government Affairs
Citizens Communications Company
4 Triad Center, Suite 200
Salt Lake City, Utah 84180

ACCESS SERVICE

2. General Regulations (Cont'd)

2.4 Payment Arrangements and Credit Allowances (Cont'd)

2.4.2 Minimum Periods

The minimum period for which services are provided and for which rates and charges are applicable is one month except as otherwise specified.

The minimum period for which service is provided and for which rates and charges are applicable for a Specialized Service or Arrangement provided on an individual case basis as set forth in Section 12 following, is one month unless a different minimum period is established with the individual case filing.

When a service is discontinued prior to the expiration of the minimum period, charges are applicable, whether the service is used or not, as follows:

- (A) When a service with a one month minimum period is discontinued prior to the expiration of the minimum period, a one month charge will apply at the rate level in effect at the time service is discontinued.
- (B) When a service with a minimum period greater than one month is discontinued prior to the expiration of the minimum period, the applicable charge will be the lesser of (1) the Telephone Company's total nonrecoverable costs less the net salvage value for the discontinued service or (2) the total monthly charges, at the rate level in effect at the time service is discontinued, for the remainder of the minimum period.

2.4.3 Cancellation of an Order for Service

Provisions for the cancellation of an order for service are set forth in Section 5.3.2 following.

** New or Revised*

Continued

DATE ISSUED: July 31, 2002

EFFECTIVE DATE: September 18, 2002

Aloa J. Stevens
Director – State Government Affairs
Citizens Communications Company
4 Triad Center, Suite 200
Salt Lake City, Utah 84180

ACCESS SERVICE

2. General Regulations (Cont'd)

2.4 Payment Arrangements and Credit Allowances (Cont'd)

2.4.4 Credit Allowance for Service Interruptions

(A) General

A service is interrupted when it becomes unusable to the customer because of a failure of a facility component used to furnish service under this tariff or in the event that the protective controls applied by the Telephone Company result in the complete loss of service by the customer as set forth in Section 6 following. An interruption period starts when an inoperative service is reported to, or discovered by, the Telephone Company designated trouble reporting office and ends when the service is operative. The customer is responsible for sectionalizing trouble to the Telephone Company facilities and/or equipment as set forth in 2.3.10 preceding. (T)

In case of an interruption to any service, allowance for the period of interruption, if not due to the negligence of the customer, shall be calculated as set forth in (B) and (C) following. Interruptions for which no credit allowance applies are set forth in (D) following.

The credit allowance(s) for an interruption or for a series of interruptions shall not exceed the monthly rate and minimum monthly usage charge for the service interrupted in any one monthly billing period.

For purposes of this section of the tariff, "major fraction" is defined as that time period representing one-half or more of the incremental time period used to apply the credit allowance for those specific services listed in (B) following.

Continued

DATE ISSUED: May 9, 2012

EFFECTIVE DATE: July 1, 2012

Kenneth Mason
Vice President – Government & Regulatory Affairs
Citizens Communications Company
180 S. Clinton Ave.
Rochester, NY 14646

ACCESS SERVICE

2. General Regulations (Cont'd)

2.4 Payment Arrangements and Credit Allowances (Cont'd)

2.4.4 Credit Allowance for Service Interruptions (Cont'd)

(A) General (Cont'd)

Service interruptions for Specialized Service or Arrangements provided under the provisions of Section 12 following shall be administered in the same manner as those set forth in this section unless other regulations are specified with the individual case filing.

(B) Special Access Services

- (1) For Special Access Services other than Program Audio and Video Services, no credit shall be allowed for an interruption of less than 30 minutes. The customer shall be credited for an interruption of 30 minutes or more at the rate of 1/1440 of the monthly charges for the facility or service for each period of 30 minutes or major fraction thereof that the interruption continues.

The monthly charges used to determine the credit shall be as follows:

- (a) For two point services, the monthly charge subject to credit shall be the total of all the monthly rate element charges associated with the service (i.e., two circuit terminations, circuit mileage and optional features and functions).
- (b) For multipoint services, the monthly charge subject to credit shall be only the total of all the monthly rate element charges associated with

** New or Revised*

Continued

DATE ISSUED: July 31, 2002

EFFECTIVE DATE: September 18, 2002

Aloa J. Stevens
Director – State Government Affairs
Citizens Communications Company
4 Triad Center, Suite 200
Salt Lake City, Utah 84180

ACCESS SERVICE

2. General Regulations (Cont'd)2.4 Payment Arrangements and Credit Allowances (Cont'd)2.4.4 Credit Allowance for Service Interruptions (Cont'd)(B) Special Access Services (Cont'd)

(1) (Cont'd)

(b) (Cont'd)

that portion of the service that is inoperative (i.e., a circuit termination per customer premises, circuit mileage and optional features and functions).

- (c) For multiplexed services, the monthly charge subject to credit shall be the total of all the monthly rate element charges associated with that portion of the service that is inoperative. When the facility which is multiplexed or the multiplexer itself is inoperative, the monthly charge shall be the total of all the monthly rate element charges associated with the service (i.e., the circuit termination, circuit mileage and optional features and functions, including the multiplexer on the facility to the hub, and the circuit terminations, circuit mileages and optional features and functions on the individual services from the hub). When the service which rides a circuit of the multiplexed facility is inoperative, the monthly charge shall be the total of all the monthly rate element charges associated with that portion of the service from the Hub to a customer premises (i.e., circuit termination, circuit mileage and optional features and functions).

* *New or Revised*

Continued

DATE ISSUED: July 31, 2002

EFFECTIVE DATE: September 18, 2002

Aloa J. Stevens
Director – State Government Affairs
Citizens Communications Company
4 Triad Center, Suite 200
Salt Lake City, Utah 84180

ACCESS SERVICE

2. General Regulations (Cont'd)

2.4 Payment Arrangements and Credit Allowances (Cont'd)

2.4.4 Credit Allowance for Service Interruptions (Cont'd)

(B) Special Access Services (Cont'd)

- (2) For Program Audio and Video Special Access Services, no credit shall be allowed for an interruption of less than 30 seconds. The customer shall be credited for an interruption of 30 seconds or more as follows:
- (a) For two-point services, when monthly rates are applicable, the credit shall be at the rate of 1/8640 of the monthly charges for the service for each period of 5 minutes or major fraction thereof that the interruption continues.
 - (b) For two-point services, when daily rates are applicable, the credit shall be at the rate of 1/288 of the daily charges for the service for each period of 5 minutes or major fraction thereof that the interruption continues.
 - (c) For multipoint services, when monthly rates are applicable, the credit shall be at the rate of 1/8640 of the monthly charges for each circuit termination, circuit mileage and optional features and functions that is inoperative for each period of 5 minutes or major fraction thereof that the interruption continues.
 - (d) For multipoint services, when daily rates are applicable, the credit shall be at the daily rate of 1/288 of the daily charges for each circuit termination, circuit mileage and optional features and functions that is inoperative for each period of 5 minutes or major fraction thereof that the interruption continues.

** New or Revised*

Continued

DATE ISSUED: July 31, 2002

EFFECTIVE DATE: September 18, 2002

Aloa J. Stevens
Director – State Government Affairs
Citizens Communications Company
4 Triad Center, Suite 200
Salt Lake City, Utah 84180

ACCESS SERVICE

2. General Regulations (Cont'd)

2.4 Payment Arrangements and Credit Allowances (Cont'd)

2.4.4 Credit Allowance for Service Interruptions (Cont'd)

(B) Special Access Services (Cont'd)

(2) (Cont'd)

(e) For multipoint services, the credit for the monthly or daily charges includes the charges for the distribution amplifier only when the distribution amplifier is inoperative.

(f) When two or more interruptions occur during a period of 5 consecutive minutes, such multiple interruptions shall be considered as one interruption.

(3) For certain Special Access services (Wideband Digital, WD1-3; Digital Data Access, DA1-4; and High Capacity, HC1), any period during which the error performance is below that specified for the service will be considered as an interruption.

(C) Switched Access Service

For Switched Access Service, no credit shall be allowed for an interruption of less than 24 hours. The customer shall be credited for an interruption of 24 hours or more at the rate of 1/30 of any applicable monthly rate, assumed usage, or minimum monthly usage charge for each period of 24 hours or major fraction thereof that the interruption continues.

** New or Revised*

Continued

DATE ISSUED: July 31, 2002

EFFECTIVE DATE: September 18, 2002

Aloa J. Stevens
Director – State Government Affairs
Citizens Communications Company
4 Triad Center, Suite 200
Salt Lake City, Utah 84180

ACCESS SERVICE

2. General Regulations (Cont'd)

2.4 Payment Arrangements and Credit Allowances (Cont'd)

2.4.4 Credit Allowance for Service Interruptions (Cont'd)

(D) When a Credit Allowance Does Not Apply

No credit allowance will be made for:

- (1) Interruptions caused by the negligence of the customer.
- (2) Interruptions of a service due to the failure of equipment or systems provided by the customer or others.
- (3) Interruptions of service during any period in which the Telephone Company is not afforded access to the premises where the service is terminated.
- (4) Interruptions of service when the customer has released that service to the Telephone Company for maintenance purposes, to make rearrangements, or for the implementation of an order for a change in the service during the time that was negotiated with the customer prior to the release of that service. Thereafter, a credit allowance as set forth in (B) preceding applies.
- (5) Interruptions of a service which continue because of the failure of the customer to authorize replacement of any element of special construction, as set forth in Section 14. The period for which no credit allowance is made begins on the seventh day after the customer receives the Telephone Company's written notification of the need for such replacement and ends on the day after receipt by the Telephone Company of the customer's written authorization for such replacement.

** New or Revised*

Continued

DATE ISSUED: July 31, 2002

EFFECTIVE DATE: September 18, 2002

Aloa J. Stevens
Director – State Government Affairs
Citizens Communications Company
4 Triad Center, Suite 200
Salt Lake City, Utah 84180

ACCESS SERVICE

2. General Regulations (Cont'd)

2.4 Payment Arrangements and Credit Allowances (Cont'd)

2.4.4 Credit Allowance for Service Interruptions (Cont'd)

(D) When a Credit Allowance Does Not Apply (Cont'd)

- (6) Periods when the customer elects not to release the service of testing and/or repair and continues to use it on an impaired basis.
- (7) An interruption or a group of interruptions, resulting from a common cause, for amounts less than one dollar.

(E) Use of an Alternative Service Provided by the Telephone Company

Should the customer elect to use an alternative service provided by the Telephone Company during the period that a service is interrupted, the customer must pay the tariffed rates and charges for the alternative service used.

(F) Temporary Surrender of a Service

In certain instances, the customer may be requested by the Telephone Company to surrender a service for purposes other than maintenance, testing, or activity relating to a service order. If the customer consents, a credit allowance will be granted. The credit allowance will be 1/1440 of the monthly rate for each period of 30 minutes or fraction thereof that the service is surrendered. In no case will the credit allowance exceed the monthly rate for the service surrendered in any one monthly billing period.

** New or Revised*

Continued

DATE ISSUED: July 31, 2002

EFFECTIVE DATE: September 18, 2002

Aloa J. Stevens
Director – State Government Affairs
Citizens Communications Company
4 Triad Center, Suite 200
Salt Lake City, Utah 84180

ACCESS SERVICE

2. General Regulations (Cont'd)

2.4 Payment Arrangements and Credit Allowances (Cont'd)

2.4.5 Re-establishment of Service Following Fire, Flood or Other Occurrences

(A) Nonrecurring Charges Do Not Apply

Charges do not apply for the re-establishment of service following a fire, flood, or other occurrence attributed to an Act of God provided that:

- (1) The service is of the same type as was provided prior to the fire, flood or other occurrence.
- (2) The service is for the same customer.
- (3) The service is at the same location on the same premises.
- (4) The re-establishment of service begins within 60 days after Telephone Company service is available. (The 60 day period may be extended a reasonable period if the renovation of the original location on the premises affected is not practical within the allotted time period).

(B) Nonrecurring Charges Apply

Nonrecurring charges apply for establishing service at a different location on the same premises or at a different premises pending re-establishment of service at the original location.

2.4.6 Title or Ownership Rights

The payment of rates and charges by customers for the services offered under the provisions of this tariff does not assign, confer, or transfer title or ownership rights to proposals or facilities developed or utilized, respectively, by the Telephone Company in the provision of such services.

** New or Revised*

Continued

DATE ISSUED: July 31, 2002

EFFECTIVE DATE: September 18, 2002

Aloa J. Stevens
Director – State Government Affairs
Citizens Communications Company
4 Triad Center, Suite 200
Salt Lake City, Utah 84180

ACCESS SERVICE

2. General Regulations (Cont'd)

2.4 Payment Arrangements and Credit Allowances (Cont'd)

2.4.7 Access Services Provided by More Than One Telephone Company

The Telephone Company will perform the rating and billing of Access Services under this tariff where more than one Telephone Company is involved in the provision of Access Service as set forth in (A), (B), or (C) following. The Single Company Billing arrangement as set forth in (A) following will be used for FGA and FGB Switched Access Services except where interconnection arrangements between the telephone companies involved permit the use of the Multiple Company Billing arrangement as set forth in (B) following. The Telephone Company will notify the customer of the billing arrangement when the customer orders FGA or FGB service. The Multiple Company Billing arrangements, as set forth in (B) following, will be used for all FGC, FGD, and 800 Access, Switched Access Services and Special Access Services.

(A) Single Company Billing

The Telephone Company receiving the order from the customer as specified in Section 5.2(A) following will arrange to provide the service, determine the applicable charges, and bill the customer for the entire service in accordance with its Access Services tariff.

(B) Multiple Company Billing

- (1) For access services subject to Multiple Company Billing, the customer will be billed according to one of the following methods:

** New or Revised*

Continued

DATE ISSUED: July 31, 2002

EFFECTIVE DATE: September 18, 2002

Aloa J. Stevens
Director – State Government Affairs
Citizens Communications Company
4 Triad Center, Suite 200
Salt Lake City, Utah 84180

ACCESS SERVICE

2. General Regulations (Cont'd)

2.4 Payment Arrangements and Credit Allowances (Cont'd)

2.4.7 Access Services Provided by More Than One Telephone Company (Cont'd)

(B) Multiple Company Billing (Cont'd)

(1) (Cont'd)

Single Bill -

The customer will receive a single bill for all access services provided by multiple Telephone Companies. The single bill will include all rate elements applicable to the access service(s) provided under one billing account.

Multiple Bill -

The customer will receive a bill from each Telephone Company providing the access service(s). Multiple bills will include all charges applicable to the individual portion of the access service(s) provided by each Telephone Company.

The choice of billing method shall be determined by the Telephone Companies involved. The Telephone Company will notify the customer which method applies when the customer orders access service and will provide the customer thirty days' notice in the event that the billing method is changed.

** New or Revised*

Continued

DATE ISSUED: July 31, 2002

EFFECTIVE DATE: September 18, 2002

Aloa J. Stevens
Director – State Government Affairs
Citizens Communications Company
4 Triad Center, Suite 200
Salt Lake City, Utah 84180

ACCESS SERVICE

2. General Regulations (Cont'd)2.4 Payment Arrangements and Credit Allowances (Cont'd)2.4.7 Access Services Provided by More Than One Telephone Company (Cont'd)(B) Multiple Company Billing (Cont'd)

- (2) For Switched Access Services, the Telephone Company will determine the applicable charges as follows:
 - (a) Determine the distance in airline miles using the V&H information set forth in Section 15 of this tariff between the Telephone Company's end office switch and the customer's serving wire center.
 - (b) The airline distance in miles developed in (a) preceding will be multiplied by the Local Transport Mileage rate times the number of access minutes of use times the billing percentage to determine the appropriate Local Transport Mileage charges. The billing percentage is that portion of local transport to be billed by each company and is mutually agreed upon by the Telephone Companies involved in providing Access Services to the customer. Billing percentages are listed in Section 15 of this tariff.
 - (c) The total Local Transport charge shall be the Local Transport Mileage charge as determined in (b) preceding plus the Local Transport Circuit Connection rate times the number of access minutes of use. The Circuit Connection rate applies only at the Telephone Company end office.

** New or Revised**Continued*

DATE ISSUED: July 31, 2002

EFFECTIVE DATE: September 18, 2002

Aloa J. Stevens
Director – State Government Affairs
Citizens Communications Company
4 Triad Center, Suite 200
Salt Lake City, Utah 84180

ACCESS SERVICE

2. General Regulations (Cont'd)2.4 Payment Arrangements and Credit Allowances (Cont'd)2.4.7 Access Services Provided by More Than One Telephone Company (Cont'd)(B) Multiple Company Billing (Cont'd)

(2) (Cont'd)

(d) All other appropriate recurring and nonrecurring charges in each Telephone Company's access tariff are applicable.

(3) For Special Access Services, the Telephone Company will determine the applicable charges as follows:

(a) Determine the distance in airline miles using the V&H information set forth in Section 15 of this tariff between the locations involved; i.e., the serving wire centers associated with two customer designated premises, a serving wire center associated with a customer designated premise and a Telephone Company hub, or two Telephone Company hubs.

(b) The airline distance in miles developed in (a) preceding will be multiplied by the Circuit Mileage - Per Mile rate element times the billing percentage to determine the appropriate Circuit Mileage-Per Mile charges. The billing percentage is that portion of circuit mileage to be billed by each company and is mutually agreed upon by the Telephone Companies involved in providing Access Services to the customer. Billing percentages are listed in Section 15 of this tariff.

* *New or Revised*

Continued

DATE ISSUED: July 31, 2002

EFFECTIVE DATE: September 18, 2002

Aloa J. Stevens
Director – State Government Affairs
Citizens Communications Company
4 Triad Center, Suite 200
Salt Lake City, Utah 84180

ACCESS SERVICE

2. General Regulations (Cont'd)2.4 Payment Arrangements and Credit Allowances (Cont'd)2.4.7 Access Services Provided by More Than One Telephone Company (Cont'd)(B) Multiple Company Billing (Cont'd)

(3) (Cont'd)

- (c) The total Circuit Mileage charges shall be the Circuit Mileage Per-Mile charge determined in (b) preceding plus the Circuit Mileage-Fixed charge.
- (d) All other appropriate recurring and nonrecurring charges in each Telephone Company's access tariff are applicable.

(C) EAS and Access Tandem Arrangements

Where a customer utilizes FGA and/or FGB Switched Access Services to originate or terminate calls within an Extended Area Service (EAS) calling area or access tandem network provided by more than one telephone company, the Telephone Company may apply additional Switched Access Service charges as set forth in (1) and (2) following, provided the following criteria are met:

- The telephone companies involved are not the same Telephone Company and do not provide service under the same Access Service tariff,
- The telephone companies do not have a revenue sharing arrangement where one telephone company bills the total cost of access which includes the other telephone company's cost of access,

* *New or Revised**Continued*

DATE ISSUED: July 31, 2002

EFFECTIVE DATE: September 18, 2002

Aloa J. Stevens
Director – State Government Affairs
Citizens Communications Company
4 Triad Center, Suite 200
Salt Lake City, Utah 84180

 ACCESS SERVICE

2. General Regulations (Cont'd)2.4 Payment Arrangements and Credit Allowances (Cont'd)2.4.7 Access Services Provided by More Than One Telephone Company (Cont'd)(C) EAS and Access Tandem Arrangements (Cont'd)

- The telephone companies involved do not bill Switched Access charges in accordance with the Multiple Company Billing Arrangement for subtending end offices of an access tandem as set forth in (B) preceding.

(1) For FGA usage which originates or terminates at a Telephone Company end office within an EAS calling area where the first point of switching (dial tone office) is provided by a different telephone company, the Telephone Company will apply Carrier Common Line rates as set forth in Section 16.1, Local Transport Mileage and Circuit Connection rates to originating access minutes, and End Office rates to originating and terminating access minutes as set forth in Section 6 following. The mileage used to determine the Local Transport Mileage charges will be based on the airline distance between the end office where the call originates and the dial tone office where the FGA service is provided. Such Switched Access charges will be in addition to those charges assessed by the telephone company in whose exchange the first point of switching (dial tone office) is located. Such usage will be determined as set forth in (3) following. (T)

(2) For FGB usage which originates or terminates at a Telephone Company end office which subtends an access tandem provided a different telephone company where the FGB service is provided, the Telephone Company will apply Carrier Common Line rates as set forth in Section 16.1, End Office and

Continued

DATE ISSUED: May 9, 2012

EFFECTIVE DATE: July 1, 2012

Kenneth Mason
 Vice President – Government & Regulatory Affairs
 Citizens Communications Company
 180 S. Clinton Ave.
 Rochester, NY 14646

ACCESS SERVICE

2. General Regulations (Cont'd)2.4 Payment Arrangements and Credit Allowances (Cont'd)2.4.7 Access Services Provided by More Than One Telephone Company (Cont'd)(C) EAS and Access Tandem Arrangements (Cont'd)

(2) (Cont'd)

Local Transport Circuit Connection Rates as set forth in Section 6 following for all originating and terminating access minutes routed via the access tandem. Such usage will be determined as set forth in (3) following.

(3) FGA or FGB usage originating or terminating at Telephone Company end offices in EAS or access tandem arrangements shall be determined as follows:

- (a) Where end office specific usage data are available, such data will be used to determine the charges.
- (b) Where end office specific usage data are not available, the total originating and/or terminating usage will be the measured usage or assumed usage at the first point of switching (i.e., dial tone office for FGA or access tandem for FGB). Originating and/or terminating usage will be determined based upon the ratios of the total number of subscriber lines in the Telephone Company exchange to the total number of subscriber lines in the EAS calling area or access tandem network. These ratios will be applied to the total number of originating

** New or Revised**Continued*

DATE ISSUED: July 31, 2002

EFFECTIVE DATE: September 18, 2002

Aloa J. Stevens
Director – State Government Affairs
Citizens Communications Company
4 Triad Center, Suite 200
Salt Lake City, Utah 84180

ACCESS SERVICE

2. General Regulations (Cont'd)

2.4 Payment Arrangements and Credit Allowances (Cont'd)

2.4.7 Access Services Provided by More Than One Telephone Company (Cont'd)

(C) EAS and Access Tandem Arrangements (Cont'd)

(3) (Cont'd)

(b) (Cont'd)

and/or terminating access minutes to determine the access minutes for the Telephone Company exchange.

(4) The ratio used to calculate the access minutes as set forth in (3) preceding will be determined by the telephone company and provided to the customer upon request.

2.5 Connections

Equipment and Systems (i.e., terminal equipment, multiline terminating systems, and communications systems) may be connected with Switched and Special Access Service furnished by the Telephone Company where such connection is made in accordance with the provisions specified in Technical Reference Publication AS No. 1 and in 2.1 preceding.

** New or Revised*

Continued

DATE ISSUED: July 31, 2002

EFFECTIVE DATE: September 18, 2002

Aloa J. Stevens
Director – State Government Affairs
Citizens Communications Company
4 Triad Center, Suite 200
Salt Lake City, Utah 84180

ACCESS SERVICE

2. General Regulations (Cont'd)2.6 Definitions

Certain terms used herein are defined as follows:

Access Area

The term "Access Area" denotes a specific calling area serviced by one or more central offices associated with the various Switched Access Services offered under this tariff. The size and configuration of the access area a customer obtains is dependent upon the Feature Group type and the specific characteristics of the Central Office or Access Tandem Network in which the connection is made.

Access Code

The term "Access Code" denotes a uniform five or seven digit code assigned by the Telephone Company to an individual customer. The five digit code has the form 10XXX, and the seven digit code has the form 950-1/0XXX.

Access Minutes

The term "Access Minutes" denotes that usage of exchange facilities in intrastate or foreign service for the purpose of calculating chargeable usage. On the originating end of an intrastate or foreign call, usage is measured from the time the originating end user's call is delivered by the Telephone Company to and acknowledged as received by the customer's facilities connected with the originating exchange. On the terminating end of an intrastate or foreign call, usage is measured from the time the call is received by the end user in the terminating exchange. Timing of usage at both originating and terminating ends of an intrastate or foreign call shall terminate when the calling or called party disconnects, whichever event is recognized first in the originating and terminating exchanges, as applicable.

* *New or Revised*

Continued

DATE ISSUED: July 31, 2002

EFFECTIVE DATE: September 18, 2002

Aloa J. Stevens
Director – State Government Affairs
Citizens Communications Company
4 Triad Center, Suite 200
Salt Lake City, Utah 84180

ACCESS SERVICE

2. General Regulations (Cont'd)

2.6 Definitions (Cont'd)

Access Tandem

The term "Access Tandem" denotes a Telephone Company switching system that provides a concentration and distribution function for originating and/or terminating traffic between end offices and a customer's premises.

Access Tandem Network

The term "Access Tandem Network" denotes the network of trunk groups that provide a concentration and distribution function for originating and/or terminating Switched Access traffic between a single access tandem and Telephone Company subtending end offices.

Answer/Disconnect Supervision

The term "Answer/Disconnect Supervision" denotes the transmission of the switch trunk equipment supervisory signal (off-hook or on-hook) to the customer's point of termination as an indication that the called party has answered or disconnected.

Answer Message

The term "Answer Message" denotes an SS7 message sent in the backward direction to indicate that the call has been answered.

Attenuation Distortion

The term "Attenuation Distortion" denotes the difference in loss at specified frequencies relative to the loss at 1004 Hz, unless otherwise specified.

Balance (100 Type) Test Line

The term "Balance (100 Type) Test Line" denotes an arrangement in an end office which provides for balance and noise testing.

** New or Revised*

Continued

DATE ISSUED: July 31, 2002

EFFECTIVE DATE: September 18, 2002

Aloa J. Stevens
Director – State Government Affairs
Citizens Communications Company
4 Triad Center, Suite 200
Salt Lake City, Utah 84180

ACCESS SERVICE

2. General Regulations (Cont'd)

2.6 Definitions (Cont'd)

Bit

The term "Bit" denotes the smallest unit of information in the binary system of notation.

Business Day

The term "Business Day" denotes the times of day that a company is open for business. Generally, in the business community, these are 8:00 or 9:00 A.M. to 5:00 or 6:00 P.M., respectively, with an hour for lunch, Monday through Friday, resulting in a standard forty (40) hour work week. However, Business Day hours for the Telephone Company may vary based on company policy, union contract, and location. To determine such hours for an individual company, or company location, contact the issuing officer at the address shown on Title Page 1.

Busy Hour Minutes of Capacity (BHMC)

The term "Busy Hour Minutes of Capacity (BHMC)" denotes the customer specified maximum amount of Switched Access Service access minutes the customer expects to be handled in an end office switch during any hour in an 8:00 A.M. to 11:00 P.M. period for the Switched Access Arrangement ordered. This customer furnished BHMC quantity is the input data the Telephone Company uses to determine the number of transmission paths or facility requirements for the Switched Access Arrangement ordered.

Call

The term "Call" denotes a customer attempt for which the complete address code (e.g., 0-, 911, or 10 digits) is provided to the serving dial tone office.

** New or Revised*

Continued

DATE ISSUED: July 31, 2002

EFFECTIVE DATE: September 18, 2002

Aloa J. Stevens
Director – State Government Affairs
Citizens Communications Company
4 Triad Center, Suite 200
Salt Lake City, Utah 84180

ACCESS SERVICE

2. General Regulations (Cont'd)

2.6 Definitions (Cont'd)

Carrier or Common Carrier

See Interexchange Carrier.

CCS

The term "CCS" denotes a hundred call seconds, which is a standard unit of traffic load that is equal to 100 seconds of usage or capacity of a group of servers (e.g., trunks).

Central Office

The term "Central Office" denotes a local Telephone Company switching system where Telephone Exchange Service customer station loops are terminated for purposes of interconnection to each other and to trunks.

Central Office Prefix

The term "Central Office Prefix" denotes the first three digits (NXX) of the seven digit telephone number assigned to a customer's Telephone Exchange Service when dialed on a local basis.

Centralized Automatic Reporting on Trunks Testing

The term "Centralized Automatic Reporting on Trunks Testing" denotes a type of testing which includes the capacity for measuring operational and transmission parameters.

Circuit(s)

The term "Circuit(s)" denotes an electrical or photonic, in the case of fiber optic-based transmission systems, communications path between two or more points of termination.

** New or Revised*

Continued

DATE ISSUED: July 31, 2002

EFFECTIVE DATE: September 18, 2002

Aloa J. Stevens
Director – State Government Affairs
Citizens Communications Company
4 Triad Center, Suite 200
Salt Lake City, Utah 84180

ACCESS SERVICE

2. General Regulations (Cont'd)

2.6 Definitions (Cont'd)

Channel Service Unit

The term "Channel Service Unit" denotes customer premises equipment which performs one or more of the following functions: termination of a digital facility, regeneration of digital signals, detection and/or correction of signal format error, and remote loop back.

Channelize

The term "Channelize" denotes the process of multiplexing-demultiplexing wider bandwidth or higher speed channels into narrow bandwidth or lower speed channels.

C-Message Noise

The term "C-Message Noise" denotes the frequency weighted average noise within an idle voice channel. The frequency weighting, called C-message, is used to simulate the frequency characteristic of the 500-type telephone set and the hearing of the average subscriber.

C-Notched Noise

The term "C-Notched Noise" denotes the C-message frequency weighted noise on a voice channel with a holding tone, which is removed at the measuring end through a notch (very narrow band) filter.

Coin Station

The term "Coin Station" denotes a location where Telephone Company equipment is provided in a public or semipublic place where Telephone Company customers can originate telephone communications and pay the applicable charges by inserting coins into the equipment.

** New or Revised*

Continued

DATE ISSUED: July 31, 2002

EFFECTIVE DATE: September 18, 2002

Aloa J. Stevens
Director – State Government Affairs
Citizens Communications Company
4 Triad Center, Suite 200
Salt Lake City, Utah 84180

ACCESS SERVICE

2. General Regulations (Cont'd)

2.6 Definitions (Cont'd)

Common Channel Signaling System 7 Network (CCS7)

The term "Common Channel Signaling System 7 Network (CCS7)" denotes a dedicated out-of-band signaling network, which utilizes Signaling System 7 (SS7) protocol to provide call handling and data base access services.

Common Line

The term "Common Line" denotes a line, trunk, pay telephone line, or other facility provided under the general and/or local exchange service tariffs of the Telephone Company, terminated on a central office switch. A common line-residence is a line or trunk provided under the residence regulations of the general and/or local exchange service tariffs. A common line-business is a line provided under the business regulations of the general and/or local exchange service tariffs.

Communications System

The term "Communications System" denotes channels and other facilities, which are capable of communications between terminal equipment provided by other than the Telephone Company.

Customer(s)

The term "Customer(s)" denotes any individual, partnership, association, joint-stock company, trust, corporation, or governmental entity or other entity which subscribes to the services offered under this tariff, including both Interexchange Carriers (ICs) and End Users.

Customer Designated Premises (CDP)

A CDP may be designated by the customer for Switched Access, Special Access, or both in combination. When a customer orders Special Access to connect to a Telephone Company Switch, that switch is a CDP where the Special Access Service Terminates. Customer transmission facilities and equipment terminated in Telephone Company central offices under EIS arrangements, as defined in Frontier Telephone Companies Tariff FCC No. 1, Section 16 are not considered a CDP. However, Telephone Company Special Access Services may be interconnected to such customer equipment using a Cross Connect arrangement.

(L) Material relocated to Page 73.

(N)
|
(N)

Continued

ACCESS SERVICE

2. General Regulations (Cont'd)

2.6 Definitions (Cont'd)

Data Transmission (107 Type) Test Line

The term "Data Transmissions (107 Type) Test Line" denotes an arrangement, which provides for a connection to a signal source, which provides test signals for one-way testing of data and voice transmission parameters.

(L)
|
(L)

Decibel

The term "Decibel" denotes a unit used to express relative differences in power, usually between acoustic or electric signals, equal to ten (10) times the common logarithm of the ratio of two signal powers.

Decibel Reference Noise C-Message Weighting

The term "Decibel Reference Noise C-Message Weighting" denotes noise power measurements with C-Message Weighting in decibels relative to a reference 1000 Hz tone of 90 dB below 1 milliwatt.

Decibel Reference Noise C-Message Referenced to 0

The term "Decibel Reference Noise C-Message Referenced to 0" denotes noise power in "Decibel Reference Noise C-Message Weighting" referred to or measured at a zero transmission level point.

Dual Tone Multifrequency Address Signaling

The term "Dual Tone Multifrequency Address Signaling" denotes a type of signaling that is an optional feature of Switched Access Feature group A. It may be utilized when Feature Group A is being used in the terminating direction (from the point of termination with the customer to the local exchange end office). An office arranged for Dual Tone Multifrequency Signaling would expect to receive address signals from the customer in the form of Dual Tone Multifrequency signals.

Echo Control

The term "Echo Control" denotes the control of reflected signals in a telephone transmission path.

(L) Material relocated from Page 72.

(N)

Continued

ACCESS SERVICE

2. General Regulations (Cont'd)

2.6 Definitions (Cont'd)

Echo Path Loss

The term "Echo Path Loss" denotes the measure of reflected signal at a four-wire point of interface without regard to the send and receive Transmission Level Point.

Echo Return Loss

The term "Echo Return Loss" denotes a frequency weighted measure of return loss over the middle of the voiceband (approximately 500 to 2500 Hz), where talker echo is most annoying.

Effective Two-Wire

The term "Effective Two-Wire" denotes a condition which permits the simultaneous transmission in both directions over a channel, but it is not possible to insure independent information transmission in both directions. Effective two-wire channels may be terminated with two-wire or four-wire interfaces.

Effective Four-Wire

The term "Effective Four-Wire" denotes a condition which permits the simultaneous independent transmission of information in both directions over a channel. The method of implementing effective four-wire transmission is at the discretion of the Telephone Company (physical, time domain, frequency-domain separation, or echo cancellation techniques). Effective four-wire channels may be terminated with a two-wire interface at the customer's premises. However, when terminated two-wire, simultaneous independent transmission cannot be supported because the two wire interface combines the transmission paths into a single path.

** New or Revised*

Continued

DATE ISSUED: July 31, 2002

EFFECTIVE DATE: September 18, 2002

Aloa J. Stevens
Director – State Government Affairs
Citizens Communications Company
4 Triad Center, Suite 200
Salt Lake City, Utah 84180

ACCESS SERVICE

2. General Regulations (Cont'd)2.6 Definitions (Cont'd)End Office Switch

The term "End Office Switch" denotes a local Telephone Company switching system where Telephone Exchange Service customer station loops are terminated for purposes of interconnection to each other and to trunks. Included may be Remote Switching Modules and Remote Switching Systems served by a host office in a different wire center.

End User

The term "End User" denotes any customer of intrastate or foreign telecommunications service that is not a carrier, except that a carrier shall be deemed to be an "end user" to the extent that such carrier uses a telecommunications service for administrative purposes, without making such service available to others, directly or indirectly.

Entry Switch

See First Point of Switching.

Envelope Delay Distortion

The term "Envelope Delay Distortion" denotes a measure of the linearity of the phase versus frequency of a channel.

Equal Level Echo Path Loss

The term "Equal Level Echo Path Loss" (ELEPL) denotes the measure of Echo Path Loss (EPL) at a four-wire interface which is corrected by the difference between the send and receive Transmission Level Point (TLP). [ELEPL = TLP (send) + TLP (receive)].

* *New or Revised*

Continued

DATE ISSUED: July 31, 2002

EFFECTIVE DATE: September 18, 2002

Aloa J. Stevens
Director – State Government Affairs
Citizens Communications Company
4 Triad Center, Suite 200
Salt Lake City, Utah 84180

ACCESS SERVICE

2. General Regulations (Cont'd)

2.6 Definitions (Cont'd)

Exchange

The term "Exchange" denotes a unit generally smaller than a Local Access and Transport Area, established by the Telephone Company for the administration of communications service in a specified area which usually embraces a city, town or village and its environs. It consists of one or more central offices together with the associated facilities used in furnishing communications service within the area. One or more designated exchanges comprise a given Local Access and Transport Area.

Exit Message

The term "Exit Message" denotes an SS7 message sent to an end office by the Telephone Company tandem switch to mark the Carrier Connect Time when the Telephone Company's tandem switch sends an Initial Address Message to an Interexchange Customer.

Expected Measured Loss

The term "Expected Measured Loss" denotes a calculated loss which specifies the end-to-end 1004-Hz loss on a terminated test connection between two readily accessible manual or remote test points. It is the sum of the inserted connection loss and test access loss including any test pads.

Extended Area Service

The term "Extended Area Service" denotes a telephone exchange service in which a customer in one exchange can call a local number in another exchange that is part of the extended area without paying a toll charge.

** New or Revised*

Continued

DATE ISSUED: July 31, 2002

EFFECTIVE DATE: September 18, 2002

Aloa J. Stevens
Director – State Government Affairs
Citizens Communications Company
4 Triad Center, Suite 200
Salt Lake City, Utah 84180

ACCESS SERVICE

2. General Regulations (Cont'd)

2.6 Definitions (Cont'd)

Field Identifier

The term "Field Identifier" denotes two to four characters that are used on service orders to convey specific instructions. Field Identifiers may or may not have associated data. Selected Field Identifiers are used in Telephone Company billing systems to generate nonrecurring charges.

First Come - First Served

The term "First Come - First Served" denotes a procedure followed by the Telephone Company to process fully completed Access Orders according to the sequence in which they are received.

First Point of Switching

The term "First Point of Switching" denotes the first Telephone Company location at which switching occurs on the terminating path of a call proceeding from the customer premises to the terminating end office and, at the same time, the last Telephone Company location at which switching occurs on the originating path of a call proceeding from the originating end office to the customer premises.

Frequency Shift

The term "Frequency Shift" denotes the change in the frequency of a tone as it is transmitted over a channel.

Grandfathered

The term "Grandfathered" denotes Terminal Equipment, Multiline Terminating Systems and Protective Circuitry directly connected to the facilities utilized to provide services under the provisions of this tariff, and which are considered grandfathered under Part 68 of the F.C.C.'s Rules and Regulations.

** New or Revised*

Continued

DATE ISSUED: July 31, 2002

EFFECTIVE DATE: September 18, 2002

Aloa J. Stevens
Director – State Government Affairs
Citizens Communications Company
4 Triad Center, Suite 200
Salt Lake City, Utah 84180

ACCESS SERVICE

2. General Regulations (Cont'd)

2.6 Definitions (Cont'd)

Host Office

The term "Host Office" denotes an electronic switching system which provides call processing capabilities for one or more Remote Switching Modules or Remote Switching Systems.

Immediately Available Funds

The term "Immediately Available Funds" denotes a corporate or personal check drawn on a bank account and funds which are available for use by the receiving party on the same day on which they are received and include U.S. Federal Reserve bank wire transfers, U.S. Federal Reserve notes (paper cash), U.S. coins, U.S. Postal Money Orders, and New York Certificates of Deposit.

Impedance Balance

The term "Impedance Balance" denotes the method of expressing Echo Return Loss and Singing Return Loss at a four-wire interface whereby the gains and/or loss of the four-wire portion of the transmission path, including the hybrid, are not included in the specification.

Impulse Noise

The term "Impulse Noise" denotes any momentary occurrence of the noise on a channel over a specified level threshold. It is evaluated by counting the number of occurrences which exceed the threshold.

Individual Case Basis

The term "Individual Case Basis" denotes a condition in which the regulations, if applicable, rates and charges for an offering under the provisions of this tariff are developed based on the circumstances in each case.

** New or Revised*

Continued

DATE ISSUED: July 31, 2002

EFFECTIVE DATE: September 18, 2002

Aloa J. Stevens
Director – State Government Affairs
Citizens Communications Company
4 Triad Center, Suite 200
Salt Lake City, Utah 84180

ACCESS SERVICE

2. General Regulations (Cont'd)

2.6 Definitions (Cont'd)

Initial Address Message (IAM)

The term "Initial Address Message (IAM)" denotes an SS7 message sent in the forward direction to initiate trunk set up with the busying of an outgoing trunk which carries the information about that trunk along with other information relating to the routing and handling of the call to the next switch.

Inserted Connection Loss

The term "Inserted Connection Loss" denotes the 1004 HZ power difference (in dB) between the maximum power available at the originating end and the actual power reaching the terminating end through the inserted connection.

Interexchange Carrier (IC) or Interexchange Common Carrier

The terms "Interexchange Carrier" (IC) or "Interexchange Common Carrier" denotes any individual, partnership, association, joint-stock company, trust, governmental entity, or corporation engaged for hire in intrastate, interstate, or foreign communications by wire or radio, between two or more exchanges.

Intermodulation Distortion

The term "Intermodulation Distortion" denotes a measure of the nonlinearity of a channel. It is measured using four tones, and evaluating the ratios (in dB) of the transmitted composite four-tone signal power to the second-order products of the tones (R2), and the third-order products of the tones (R3).

Interstate Communications

The term "Interstate Communications" denotes both interstate and foreign communications.

** New or Revised*

Continued

DATE ISSUED: July 31, 2002

EFFECTIVE DATE: September 18, 2002

Aloa J. Stevens
Director – State Government Affairs
Citizens Communications Company
4 Triad Center, Suite 200
Salt Lake City, Utah 84180

ACCESS SERVICE

2. General Regulations (Cont'd)

2.6 Definitions (Cont'd)

Intrastate Communications

The term "Intrastate Communications" denotes any communications within a state subject to oversight by a state regulatory commission as provided by the laws of the state involved.

Line Side Connection

The term "Line Side Connection" denotes a connection of a transmission path to the line side of a local exchange switching system.

Local Access and Transport Area

The term "Local Access and Transport Area" (LATA) denotes a geographic area established by the Telephone Company for the provision and administration of its communications service. It encompasses one or more Telephone Company designated exchanges which are configured in relative proximity to one another and may be reconfigured by the Telephone Company in the normal operation of its business. As used herein, the term LATA refers only to these Telephone Company designated exchanges and does not necessarily have any predetermined association with the term LATA used by other exchange carriers.

Loop Around Test Line

The term "Loop Around Test Line" denotes an arrangement utilizing a Telephone Company central office to provide a means to make certain two-way transmission tests on a manual basis. This arrangement has two central office terminations, each reached by means of separate telephone numbers and does not require any specific customer premises equipment. Equipment subject to this test arrangement is at the discretion of the customer.

** New or Revised*

Continued

DATE ISSUED: July 31, 2002

EFFECTIVE DATE: September 18, 2002

Aloa J. Stevens
Director – State Government Affairs
Citizens Communications Company
4 Triad Center, Suite 200
Salt Lake City, Utah 84180

ACCESS SERVICE

2. General Regulations (Cont'd)

2.6 Definitions (Cont'd)

Loss Deviation

The term "Loss Deviation" denotes the variation of the actual loss from the designed value.

Message

The term "Message" denotes a "call" as defined preceding.

Milliwatt (102 Type) Test Line

The term "Milliwatt (102 Type) Test Line" denotes an arrangement in an end office which provides a 1004 Hz tone at 0 dBm0 for one-way transmission measurements towards the customer's premises from the Telephone Company end office.

Network Control Signaling

The term "Network Control Signaling" denotes the transmission of signals used in the telecommunications system which perform functions such as supervision (control, status, and charge signals), address signaling (e.g., dialing), calling and called number identifications, rate of flow, service selection error control and audible tone signals (call progress signals indicating re-order or busy conditions, alerting, coin denominations, coin collect, and coin return tones) to control the operation of the telecommunications system.

Nonsynchronous Test Line

The term "Nonsynchronous Test Line" denotes an arrangement in step-by-step end offices which provides operational tests which are not as complete as those provided by the synchronous test lines, but can be made more rapidly.

** New or Revised*

Continued

DATE ISSUED: July 31, 2002

EFFECTIVE DATE: September 18, 2002

Aloa J. Stevens
Director – State Government Affairs
Citizens Communications Company
4 Triad Center, Suite 200
Salt Lake City, Utah 84180

ACCESS SERVICE

2. General Regulations (Cont'd)

2.6 Definitions (Cont'd)

North American Numbering Plan

The term "North American Numbering Plan" denotes a three digit area (Numbering Plan Area) code and a seven-digit telephone number made up of a three-digit Central office code plus a four-digit station number.

Off-Hook

The term "Off-Hook" denotes the active condition of Switched Access or a Telephone Exchange Service Line.

On-Hook

The term "On-Hook" denotes the idle condition of Switched Access or a Telephone Exchange Service line.

Open Circuit Test Line

The term "Open Circuit Test Line" denotes an arrangement in an end office which provides an a.c. circuit termination of a trunk or line by means of an inductor of several Henries.

Originating Direction

The term "Originating Direction" denotes the use of access service for the origination of calls from an End User Premises to an IC Premises.

Pay Telephone

The term "Pay Telephone" denotes Telephone Company provided instruments and related facilities that are available to the general public for public convenience and necessity, including public and semipublic telephones, and coinless telephones.

** New or Revised*

Continued

DATE ISSUED: July 31, 2002

EFFECTIVE DATE: September 18, 2002

Aloa J. Stevens
Director – State Government Affairs
Citizens Communications Company
4 Triad Center, Suite 200
Salt Lake City, Utah 84180

ACCESS SERVICE

2. General Regulations (Cont'd)

2.6 Definitions (Cont'd)

Phase Jitter

The term "Phase Jitter" denotes the unwanted phase variations of a signal.

Point of Termination

The term "Point of Termination" denotes the point of demarcation at a customer designated premise at which the Telephone Company's responsibility for the provision of Access Service ends.

Premise(s)

The term "Premise(s)" denotes a building or buildings on continuous property (except Railroad Right-of-Way, etc.) not separated by a public highway.

Release Message

The term "Release Message" denotes an SS7 Message sent in either direction to indicate that a specific circuit is being released.

Remote Switching Modules and/or Remote Switching Systems

The term "Remote Switching Modules and/or Remote Switching Systems" denotes remotely controlled electronic end office switches which obtain their call processing capability from an ESS-type Host Office. The Remote Switching Modules and/or Remote Switching Systems cannot accommodate direct trunks to an IC.

Return Loss

The term "Return Loss" denotes a measure of the similarity between the two impedances at the junction of two transmission paths. The higher the return loss, the higher the similarity.

** New or Revised*

Continued

DATE ISSUED: July 31, 2002

EFFECTIVE DATE: September 18, 2002

Aloa J. Stevens
Director – State Government Affairs
Citizens Communications Company
4 Triad Center, Suite 200
Salt Lake City, Utah 84180

ACCESS SERVICE

2. General Regulations (Cont'd)

2.6 Definitions (Cont'd)

Registered Equipment

The term "Registered Equipment" denotes the customer's premises equipment which complies with and has been approved within the Registration Provisions of Part 68 of the FCC's Rules and Regulations.

Serving Wire Center

The term "Serving Wire Center" denotes that Telephone Company designated wire center serving the customer designated premises and used for mileage measurement to determine local transport or circuit mileage charges for Access Service.

Seven Digit Manual Test Line

The term "Seven Digit Manual Test Line" denotes an arrangement which allows the Customer to select balance, milliwatt and synchronous test lines by manually dialing a seven digit number over the associated access connection.

Shortage of Facilities or Equipment

The term "Shortage of Facilities or Equipment" denotes a condition which occurs when the Telephone Company does not have appropriate cable, switching capacity, bridging or, multiplexing equipment, etc., necessary to provide the Access service requested by the customer.

Short Circuit Test Line

The term "Short Circuit Test Line" denotes an arrangement in an end office which provides for an a.c. short circuit termination of a trunk or line by means of a capacitor of at least four microfarads.

** New or Revised*

Continued

DATE ISSUED: July 31, 2002

EFFECTIVE DATE: September 18, 2002

Aloa J. Stevens
Director – State Government Affairs
Citizens Communications Company
4 Triad Center, Suite 200
Salt Lake City, Utah 84180

ACCESS SERVICE

2. General Regulations (Cont'd)

2.6 Definitions (Cont'd)

Signal-to-C-Notched Noise Ratio

The Term "Signal-to-C-Notched Noise Ratio" denotes the ratio in dB of a test signal to the corresponding C-Notched Noise.

Signaling System 7 (SS7)

The term "Signaling System 7 (SS7)" denotes the layered protocol used for standardized common channel signaling in the United States.

Singing Return Loss

The term "Singing Return Loss" denotes the frequency weighted measure of return loss at the edges of the voiceband (200 to 500 Hz and 2500 to 3200 Hz), where singing (instability) problems are most likely to occur.

Subtending End Office of an Access Tandem

The term "Subtending End Office of an Access Tandem" denotes an end office that has final trunk group routing through that tandem.

Synchronous Test Line

The term "Synchronous Test Line" denotes an arrangement in an end office which performs marginal operational tests of supervisory and ring-tripping functions.

Terminating Direction

The term "Terminating Direction" denotes the use of Access Service for the completion of calls from an IC premise to an End User Premise.

** New or Revised*

Continued

DATE ISSUED: July 31, 2002

EFFECTIVE DATE: September 18, 2002

Aloa J. Stevens
Director – State Government Affairs
Citizens Communications Company
4 Triad Center, Suite 200
Salt Lake City, Utah 84180

ACCESS SERVICE

2. General Regulations (Cont'd)

2.6 Definitions (Cont'd)

Transmission Measuring (105 Type) Test Line/Responder

The term "Transmission Measuring (105 Type) Test Line/Responder" denotes an arrangement in an end office which provides far-end access to a responder and permits two-way loss and noise measurements to be made on trunks from a near end office.

Transmission Path

The term "Transmission Path" denotes an electrical path capable of transmitting signals within the range of the service offering, e.g., a voice grade transmission path is capable of transmitting voice frequencies within the approximate range of 300 to 3000 Hz. A transmission path is comprised of physical or derived facilities consisting of any form or configuration of plant typically used in the telecommunications industry.

Trunk

The term "Trunk" denotes a communications path connecting two switching systems in a network, used in the establishment of an end-to-end connection.

Trunk Group

The term "Trunk Group" denotes a set of trunks which are traffic engineered as a unit for the establishment of connections between switching systems in which all of the communications paths are interchangeable.

Trunk Side Connection

The term "Trunk Side Connection" denotes the connection of a transmission path to the trunk side of a local exchange switching system.

** New or Revised*

Continued

DATE ISSUED: July 31, 2002

EFFECTIVE DATE: September 18, 2002

Aloa J. Stevens
Director – State Government Affairs
Citizens Communications Company
4 Triad Center, Suite 200
Salt Lake City, Utah 84180

ACCESS SERVICE

2. General Regulations (Cont'd)

2.6 Definitions (Cont'd)

Two-Wire to Four-Wire Conversion

The term "Two-Wire to Four-Wire Conversion" denotes an arrangement which converts a four-wire transmission path to a two-wire transmission path to allow a four-wire facility to terminate to a two-wire entity (e.g., a central office switch).

Uniform Service Order Code

The term "Uniform Service Order Code" denotes a three or five character alphabetic, numeric, or an alphanumeric code that identifies a specific item of service or equipment. Uniform Service Order Codes are used in the Telephone Company billing system to generate recurring rates and nonrecurring charges.

V&H Coordinates Method

The term "V and H Coordinates Method" denotes a method of computing airline miles between two points by utilizing an established formula which is based on the vertical and horizontal coordinates of the two points.

WATS Serving Office

The term "WATS Serving Office" denotes a Telephone Company switching office capable of performing the optional screening functions used in Combined Access Service Arrangements.

Wire Center

The term "Wire Center" denotes a building in which one or more central offices, including end office switches, used for the provision of Telephone Exchange Services, are located.

** New or Revised*

Continued

DATE ISSUED: July 31, 2002

EFFECTIVE DATE: September 18, 2002

Aloa J. Stevens
Director – State Government Affairs
Citizens Communications Company
4 Triad Center, Suite 200
Salt Lake City, Utah 84180

ACCESS SERVICE

3. Carrier Common Line Access Service

The Telephone Company will provide Carrier Common Line Access Service (Carrier Common Line Access) to customers.

3.1 General Description

Carrier Common Line Access provides for the use of Telephone Company common lines by customers for access to end users to furnish Intrastate Communications.

Carrier Common Line Access is provided where the customer obtains Telephone Company Switched Access Service under this tariff.

Premium Access is (1) All Terminating Switched Access Service, and (2) Originating Switched Access Service provided to ICs under this tariff which furnish intrastate MTS/WATS, and (3) Originating Switched Access Service in an end office converted to equal access.

Nonpremium Access is originating Switched Access Service provided in an end office not yet converted to equal access to customers who do not furnish intrastate MTS/WATS.

3.2 Limitations

- (A) A telephone number is not provided with Carrier Common Line Access.
- (B) Detail billing is not provided for Carrier Common Line Access.
- (C) Directory listings are not included in the rates and charges for Carrier Common Line Access.

** New or Revised*

Continued

DATE ISSUED: July 31, 2002

EFFECTIVE DATE: September 18, 2002

Aloa J. Stevens
Director – State Government Affairs
Citizens Communications Company
4 Triad Center, Suite 200
Salt Lake City, Utah 84180

ACCESS SERVICE

3. Carrier Common Line Access Service (Cont'd)

3.2 Limitations (Cont'd)

- (D) Intercept arrangements are not included in the rates and charges for Carrier Common Line Access.
- (E) All line side connections provided in the same access group will be limited to the same features and operating characteristics.
- (F) All trunk side connections provided in the same access group will be limited to the same features and operating characteristics.
- (G) Where WATS is provided which terminates at a WATS Serving Office, minutes which are carried on that end of the service (i.e., originating minutes for outward WATS and WATS-type services and terminating minutes for inward WATS and WATS-type services) shall not be assessed Carrier Common Line Access per minute charges with the following exception:
 - (1) Carrier Common Line Access per minute charges shall apply when Feature Group A or Feature Group B switched access is ordered from a nonequal access telephone company office that does not have measurement capabilities and the assumed average access minutes, as set forth in Section 6 following, are used.

(T)

Continued

DATE ISSUED: May 9, 2012

EFFECTIVE DATE: July 1, 2012

Kenneth Mason
Vice President – Government & Regulatory Affairs
Citizens Communications Company
180 S. Clinton Ave.
Rochester, NY 14646

ACCESS SERVICE

3. Carrier Common Line Access Service (Cont'd)

3.3 Undertaking of the Telephone Company

- (A) Where the customer is provided with Switched Access Service under other sections of this tariff, the Telephone Company will provide the use of Telephone Company common lines by a customer for access to end users at rates and charges as set forth in 16.1 following.
- (B) Where the customer is reselling MTS and/or MTS-type service(s) on which the Carrier Common Line and Switched Access charges have been assessed, the customer may, at the option of the customer, obtain Feature Group A, Feature Group B, or Feature Group D Switched Access Service under this tariff as set forth in Section 6 following for originating and/or terminating access in the local exchange. Such access group arrangements whether single lines or trunks or multiline hunt groups or trunk groups will have Carrier Common Line Access Charges applied as set forth in 16.1 following.

Resold intrastate inward MTS and MTS-type service(s) shall include collect calls, third number calls and credit card calls where the reseller pays the underlying carrier's service charges; and shall not include interstate minutes of use.

Resold intrastate outward MTS and MTS-type service(s) shall not include collect, third number, credit card, or interstate minutes of use.

** New or Revised*

Continued

DATE ISSUED: July 31, 2002

EFFECTIVE DATE: September 18, 2002

Aloa J. Stevens
Director – State Government Affairs
Citizens Communications Company
4 Triad Center, Suite 200
Salt Lake City, Utah 84180

ACCESS SERVICE

3. Carrier Common Line Access Service (Cont'd)

3.3 Undertaking of the Telephone Company (Cont'd)

- (C) When access to the local exchange is required to provide a customer service (e.g., MTS/WATS-type, telex, Data, etc.) that uses a resold Private Line Service, Switched Access Service Rates and Regulations, as set forth in Section 6 following, will apply, except when such access to the local exchange is required for the provision of an enhanced service. Carrier Common Line Access rates and charges as set forth in 16.1 following in accordance with the regulations as set forth in 3.7(E) following.
- (D) The Switched Access Service provided by the Telephone Company includes the Switched Access Service provided for both interstate and intrastate communications and the Carrier Common Line Access rates and charges as set forth in 16.1 following apply in accordance with the regulations as set forth in 3.7(E) following.
- (E) When the IC is provided Operator Trunk-Coin or Combined Coin and Non-Coin or Operator Trunk-Full Feature Optional Features for sent-paid pay telephone access as set forth in Section 6 following, the Telephone Company will collect sent-paid monies from pay telephone stations and will remit monies to the IC as set forth in 3.6 following. The Telephone Company will provide message call detail format and bill periods used to determine the monies upon request from the IC.

** New or Revised*

Continued

DATE ISSUED: July 31, 2002

EFFECTIVE DATE: September 18, 2002

Aloa J. Stevens
Director – State Government Affairs
Citizens Communications Company
4 Triad Center, Suite 200
Salt Lake City, Utah 84180

ACCESS SERVICE

3. Carrier Common Line Access Service (Cont'd)

3.4 Obligations of the Customer

- (A) The Switched Access Service associated with Carrier Common Line Access shall be ordered by the customer under other sections of this tariff.
- (B) The customer facilities at the premises of ordering customer shall provide the necessary on-hook and off-hook supervision.
- (C) Unless the customer reports (1) intrastate use as set forth in (D) following or (2) Feature Group A, B, or D Switched Access Service as set forth in (F) following, all Switched Access Service provided to the customer will be subject to Carrier Common Line Access charges.
- (D) When the customer reports interstate and intrastate use of Switched Access Service, the associated Carrier Common Line Access used by the customer for intrastate will be determined as set forth in 3.7(E) following.
- (E) Where Feature Group C end office switching is provided without Telephone Company recording and the IC records minutes of use which will be used to determine Carrier Common Line Access charges (i.e., Feature Group C operator and TSPS calls such as pay telephone sent-paid, operator-DDD, operator-person, collect, credit-card, third number, and/or other like calls), the IC shall furnish such minutes of use detail to the Telephone Company in a timely manner. If the IC does not furnish the data to the Telephone Company, the IC

** New or Revised*

Continued

DATE ISSUED: July 31, 2002

EFFECTIVE DATE: September 18, 2002

Aloa J. Stevens
Director – State Government Affairs
Citizens Communications Company
4 Triad Center, Suite 200
Salt Lake City, Utah 84180

ACCESS SERVICE

3. Carrier Common Line Access Service (Cont'd)3.4 Obligations of the Customer (Cont'd)

(E) (Cont'd)

shall identify all Switched Access Services which could carry such calls in order for the billing entity to accumulate the minutes of use through the use of special Telephone Company measuring and recording equipment.

(F) When the customer is reselling MTS and/or MTS-type service as set forth in 3.3(B) preceding, the customer will be charged the Carrier Common Line Access charges in accordance with the regulations as set forth in 3.7(D) following if the customer or the provider of the MTS service furnishes documentation of the MTS usage and/or the customer furnishes documentation of the MTS-type usage. Such documentation supplied by the customer shall be supplied each month and shall identify the involved resold MTS and/or MTS-type services. The monthly period used to determine the minutes of use for resold MTS and/or MTS-type service(s) shall be the most recent monthly period for which the customer has received a bill for such resold MTS and/or MTS-type service(s). This information shall be delivered to the Telephone Company, at a location specified by the Telephone Company, no later than 15 days after the bill date shown on the resold MTS and/or MTS-type service bill. If the required information is not received by the Telephone Company, the previously reported information, as described preceding, will be used for the next two months. For any subsequent month, no allocation or credit will be made until the required documentation is delivered to the Telephone Company by the customer.

** New or Revised**Continued*

DATE ISSUED: July 31, 2002

EFFECTIVE DATE: September 18, 2002

Aloa J. Stevens
Director – State Government Affairs
Citizens Communications Company
4 Triad Center, Suite 200
Salt Lake City, Utah 84180

ACCESS SERVICE

3. Carrier Common Line Access Service (Cont'd)3.4 Obligations of the Customer (Cont'd)

- (G) When the customer orders Switched Access Service as set forth in (F) preceding, the Telephone Company or the billing entity may request when resold MTS is involved, a certified copy of the customer's MTS usage billing from either the customer or the provider of the MTS Service and/or when resold MTS-type service is involved, a certified copy of the customer's MTS-type usage billing from either the customer or the provider of the MTS-type service. The requests for this billing will relate back no more than 12 months prior to the current billing period.
- (H) Where Operator Trunk-Coin or Combined Coin and Non-Coin or Operator Trunk-Full Feature Optional Features for sent-paid pay telephone access is provided to the IC and the IC wishes to receive the monies it is due for the monies collected by the Telephone Company from coin pay telephone stations, the IC shall furnish to the Telephone Company, at a location specified by the Telephone Company, the IC message call detail for the IC sent-paid (coin) pay telephone calls in accordance with the Telephone Company collection schedule. The IC message call detail furnished shall be in a standard format established by the Telephone Company. If no IC message call detail is received from the IC for each bill period established by the Telephone Company, the Telephone Company will assume there were no IC sent-paid (coin) pay telephone calls for the period. In addition the IC shall furnish a schedule of its

** New or Revised**Continued*

DATE ISSUED: July 31, 2002

EFFECTIVE DATE: September 18, 2002

Aloa J. Stevens
Director – State Government Affairs
Citizens Communications Company
4 Triad Center, Suite 200
Salt Lake City, Utah 84180

ACCESS SERVICE

3. Carrier Common Line Access Service (Cont'd)

3.4 Obligations of the Customer (Cont'd)

(H) (Cont'd)

charges for sent-paid (coin) calls to the Telephone Company at a location and date as specified by the Telephone Company. Any change in the IC's schedule of charges shall be furnished to the Telephone Company one day after the change becomes effective.

3.5 Payment Arrangements

(A) The Telephone Company will bill the Carrier Common Line Access. The bill day (i.e., the billing date of the bill) in a month for each customer account will be established by the Telephone Company. Payment is due from the customer 31 days after the bill day date (payment date) or by the next bill date (i.e., same date in the following month as the bill date), whichever is the shortest interval, and is payable in immediately available funds. If such payment date is a Saturday, Sunday, or Holiday (i.e., New Year's Day, Independence Day, Labor Day, Thanksgiving Day, Christmas Day, the second Tuesday in November, and a day when Washington's Birthday, Memorial Day, or Columbus Day is legally observed), payment will be due from the customer as follows:

If such payment date falls on a Sunday or on a Holiday which is observed on a Monday, the payment date shall

** New or Revised*

Continued

DATE ISSUED: July 31, 2002

EFFECTIVE DATE: September 18, 2002

Aloa J. Stevens
Director – State Government Affairs
Citizens Communications Company
4 Triad Center, Suite 200
Salt Lake City, Utah 84180

ACCESS SERVICE

3. Carrier Common Line Access Service (Cont'd)3.5 Payment Arrangements (Cont'd)

(A) (Cont'd)

be the first non-Holiday day following such Sunday or Holiday. If such payment date falls on a Saturday or on a Holiday which is observed on Tuesday, Wednesday, Thursday, or Friday, the payment date shall be the last non-Holiday day preceding such Saturday or Holiday.

(B) Further, if any portion of the Carrier Common Line Access payment is received by the Telephone Company after the payment date as set forth in (A) preceding, or if any portion of the Carrier Common Line Access payment is received by the Telephone Company in funds which are not immediately available, then a late payment penalty shall be due to the Telephone Company. The late payment penalty shall be the portion of the Carrier Common Line Access payment not received by the payment date times a late factor. The late factor shall be the lesser of:

- (1) the highest interest rate (in decimal value) which may be levied by law for commercial transactions, compounded daily for the number of days from the payment date to and including the date that the customer actually makes the payment to the Telephone Company, or
- (2) 0.000590 per day, compounded daily for the number of days from the payment date to and including the date that the customer actually makes the payment to the Telephone Company.

* *New or Revised*

Continued

DATE ISSUED: July 31, 2002

EFFECTIVE DATE: September 18, 2002

Aloa J. Stevens
Director – State Government Affairs
Citizens Communications Company
4 Triad Center, Suite 200
Salt Lake City, Utah 84180

ACCESS SERVICE

3. Carrier Common Line Access Service (Cont'd)

3.5 Payment Arrangements (Cont'd)

- (C) In the event a billing dispute concerning a month's Carrier Common Line Access billed to the customer by the Telephone Company is resolved in favor of the Telephone Company, any payments withheld pending settlement of the dispute shall be subject to the late payment penalty set forth in (B) preceding. If the customer disputes the bill on or before the payment date, and pays the undisputed amount on or before the payment date, any late payment charge for the disputed amount will not start until 10 days after the payment date. If the billing dispute is resolved in favor of the customer, no late payment penalty will apply to the disputed amount. In addition, if the customer disputes the billed amount and pays the total amount (i.e., the nondisputed amount and the disputed amount) on or before the payment date and the billing dispute is resolved in the favor of the customer, the customer will receive a credit for a disputed amount penalty from the Telephone Company if the billing dispute is not resolved within 10 working days following the payment date or the date the customer furnishes to the Telephone Company documentation to support its claim plus 10 working days, whichever date is the later date. The disputed amount penalty shall be the disputed amount resolved in the customer's favor times a penalty factor.

** New or Revised*

Continued

DATE ISSUED: July 31, 2002

EFFECTIVE DATE: September 18, 2002

Aloa J. Stevens
Director – State Government Affairs
Citizens Communications Company
4 Triad Center, Suite 200
Salt Lake City, Utah 84180

ACCESS SERVICE

3. Carrier Common Line Access Service (Cont'd)3.6 Payment of Coin Sent-Paid Monies

The Telephone Company will collect the monies from coin pay telephone stations and will determine and remit amounts due to an IC which is provided Operator Trunk-Coin or Combined Coin and Non-Coin or Operator Trunk-Full Feature Optional Features for sent-paid pay telephone access as follows:

(A) Bill Period Coin Revenue

The Telephone Company will establish a collection schedule for each coin pay telephone station and will collect the monies from the coin pay stations based on this collection schedule. The monies collected based on this schedule during each bill period established by the Telephone Company will be identified by coin pay telephone station and summed to develop the Bill Period Coin Revenue for each coin record day (i.e., the day a record is prepared and dated to show the amount due the IC).

(B) Total IC Coin Revenue

The intrastate Total IC Coin Revenue will be determined by the Telephone Company based on the customer message call detail received from the customer for each bill period and the IC's schedule of charges for sent-paid coin calls. Such Total Customer Coin Revenue will be developed each coin record day.

** New or Revised**Continued*

DATE ISSUED: July 31, 2002

EFFECTIVE DATE: September 18, 2002

Aloa J. Stevens
Director – State Government Affairs
Citizens Communications Company
4 Triad Center, Suite 200
Salt Lake City, Utah 84180

ACCESS SERVICE

3. Carrier Common Line Access Service (Cont'd)

3.6 Payment of Coin Sent-Paid Monies (Cont'd)

(C) Recourse Adjustments

For each coin record day, the Telephone Company will subtract from the Total IC Coin Revenue an amount for coin station shortages. Coin station shortages are amounts resulting from unauthorized calling at coin pay telephone stations, use of unauthorized coins (i.e., foreign coins, slugs, and improper use of U.S. pennies), unauthorized removal of coins from coin pay telephone stations, and coin refunds beyond the Telephone Company's control. Such amount for coin station shortages will be developed by the Telephone Company by multiplying the Total IC Coin Revenue for each coin record day by a shortage factor. Such amount will be rounded to the nearest penny. The shortage factor will be determined by dividing the yearly total coin shortage amount by the yearly total coin revenue amount (i.e., total coin revenue equals the coin revenue due under exchange tariffs, state toll tariffs, and interstate toll tariffs). The total coin shortage amount and the total revenue amount will be determined by the Telephone Company through an annual special study.

(D) Payment of Net IC Coin Revenue

The Telephone Company will determine the Net IC Coin Revenue for each coin record day by subtracting from the Total IC Coin Revenue determined as set forth in (B) preceding the amount for coin station shortages determined as set forth

** New or Revised*

Continued

DATE ISSUED: July 31, 2002

EFFECTIVE DATE: September 18, 2002

Aloa J. Stevens
Director – State Government Affairs
Citizens Communications Company
4 Triad Center, Suite 200
Salt Lake City, Utah 84180

ACCESS SERVICE

3. Carrier Common Line Access Service (Cont'd)

3.6 Payment of Coin Sent-Paid Monies (Cont'd)

(D) Payment of Net IC Coin Revenue (Cont'd)

in (C) preceding. On the date (payment date) determined by adding 45 days to the coin record day, the Telephone Company will remit payment to the IC for the Net IC Coin Revenue.

(E) Audit Provisions

Upon reasonable written notice by the customer to the Telephone Company, the customer shall have the right through its authorized representative to examine and audit, during normal business hours and at reasonable intervals as determined by the Telephone Company, all such records and accounts as may, under recognized accounting practices, contain information bearing upon the determination of the amount payable to the customer. Adjustment shall be made by the proper party to compensate for any errors or omissions disclosed by such examination or audit. Neither such right to examine and audit nor the right to receive such adjustment shall be affected by any statement to the contrary, appearing on checks or otherwise, unless such statement expressly waiving such right appears in a letter signed by the authorized representative of the party having such right and delivered to the other party.

** New or Revised*

Continued

DATE ISSUED: July 31, 2002

EFFECTIVE DATE: September 18, 2002

Aloa J. Stevens
Director – State Government Affairs
Citizens Communications Company
4 Triad Center, Suite 200
Salt Lake City, Utah 84180

ACCESS SERVICE

3. Carrier Common Line Access Service (Cont'd)

3.6 Payment of Coin Sent-Paid Monies (Cont'd)

(E) Audit Provisions (Cont'd)

All information received or reviewed by the customer or its authorized representative is to be considered confidential and is not to be distributed, provided or disclosed in any form to anyone not involved in the audit, nor is such information to be used for any other purpose.

3.7 Rate Regulations

- (A) The Transitional Charges will be billed to each Switched Access Service provided under this tariff in accordance with the regulations as set forth in (E) following, except as set forth in (D) and (F) following.
- (B) When access minutes are used to determine the Transitional Charges, they will be accumulated using call detail recorded by Telephone Company equipment except as set forth in (C) following and Feature Group C operator and TSPS call detail such as pay telephone sent-paid, operator-DDD, operator-person, collect, credit-card, third number, and/or other like calls recorded by the customer. The Telephone Company measuring and recording equipment except as set forth in (C) following will be associated with end office or local tandem switching equipment and will record each originating and terminating access minute where answer supervision is received. The accumulated access minutes will be summed on a line by line basis, by line group or by end office, whichever type of account is used by the Telephone Company, for each customer and then rounded to the nearest minute.

** New or Revised*

Continued

DATE ISSUED: July 31, 2002

EFFECTIVE DATE: September 18, 2002

Aloa J. Stevens
Director – State Government Affairs
Citizens Communications Company
4 Triad Center, Suite 200
Salt Lake City, Utah 84180

ACCESS SERVICE

3. Carrier Common Line Access Service (Cont'd)

3.7 Rate Regulations (Cont'd)

- (C) When Carrier Common Line Access is provided in association with Feature Group A or Feature Group B Switched Access Service in Telephone Company offices that are not equipped for measurement capabilities, an assumed average intrastate access minutes will be used to determine the Transitional Charges. These assumed access minutes are as set forth in Section 6 of this tariff. (T)
- (D) When the customer is provided an access group to be used in conjunction with the resale of MTS and/or MTS-type services as set forth in 3.3(B) preceding, subject to the limitations of Carrier Common Line as set forth in 3.2 preceding, and the billing entity receives the usage information required to calculate the proration of Carrier Common Line as set forth in 3.4(F) preceding, the customer will be billed as set forth in (1), (2) or (3) following.

When the customer is provided with more than one access group in a LATA in association with the resale of MTS and/or MTS-type services, the resold minutes of use will be apportioned as follows:

The billing entity will apportion the resold outward MTS and/or MTS-type services and originating minutes of use for which resale credit applies, among the access groups. Such apportionment will be based on the relationship of the

Continued

DATE ISSUED: May 9, 2012

EFFECTIVE DATE: July 1, 2012

Kenneth Mason
Vice President – Government & Regulatory Affairs
Citizens Communications Company
180 S. Clinton Ave.
Rochester, NY 14646

ACCESS SERVICE

3. Carrier Common Line Access Service (Cont'd)

3.7 Rate Regulations (Cont'd)

(D) (Cont'd)

originating usage for each access group to the total originating usage for all access groups in the LATA. For purposes of administering this provision:

Resold outward MTS and/or MTS-type services minutes shall be only those attributable to intrastate outward MTS and/or MTS-type minutes and shall not include collect, third number, credit card, or interstate minutes of use.

The resale credit shall apply for resold outward MTS and MTS-type services and minutes of use, provided Carrier Common Line and Switched Access Charges have been assessed on such services.

The billing entity will apportion the resold inward MTS and/or MTS-type services and terminating minutes of use for which resale credit applies, among the access groups. Such apportionment will be based on the relationship of the terminating usage for each access group to the total terminating usage for all access groups in the LATA. For purposes of administering this provision:

Resold inward MTS and/or MTS-type services minutes shall be only those attributable to intrastate inward MTS/MTS-type (i.e., collect calls, third number calls, and credit card calls) and shall not include interstate minutes of use or MTS/MTS-type minutes of use paid for by another party.

** New or Revised*

Continued

DATE ISSUED: July 31, 2002

EFFECTIVE DATE: September 18, 2002

Aloa J. Stevens
Director – State Government Affairs
Citizens Communications Company
4 Triad Center, Suite 200
Salt Lake City, Utah 84180

ACCESS SERVICE

3. Carrier Common Line Access Service (Cont'd)

3.7 Rate Regulations (Cont'd)

(D) (Cont'd)

The resale credit shall apply for resold inward MTS and MTS-type services and minutes of use, provided Carrier Common Line and Switched Access Charges have been assessed on such services.

In order for the rate regulations to apply as set forth in (1), (2) or (3) following, the access groups and the resold MTS and/or MTS-type services must be provided in the same state (except when the same extended area service arrangement is provided in two different states by the same telephone company) in the same exchange, provided by the same telephone company and connected directly or indirectly. For those exchanges that encompass more than one state, the customer shall report the information by state within the exchange.

Each of the access group arrangements used by the customer in association with the resold MTS and/or MTS-type services must be connected either directly or indirectly to the customer designated premises at which the resold MTS and/or MTS-type services are terminated. Direct connections are those arrangements where the access groups and resold MTS and/or MTS-type services are terminated at the same customer designated premises.

Indirect outward connections are those arrangements where the access groups and the resold outward MTS and/or MTS-type services are terminated at different customer designated

** New or Revised*

Continued

DATE ISSUED: July 31, 2002

EFFECTIVE DATE: September 18, 2002

Aloa J. Stevens
Director – State Government Affairs
Citizens Communications Company
4 Triad Center, Suite 200
Salt Lake City, Utah 84180

ACCESS SERVICE

3. Carrier Common Line Access Service (Cont'd)3.7 Rate Regulations (Cont'd)

(D) (Cont'd)

premises in the same exchange. Such different customer designated premises are connected by facilities that permit a call to flow from access groups to resold MTS and/or MTS-type services.

Indirect inward connections are those arrangements where the access groups and resold inward MTS and/or MTS-type services are terminated at different customer designated premises in the same exchange. Such different customer designated premises are connected by facilities that permit a call to flow from resold inward MTS and/or MTS-type services to access groups.

The adjustments as set forth following will be computed separately for each access group.

(1) Access Groups - Non-Equal Access Offices Only

When all the usage on an access group originates from end offices that have not been converted to equal access the Nonpremium Access Charge per minute as set forth in 3.8 following will apply to only originating minutes of use. The minutes billed Carrier Common Line Access charges will be the adjusted terminating intrastate access minutes plus the adjusted originating intrastate access minutes for such access groups.

** New or Revised**Continued*

DATE ISSUED: July 31, 2002

EFFECTIVE DATE: September 18, 2002

Aloa J. Stevens
Director – State Government Affairs
Citizens Communications Company
4 Triad Center, Suite 200
Salt Lake City, Utah 84180

ACCESS SERVICE

3. Carrier Common Line Access Service (Cont'd)3.7 Rate Regulations (Cont'd)

(D) (Cont'd)

(1) Access Groups - Non-Equal Access Offices Only (Cont'd)

The adjusted originating access minutes will be the originating intrastate access minutes less the reported resold outward MTS and/or MTS-type service minutes of use as set forth in this section preceding; but not less than zero.

(2) Access Groups - Equal Access Offices Only

When all the usage on an access group originates from and/or terminates at end offices that have been converted to equal access the Premium Access Charge per minute as set forth in 16.1 following will apply. The minutes billed Carrier Common Line Access Service charges will be the adjusted terminating intrastate access minutes and the adjusted originating intrastate access minutes for such access groups.

The adjusted terminating access minutes will be the terminating intrastate access minutes less the reported resold inward MTS and/or MTS-type service minutes of use as set forth in this section preceding; but not less than zero. The adjusted originating access minutes will be the originating intrastate access minutes less the reported resold outward MTS and/or MTS-type service minutes of use; but not less than zero.

** New or Revised**Continued*

DATE ISSUED: July 31, 2002

EFFECTIVE DATE: September 18, 2002

Aloa J. Stevens
Director – State Government Affairs
Citizens Communications Company
4 Triad Center, Suite 200
Salt Lake City, Utah 84180

ACCESS SERVICE

3. Carrier Common Line Access Service (Cont'd)

3.7 Rate Regulations (Cont'd)

(D) (Cont'd)

(3) Access Groups - Non-Equal Access and Equal Access Offices

When an access group has usage that originates from end offices that have been converted to equal access and end offices that have not been converted, both transitional premium and nonpremium per minute charges as set forth in 16.1 following will apply. The minutes billed Carrier Common Line Access Service charges will be the adjusted terminating intrastate access minutes plus the adjusted originating intrastate access minutes for such access groups.

The adjusted originating access minutes will be the originating intrastate access minutes less the reported resold outward MTS and/or MTS-type service minutes of use as set forth in this section preceding; but not less than zero.

The adjusted originating access minutes will be apportioned between premium and nonpremium access minutes using end-office specific usage data when available, or when usage data are not available, the premium and nonpremium ratios developed as set forth in Section 6 following. The Premium and Nonpremium per minute charges set forth in 16.1 following

(T)

Continued

DATE ISSUED: May 9, 2012

EFFECTIVE DATE: July 1, 2012

Kenneth Mason
Vice President – Government & Regulatory Affairs
Citizens Communications Company
180 S. Clinton Ave.
Rochester, NY 14646

ACCESS SERVICE

3. Carrier Common Line Access Service (Cont'd)3.7 Rate Regulations (Cont'd)

(D) (Cont'd)

(3) Access Groups - Non-Equal Access and Equal Access Offices (Cont'd)

will apply as appropriate to the premium and nonpremium access minutes determined in this manner.

(4) The adjustment as set forth in (1), (2), and (3) preceding will be made to the involved customer account no later than either the next bill date, or the one subsequent to that, depending on when the usage report is obtained.

(5) When the MTS and/or MTS-type usage is shown in hours, the number of hours shall be multiplied by 60 to develop the associated MTS and/or MTS-type minutes of use. If the MTS and/or MTS-type usage is shown in a unit that does not show hours or minutes, the customer shall provide a factor to convert the shown units to minutes.

(6) The adjustment as set forth in (1), (2), and (3) preceding will be made to the involved customer account after making the adjustments to the customer account as set forth in (E) following.

(E) When the customer reports interstate and intrastate use of in-service Switched Access Service, the Carrier Common Line Access Transitional Charges will be billed only to intrastate Switched Access Service access minutes based on the data

* *New or Revised**Continued*

DATE ISSUED: July 31, 2002

EFFECTIVE DATE: September 18, 2002

Aloa J. Stevens
Director – State Government Affairs
Citizens Communications Company
4 Triad Center, Suite 200
Salt Lake City, Utah 84180

ACCESS SERVICE

3. Carrier Common Line Access Service (Cont'd)

3.7 Rate Regulations (Cont'd)

(E) (Cont'd)

reported by the customer as set forth in Section 6 following. The (T)
intrastate Switched Access Service access minutes will, after
adjustment as set forth in (D) preceding, when necessary, be
used to determine the Carrier Common Line Charges as set forth
in (F) following.

(F) After the adjustments as set forth in (D) and (E) preceding have
been applied, when necessary, to the Switched Access Service
access minutes, the charges for the involved customer account
will be determined as follows:

- (1) The access minutes for all premium-rated Switched Access
Service subject to Carrier Common Line charges will be
multiplied by the Transitional Charge - Premium Access per
minute rate as set forth in 16.1 following to determine the
charges.
- (2) Carrier Common Line charges shall not be reduced as set
forth in 3.3(B) preceding unless Switched Access Charges,
as set forth in Section 6 following, are applied to the
customer's Switched Access Services.

Continued

DATE ISSUED: May 9, 2012

EFFECTIVE DATE: July 1, 2012

Kenneth Mason
Vice President – Government & Regulatory Affairs
Citizens Communications Company
180 S. Clinton Ave.
Rochester, NY 14646

ACCESS SERVICE

3. Carrier Common Line Access Service (Cont'd)

3.7 Rate Regulations (Cont'd)

(F) (Cont'd)

- (3) The terminating per minute charge(s) apply to all terminating access minutes of use, plus all originating access minutes of use associated with calls placed to 800 and/or 900 numbers, plus all originating access minutes of use associated with FGA Access Services where the off-hook supervisory signaling is forwarded by the customer's equipment when the called party answers.
- (4) The originating Access, per minute charge(s) apply to all originating access minutes of use, less those originating access minutes of use associated with calls placed to 800 and/or 900 numbers and less those originating access minutes of use associated with FGA Access Services where the off-hook supervisory signalling is forwarded by the customer's equipment when the called party answers.

** New or Revised*

Continued

DATE ISSUED: July 31, 2002

EFFECTIVE DATE: September 18, 2002

Aloa J. Stevens
Director – State Government Affairs
Citizens Communications Company
4 Triad Center, Suite 200
Salt Lake City, Utah 84180

ACCESS SERVICE

4. Reserved for future use.

** New or Revised*

Continued

DATE ISSUED: July 31, 2002

EFFECTIVE DATE: September 18, 2002

Aloa J. Stevens
Director – State Government Affairs
Citizens Communications Company
4 Triad Center, Suite 200
Salt Lake City, Utah 84180

ACCESS SERVICE

5. Ordering Switched Access and Special Access Service

This section sets forth the regulations and order related charges for Access Orders for Switched Access Services. These charges are in addition to other applicable charges as set forth in other sections of this tariff.

5.1 Access Service Request Requirements

An Access Service Request (ASR) is used by the Telephone Company to provide the customer with Switched Access Service as set forth in Section 6 following, and Special Access Service as set forth in Section 7 following or to provide changes to existing services.

When placing an order for Access Services, the customer must complete a Telephone Company Access Service Request and shall provide the information as required in 5.1.1, 5.1.2, and 5.1.3 following.

5.1.1 General

A customer may order any number of services of the same type and between the same premises on a single Access Service Request. All details for services for a particular order must be identical except for those for multipoint service.

A customer may order access service on behalf of the customer's end user. The customer must provide the Telephone Company all the necessary information as set forth in this section.

The customer shall provide all information necessary for the Telephone Company to provide and bill for the requested service. In addition to the order information required in 5.1.2 and 5.1.3 following, the customer must also provide:

- Customer name and premise address(es)
- Billing name and address (when different from customer name and address).

** New or Revised*

Continued

DATE ISSUED: July 31, 2002

EFFECTIVE DATE: September 18, 2002

Aloa J. Stevens
Director – State Government Affairs
Citizens Communications Company
4 Triad Center, Suite 200
Salt Lake City, Utah 84180

ACCESS SERVICE

5. Ordering Switched and Special Access Service (Cont'd)

5.1 Access Service Request Requirements (Cont'd)

5.1.1 General (Cont'd)

- Customer contact name(s) and telephone number(s) for the following provisioning activities:

Order negotiation
Order confirmation
Interactive design
Installation
Billing.

5.1.2 Switched Access Ordering Requirements

Switched Access Service may be ordered by the customer on the basis of line-side or trunk-side access connections at Telephone Company locations. Trunk side ordering regulations are as set forth in 5.1.2(A) following. Line side ordering regulations are as set forth in 5.1.2(B) following.

(A) Trunk Side Access Services

Feature Groups B,C,D and 800 Access services are provided by the Telephone Company via trunk side connections. Trunk side services may be ordered at the option of the customer, in BHMCs or in trunk quantities. 800 Access Service Trunks are provided only at Telephone Company designated switches capable of performing the customer identification function for 800 service. When direct routing of 800 Access Service traffic via 800 Access Service trunks is desired, or when the customer's 800 Access Service traffic is combined in the same trunk group arrangement with the customer's FGC or FGD traffic, the customer must complete an Access Service Request as set forth in (1) or (2) following.

** New or Revised*

Continued

DATE ISSUED: July 31, 2002

EFFECTIVE DATE: September 18, 2002

Aloa J. Stevens
Director – State Government Affairs
Citizens Communications Company
4 Triad Center, Suite 200
Salt Lake City, Utah 84180

ACCESS SERVICE

5. Ordering Switched and Special Access Service (Cont'd)

5.1 Access Service Request Requirements (Cont'd)

5.1.2 Switched Access Ordering Requirements (Cont'd)

(A) Trunk Side Access Services (Cont'd)

(1) Trunk Ordering

Customers may order Feature Groups B, C, or D and 800 Access Services by specifying the number of trunks desired between their premises and the end office when direct routing to the end office is desired or the access tandem switch when routing is desired via an access tandem switch and the Local Transport and Local Switching Options desired. When ordering by trunk quantities rather than BHC quantities to an access tandem, the customer must also provide to the Telephone Company a Traffic Distribution Request specifying an estimate of the amount of traffic it will generate to and/or from each end office subtending the access tandem to assist the Telephone Company in its own efforts to project further facility requirements. The major traffic types and directionality must also be specified to enable efficient provisioning and billing functions.

There are two major traffic types identified as Originating and Terminating traffic. Because some customers will wish to further segregate their originating traffic into separate trunk groups, originating traffic may be further categorized into Domestic, 800, 900, Operator and IDDD.

When a customer orders Feature Group B, C, or D or 800 Access Service in trunks, the customer is responsible to assure that sufficient access facilities have been ordered to handle this traffic.

** New or Revised*

Continued

DATE ISSUED: July 31, 2002

EFFECTIVE DATE: September 18, 2002

Aloa J. Stevens
Director – State Government Affairs
Citizens Communications Company
4 Triad Center, Suite 200
Salt Lake City, Utah 84180

ACCESS SERVICE

5. Ordering Switched and Special Access Service (Cont'd)

5.1 Access Service Request Requirements (Cont'd)

5.1.2 Switched Access Ordering Requirements (Cont'd)

(A) Trunk Side Access Services (Cont'd)

(2) BHMC Ordering

Customers may order Feature Groups B, C, and D or 800 Access Switched Access Service by specifying the number of busy hour minutes of capacity (BHMC) from the customer's premises to the end office by Switched Access arrangement and by type of BHMC. This information is used to determine the number of transmission paths as set forth in Section 6 following. The customer then specifies the Local Transport and Local Switching options desired, and for FGB the manner in which intrastate communications shall be completed. (T)

The BHMC may be determined by the customer in the following manner. For each day (8 am to 11 pm, Monday through Friday, excluding national holidays), the customer shall determine the highest number of minutes of use for a single hour (e.g., 55 minutes in the 10-11 am hour). The customer shall, for the same hour period (i.e., busy hour) for each of twenty consecutive business days, pick the twenty consecutive business days in a calendar year which add up to the largest number of minutes of use. Both originating and terminating minutes shall be included. The customer shall then determine the average busy hour minutes of capacity (i.e., BHMC) by dividing the largest number of minutes of use figure for the same hour period for the consecutive twenty business day period by 20. This computation shall be performed for each end office

Continued

DATE ISSUED: May 9, 2012

EFFECTIVE DATE: July 1, 2012

Kenneth Mason
Vice President – Government & Regulatory Affairs
Citizens Communications Company
180 S. Clinton Ave.
Rochester, NY 14646

ACCESS SERVICE

5. Ordering Switched and Special Access Service (Cont'd)

5.1 Access Service Request Requirements (Cont'd)

5.1.2 Switched Access Ordering Requirements (Cont'd)

(A) Trunk Side Access Services (Cont'd)

(2) BHMC Ordering (Cont'd)

the customer wishes to serve. These determinations thus establish the forecasted BHMC for each end office.

BHMCs are differentiated by type and directionality of traffic carried over a Switched Access Service arrangement. Differentiation of traffic among BHMC types is necessary for the Telephone Company to properly design Switched Access Service to meet the traffic carrying capacity requirement of the customer. There are two major BHMC categories identified as Originating and Terminating. Because some customers will wish to further segregate their originating traffic into separate trunk groups, originating BHMCs are further categorized into Domestic, 800, 900, Operator, and IDDD.

(3) 800 NXX Code Activation/Deactivation

800 Access Service NXX Code Activation or Deactivation shall be ordered by the customer for an entire Telephone Company jurisdiction. Telephone Company jurisdiction is set forth on Page 1 preceding. The customer must specify in its Access Service Request, the 800 NXX codes to be activated or deactivated in a Telephone Company jurisdiction.

** New or Revised*

Continued

DATE ISSUED: July 31, 2002

EFFECTIVE DATE: September 18, 2002

Aloa J. Stevens
Director – State Government Affairs
Citizens Communications Company
4 Triad Center, Suite 200
Salt Lake City, Utah 84180

ACCESS SERVICE

5. Ordering Switched and Special Access Service (Cont'd)

5.1 Access Service Request Requirements (Cont'd)

5.1.2 Switched Access Ordering Requirements (Cont'd)

(A) Trunk Side Access Services (Cont'd)

(3) 800 NXX Code Activation/Deactivation (Cont'd)

When a customer's 800 Access Service traffic originates from a Telephone Company end office which is not capable of performing the customer identification function the customer may be required, upon reasonable notice, to provide the Telephone Company an estimate of the amount of traffic it will generate from the end office to assist the Telephone Company in its own efforts to project future facility requirements.

For additions and/or deletions of 800 Access Service NXX(s) subsequent to the initial order for service, the customer shall place an Access Service Request for such additions and/or deletions at least 30 days prior to the effective date of the change in order to allow the Telephone Company sufficient time to implement the change. Calls originating in Telephone Company jurisdictions to NXXs which the customer has not ordered activated will be blocked in those end offices or access tandems which possess the technical capabilities to block such calls.

** New or Revised*

Continued

DATE ISSUED: July 31, 2002

EFFECTIVE DATE: September 18, 2002

Aloa J. Stevens
Director – State Government Affairs
Citizens Communications Company
4 Triad Center, Suite 200
Salt Lake City, Utah 84180

 ACCESS SERVICE

5. Ordering Switched and Special Access Service (Cont'd)5.1 Access Service Request Requirements (Cont'd)5.1.2 Switched Access Ordering Requirements (Cont'd)(B) Line Side Access Services

Feature Group A Access Service is provided by the Telephone Company via line-side connections. All customers shall provide the ordering requirements as follows:

For Feature Group A Switched Access Service, the customer shall specify the number of lines and the first point of switching (i.e., dial tone office), the Local Transport options and Local Switching options desired, and the manner in which intrastate communications shall be completed. In addition, the customer shall also Specify, which lines are to be arranged in multiline hunt group arrangements and which lines are to be provided as single lines.

When Feature Group A is ordered the customer shall specify whether or not the terminating traffic is to be restricted to the FGA Access Area (local exchange calling area) as set forth in Section 6 following or allowed to extend beyond the FGA Access area but within the LATA. When Feature Group A traffic is terminated beyond the Access Area but remains within the LATA, the rates for Switched Access as set forth in Section 6 following, will apply.

(T)

(T)

Continued

DATE ISSUED: May 9, 2012

EFFECTIVE DATE: July 1, 2012

Kenneth Mason
 Vice President – Government & Regulatory Affairs
 Citizens Communications Company
 180 S. Clinton Ave.
 Rochester, NY 14646

ACCESS SERVICE

5. Ordering Switched and Special Access Service (Cont'd)

5.1 Access Service Request Requirements (Cont'd)

5.1.3 Special Access Services

When placing an order for Special Access Services, the customer must provide the requirements as follows:

For all Special Access Services, the customer must specify the customer designated premises or Hubs involved, the type of service, (e.g., Voice Grade, High Capacity, etc.), the channel interface, technical specification package, and options desired. For multipoint services, the channel interface at each premises may, at the request of the customer, be different but all such interfaces shall be compatible.

5.1.4 Combined Access Service Arrangements

The Combined Access Service Arrangement optional feature, as set forth in Section 6 following, is ordered by a customer in the provision of that customer's intrastate communications service (e.g., WATS, 800, or WATS-type services) to end users. Orders for the Combined Access Service Arrangement must specify the required information as set forth preceding for the appropriate Switched Access Service Feature Group and Voice Grade Special Access Service. The customer must also specify the Combined Access Service Arrangement optional features, if any, the directionality of the service to be provided (i.e., originating, terminating, or two-way) and the type of Supervisory Signaling. (T)

If the wire center that serves the customer's end user premises is not capable of providing the necessary functions to combine Switched and Special Access Services as requested by the customer or is not a WATS Serving Office (WSO) the Telephone Company will configure the Special Access portion of the service to the nearest wire center where the necessary functions exist.

Continued

DATE ISSUED: May 9, 2012

EFFECTIVE DATE: July 1, 2012

Kenneth Mason
Vice President – Government & Regulatory Affairs
Citizens Communications Company
180 S. Clinton Ave.
Rochester, NY 14646

ACCESS SERVICE

5. Ordering Switched and Special Access Service (Cont'd)

5.1 Access Service Request Requirements (Cont'd)

5.1.5 Equal Access Conversions

When an office is scheduled to be converted to equal access, the IC must submit an Access Service Request for FGD service no later than 120 days prior to the end office equal access conversion date in order for the IC to participate in the presubscription process.

Customers may request existing FGA or FGB services be converted to FGD upon the conversion of an office to equal access. Changes in Feature Group types are provided as set forth in Section 6 following.

(T)

(A) Feature Group D Facilities Shortages

In the event a shortage of FGD resources exists, the Telephone Company will make every reasonable effort to meet all Access Service Requests as of the equal access conversion date. In the event these efforts are unsuccessful, the Telephone Company will notify all ICs requesting FGD service that a shortage of facilities exist and allocation of available facilities among participating ICs is necessary.

The available resources are determined by the Telephone Company and represent the equipment and facility quantities necessary to provide FGD service, excluding intraLATA FGC and interLATA FGC terminating resources currently in service. If the interLATA FGC trunks are arranged to carry two-way traffic, one half will be considered available resources.

FGD resources are allocated to each IC based on the percent of end users that are presubscribed to that IC as counted 30 days prior to the conversion date. For

Continued

DATE ISSUED: May 9, 2012

EFFECTIVE DATE: July 1, 2012

Kenneth Mason
Vice President – Government & Regulatory Affairs
Citizens Communications Company
180 S. Clinton Ave.
Rochester, NY 14646

ACCESS SERVICE

5. Ordering Switched and Special Access Service (Cont'd)

5.1 Access Service Request Requirements (Cont'd)

5.1.5 Equal Access Conversions (Cont'd)

(A) Feature Group D Facilities Shortages (Cont'd)

example, if 10% of end users in an end office scheduled to be converted to equal access are presubscribed to a particular IC, 10% of the total available FGD services will be allocated to that IC.

The quantity of resources in service for each IC as determined by the allocation process will be adjusted on the basis of actual usage and blocking measurements. Actual usage adjustments will be made 90 days after conversion to equal access. If necessary, this reallocation process will continue at three month intervals until all initial service requests have been met.

5.1.6 Provision of Other Services

(A) Testing Service, Additional Labor, Restoration Priority, and Special Facilities Routing shall be ordered with an Access Service Request or as set forth in (B) following. The rates and charges for these services, as set forth in other sections of this tariff, will apply in addition to the ordering charges set forth in this section and the rates and charges for the Access Service with which they are associated.

(B) Where possible, the Telephone Company will allow the services listed preceding to be subsequently added to an Access Service Request at any time, up to and including the service date for the Access Service. When added subsequently, charges for a design change as set forth in 5.3.1(C) following will apply when an engineering review is required.

ACCESS SERVICE

5. Ordering Switched and Special Access Service (Cont'd)5.1 Access Service Request Requirements (Cont'd)5.1.6 Provision of Other Services (Cont'd)

(C) Additional Engineering is not an ordering option, but will be applied to an Access Service Request when the Telephone Company determines that Additional Engineering is necessary to accommodate a customer request. Additional Engineering conditions and charges are as set forth in Section 8.1 following and are in addition to the regulations, rates and charges specified in this section.

5.1.7 Access Order Service Date Intervals

Access Service is provided with Service Date Intervals. The Service Date Interval is that period of time which the Telephone Company requires to properly provision the service and begins when the customer submits a completed Access Service Request for service, as set forth in 5.1 preceding. The Telephone Company shall publish and make available to all customers, upon reasonable request, a schedule of Service Date Intervals applicable for Switched and Special Access Services. The schedule shall specify the services and the quantities of services that can be provided in the Service Date Intervals. Service Date Interval schedules are provided during regular business days at Telephone Company offices at which the customer places an order for Access Service.

Access Services provided in a Service Date Interval will be installed during Telephone Company business days. If a customer requests that installation be done outside of scheduled work hours, and the Telephone Company agrees to this request, the customer will be subject to applicable Additional Labor Charges as set forth in Section 8.2 following.

** New or Revised**Continued*

DATE ISSUED: July 31, 2002

EFFECTIVE DATE: September 18, 2002

Aloa J. Stevens
Director – State Government Affairs
Citizens Communications Company
4 Triad Center, Suite 200
Salt Lake City, Utah 84180

ACCESS SERVICE

5. Ordering Switched and Special Access Service (Cont'd)

5.1 Access Service Request Requirements (Cont'd)

5.1.8 Selection of Facilities For Access Order

When there are analog or digital high capacity facilities to a Hub on order or in service for the customer's use, the customer may request a specific channel or transmission path be used to provide the Switched or Special Access Service requested in an Access Service Request. The Telephone Company will make a reasonable effort to accommodate the customer request.

For all other Access Service Requests, the option to request a specific transmission path or channel is not provided except as provided for under Special Facilities Routing as set forth in Section 11 following.

5.1.9 Shared Use Facilities

Shared Use (i.e., Switched and Special Access Services provided over the same analog or digital high capacity facilities) is allowed. Shared use facilities to a Hub will be ordered and provided as Special Access Service. While shared use is allowed, individual services utilizing these facilities must be ordered either as Switched Access Service or Special Access Service. When placing the order for the individual service(s), the customer must specify a channel assignment for each service ordered.

** New or Revised*

Continued

DATE ISSUED: July 31, 2002

EFFECTIVE DATE: September 18, 2002

Aloa J. Stevens
Director – State Government Affairs
Citizens Communications Company
4 Triad Center, Suite 200
Salt Lake City, Utah 84180

ACCESS SERVICE

5. Ordering Switched and Special Access Service (Cont'd)5.2 Access Services Provided by More than One Telephone Company

The Telephone Company will provide Access Services under this tariff where more than one Telephone Company is involved in the provision of Access Service as set forth in (A), (B), or (C) following. The Single Company Billing arrangement as set forth in (A) following will be used for FGA and FGB switched access services except where interconnection arrangements between the telephone companies involved permit the use of the Multiple Company Billing arrangement as set forth in (B) following. The Telephone Company will notify the customer of the billing arrangement when the customer orders FGA or FGB service. The Multiple Company Billing arrangement, as set forth in (B) following, will be used for all FGC, FGD, and 800 Access, Switched Access Services and Special Access Services.

(A) Single Company Billing

For FGA Switched Access Service the customer shall submit an ASR to the Telephone Company in whose territory the dial tone office is located. For FGB the customer shall submit an ASR to the Telephone Company in whose territory the end office switch or access tandem is located. The Telephone Company receiving the order from the customer will arrange to provide the service and bill the customer as set forth in Section 2.4.7(A) preceding.

For services ordered as set forth preceding, the customer shall provide a copy of the ASR containing all information as required in 5.1 preceding to any other Telephone Company involved in providing the service.

(B) Multiple Company Billing

For all Switched and Special Access Services, the customer shall submit an ASR to each Telephone Company involved in providing the service.

** New or Revised**Continued*

DATE ISSUED: July 31, 2002

EFFECTIVE DATE: September 18, 2002

Aloa J. Stevens
Director – State Government Affairs
Citizens Communications Company
4 Triad Center, Suite 200
Salt Lake City, Utah 84180

ACCESS SERVICE

5. Ordering Switched and Special Access Service (Cont'd)

5.2 Access Services Provided by More than One Telephone Company (Cont'd)

(B) Multiple Company Billing (Cont'd)

Each Telephone Company will provide the appropriate access service elements within its operating territory to a physical point of interconnection with the other involved telephone company(ies). The physical point of interconnection is the location where one telephone company's facilities connect with another telephone company's facilities.

Each telephone company that receives an order will bill the customer for the appropriate access service elements provided by each respective telephone company as set forth in Section 2.4.7(B) preceding.

(C) EAS and Access Tandem Arrangements

Where a customer utilizes FGA to originate and/or terminate calls within an Extended Area Service (EAS) calling area or FGB to originate and/or terminate calls within an access tandem network provided by more than one telephone company, as set forth in Section 2.4.7(C) preceding, the customer shall submit an ASR for FGA or FGB service in the manner set forth in (A) preceding. The customer shall also provide a copy of the ASR to any other telephone company involved in providing the service within the EAS calling area or access tandem network.

** New or Revised*

Continued

DATE ISSUED: July 31, 2002

EFFECTIVE DATE: September 18, 2002

Aloa J. Stevens
Director – State Government Affairs
Citizens Communications Company
4 Triad Center, Suite 200
Salt Lake City, Utah 84180

ACCESS SERVICE

5. Ordering Switched and Special Access Service (Cont'd)

5.3 Access Order Charges

5.3.1 Access Service Request Modifications

The customer may request a modification of its Access Service Request prior to the service date. The Telephone Company will make every effort to accommodate a requested modification when it is able to do so with the normal work force assigned to complete such an order within normal business hours. If the modification cannot be made with the normal work force during normal business hours, the Telephone Company will notify the customer. If the customer still desires the Access Service Request modification, the Telephone Company will schedule a new service date. All charges for Access Service Request modifications will apply on a per occurrence basis.

Any increase in the number of Special Access circuits or Switched Access Service lines, trunks, or busy hour minutes of capacity will be treated as a new Access Service Request (for the increased amount only).

If order modifications are necessary to satisfy the transmission performance for a Special Access Service ordered by a customer, these changes will be made without order modification charges being incurred by the customer.

(A) Service Date Change Charge

Access Order service dates may be changed, but the new service date may not exceed the original service date by more than 30 calendar days. If the customer is unable to accept the service on the established service date and/or the customer requested service date is more than 30 calendar days after the original service date, the customer will have the option of (a) or (b) following:

ACCESS SERVICE

5. Ordering Switched and Special Access Service (Cont'd)5.3 Access Order Charges (Cont'd)5.3.1 Access Service Request Modifications (Cont'd)(A) Service Date Change Charge (Cont'd)

- (a) The original order will be cancelled by the Telephone Company, and reissued with appropriate cancellation charges applied, or
- (b) the billing will commence for the services ordered on the original ASR.

If the Telephone company determines it can accommodate the customer's request without delaying service dates for orders of other customers, a new service date may be established that is prior to the original standard or negotiated interval service date.

If the service date is changed to an earlier date, and the Telephone Company determines additional labor or extraordinary costs are necessary to meet the earlier service date requested by the customer, the customer will be notified by the Telephone Company that Expedited Order Charges as set forth in (D) following apply. Such charges will apply in addition to the Service Date Change Charge.

A Service Date Change Charge will apply, on a per order per occurrence basis, for each service date changed. The applicable charge is:

	<u>CHARGE</u>
Service Date Change Charge, per order	\$27.00

* *New or Revised**Continued*

DATE ISSUED: July 31, 2002

EFFECTIVE DATE: September 18, 2002

Aloa J. Stevens
Director – State Government Affairs
Citizens Communications Company
4 Triad Center, Suite 200
Salt Lake City, Utah 84180

ACCESS SERVICE

5. Ordering Switched and Special Access Service (Cont'd)

5.3 Access Order Charges (Cont'd)

5.3.1 Access Service Request Modifications (Cont'd)

(B) Partial Cancellation Charge

Any decrease in the number of ordered Special Access Service circuits or Switched Access Service lines, trunks or busy hour minutes of capacity will be treated as a partial cancellation and the charges as set forth in 5.3.2(C) following will apply.

(C) Design Change Charge

The customer may request a design change to the service ordered. A design change is any change to an Access Service Request which requires engineering review. An engineering review is a review by Telephone Company personnel of the service ordered and the requested changes to determine what changes in the design, if any, are necessary to meet the changes requested by the customer. Design changes include such things as the addition or deletion of optional features or functions or a change in the type of Transport Termination (Switched Access only), type of channel interface, type of Interface Group or technical specification package. Design changes do not include a change of customer premises, end user premises, end office switch, Feature Group type, or Special Access Service circuit type. Changes of this nature will require the issuance of a new order and the cancellation of the original order with appropriate cancellation charges applied.

The Telephone Company will review the requested change, notify the customer whether the change is a design change, if it can be accommodated and if a new

** New or Revised*

Continued

DATE ISSUED: July 31, 2002

EFFECTIVE DATE: September 18, 2002

Aloa J. Stevens
Director – State Government Affairs
Citizens Communications Company
4 Triad Center, Suite 200
Salt Lake City, Utah 84180

ACCESS SERVICE

5. Ordering Switched and Special Access Service (Cont'd)5.3 Access Order Charges (Cont'd)5.3.1 Access Service Request Modifications (Cont'd)(C) Design Change Charge (Cont'd)

service date is required. If the customer authorizes the Telephone Company to proceed with the design change, a Design Change Charge will apply. The Design Change Charge will apply on a per order per occurrence basis, for each order requiring a design change. The applicable charge is:

	<u>Rate</u>
Design Change Charge, per order	H28 \$27.00

If a change of service date is required, the Service Date Change Charge as set forth in (A) preceding will also apply.

(D) Expedited Order Charge

When placing an Access Service Request a customer may request a service date that is prior to the Telephone Company's published service date interval. A customer may also request an earlier service date on a pending Access Service Request. If the Telephone Company determines that service can be provided on the requested date and that additional labor cost or extraordinary costs are required to meet the requested service date, the customer will be notified and will be provided with an estimate of the additional charges involved. Actual charges assessed may not exceed the estimate by more than 10%. Such additional charges will be determined and billed to the customer as following:

ACCESS SERVICE

5. Ordering Switched and Special Access Service (Cont'd)

5.3 Access Order Charges (Cont'd)

5.3.1 Access Service Request Modifications (Cont'd)

(D) Expedited Order Charge (Cont'd)

To calculate the additional labor charges, the Telephone Company will, upon authorization from the customer to incur the additional labor charges, keep track of the additional labor hours used to meet the request of the customer and will bill the customer at the applicable Additional Labor charges as set forth below.

When the request for expediting occurs subsequent to the issuance of the Access Service Request, a Service Date Change Charge as set forth in (A) preceding also applies.

5.3.2 Cancellation of an Access Service Request

A customer may cancel an Access Service Request on any date after receipt of the Access Service Request by the Telephone Company and prior to the installation of service. The cancellation date is the date the Telephone Company receives written or verbal notice from the customer that the Access Service Request order is to be cancelled. The verbal notice must be followed by written confirmation within 10 days. If written confirmation of the cancellation is not received by the Telephone Company, the verbal notice will not

ACCESS SERVICE

5. Ordering Switched and Special Access Service (Cont'd)

5.3 Access Order Charges (Cont'd)

5.3.2 Cancellation of an Access Service Request (Cont'd)

be considered a valid cancellation notice. When a customer cancels an Access Service Request for the discontinuance of service, no charges apply for the cancellation.

(A) Delay of Service Date by Customer

If a customer or a customer's end user is unable to accept Access Service within 30 calendar days after the original service date, the customer has the choice of the following options:

- The Access Service Request shall be cancelled and charges set forth in (C) following will apply, or
- Billing for the service will commence.

In such instances, the cancellation date or the billing date, depending on which option is selected by the customer, shall be the 31st day beyond the original service date of the Access Service Request.

(B) Delay of Service Date by Telephone Company

If the Telephone Company misses a service date by more than 30 days due to circumstances over which it has direct control (excluding, e.g., Acts of God, governmental requirements, work stoppages, and civil commotions), the customer may cancel the Access Service Request without incurring cancellation charges.

ACCESS SERVICE

5. Ordering Switched and Special Access Service (Cont'd)

5.3 Access Order Charges (Cont'd)

5.3.2 Cancellation of an Access Service Request (Cont'd)

(C) Cancellation Charge

When a customer cancels an Access Service Request and the Telephone Company incurs any costs associated with the processing of the Access Service Request or installation prior to the cancellation date, the Cancellation Charge will apply. The Cancellation Charge specified in (1) or (2) following, whichever is lower, shall apply.

- (1) The charge for the minimum period of Switched or Special Access Service as set forth in 5.3.3 following.
- (2) A charge equal to the costs incurred in such installation, less estimated net salvage, and/or a charge equal to the costs incurred in such order processing. These charges include the nonrecoverable cost of installation and removal including the costs of engineering, labor, supervision, transportation, right-of-way, and other associated costs.

Installation and Order costs of Switched or Special Access Service facilities are considered to have started when the Telephone incurs any costs associated with such installation or order processing.

5.3.3 Minimum Period Charges

- (A) When Access Service is disconnected prior to the expiration of the minimum period, charges are applicable for the balance of the minimum period. A disconnect constitutes facilities being returned to available inventory.

** New or Revised*

Continued

DATE ISSUED: July 31, 2002

EFFECTIVE DATE: September 18, 2002

Aloa J. Stevens
Director – State Government Affairs
Citizens Communications Company
4 Triad Center, Suite 200
Salt Lake City, Utah 84180

ACCESS SERVICE

5. Ordering Switched and Special Access Service (Cont'd)

5.3 Access Order Charges (Cont'd)

5.3.3 Minimum Period Charges (Cont'd)

(A) (Cont'd)

For purposes of applying minimum period charges, the disconnect date shall be two business days after the date the Telephone Company receives written notification from the customer or the date the customer requests service be disconnected, whichever is the later date.

(B) The Minimum Period Charge for monthly billed services will be determined as follows:

For Switched Access Service, the charge for a month or fraction thereof is equal to the applicable minimum monthly charge for the capacity as set forth in Section 6 following.

(T)

For Special Access Service, the charge for a month or fraction thereof is the applicable monthly rates for the service as set forth in Section 7.2.3 following.

The Minimum Period Charge for part-time Television and Program Audio Services is the applicable daily rate for the service as set forth in Section 7.2.3 following.

Continued

DATE ISSUED: May 9, 2012

EFFECTIVE DATE: July 1, 2012

Kenneth Mason
Vice President – Government & Regulatory Affairs
Citizens Communications Company
180 S. Clinton Ave.
Rochester, NY 14646

ACCESS SERVICE

6. Switched Access Service

6.1 General

The Telephone Company adopts Section 6 and the associated rates in Section 20 of Frontier Telephone Companies Tariff FCC No. 1 (the Telephone Company's Interstate Access Tariff) effective as of July 1, 2012, and any successive issues thereto. This tariff was filed with the FCC on behalf of the Telephone Company and affiliated companies.

(N)

This tariff includes all the rules, regulations, rates and charges under which interstate access services will be offered. Exceptions to this adoption of the tariff schedules, if any, are as follows and in Section 16.2.

6.2 Language Exceptions

(None)

(N)

(D)

(D)

Continued

DATE ISSUED: May 9, 2012

EFFECTIVE DATE: July 1, 2012

Kenneth Mason
Vice President – Government & Regulatory Affairs
Citizens Communications Company
180 S. Clinton Ave.
Rochester, NY 14646

ACCESS SERVICE

6. Reserved For Future Use

(T)

(D)

(D)

Continued

DATE ISSUED: May 9, 2012

EFFECTIVE DATE: July 1, 2012

Kenneth Mason
Vice President – Government & Regulatory Affairs
Citizens Communications Company
180 S. Clinton Ave.
Rochester, NY 14646

ACCESS SERVICE

6. Reserved For Future Use

(T)

(D)

(D)

Continued

DATE ISSUED: May 9, 2012

EFFECTIVE DATE: July 1, 2012

Kenneth Mason
Vice President – Government & Regulatory Affairs
Citizens Communications Company
180 S. Clinton Ave.
Rochester, NY 14646

ACCESS SERVICE

6. Reserved For Future Use

(T)

(D)

(D)

Continued

DATE ISSUED: May 9, 2012

EFFECTIVE DATE: July 1, 2012

Kenneth Mason
Vice President – Government & Regulatory Affairs
Citizens Communications Company
180 S. Clinton Ave.
Rochester, NY 14646

ACCESS SERVICE

6. Reserved For Future Use

(T)

(D)

(D)

Continued

DATE ISSUED: May 9, 2012

EFFECTIVE DATE: July 1, 2012

Kenneth Mason
Vice President – Government & Regulatory Affairs
Citizens Communications Company
180 S. Clinton Ave.
Rochester, NY 14646

ACCESS SERVICE

6. Reserved For Future Use

(T)

(D)

(D)

Continued

DATE ISSUED: May 9, 2012

EFFECTIVE DATE: July 1, 2012

Kenneth Mason
Vice President – Government & Regulatory Affairs
Citizens Communications Company
180 S. Clinton Ave.
Rochester, NY 14646

ACCESS SERVICE

6. Reserved For Future Use

(T)

(D)

(D)

Continued

DATE ISSUED: May 9, 2012

EFFECTIVE DATE: July 1, 2012

Kenneth Mason
Vice President – Government & Regulatory Affairs
Citizens Communications Company
180 S. Clinton Ave.
Rochester, NY 14646

ACCESS SERVICE

6. Reserved For Future Use

(T)

(D)

(D)

Continued

DATE ISSUED: May 9, 2012

EFFECTIVE DATE: July 1, 2012

Kenneth Mason
Vice President – Government & Regulatory Affairs
Citizens Communications Company
180 S. Clinton Ave.
Rochester, NY 14646

ACCESS SERVICE

6. Reserved For Future Use

(T)

(D)

(D)

Continued

DATE ISSUED: May 9, 2012

EFFECTIVE DATE: July 1, 2012

Kenneth Mason
Vice President – Government & Regulatory Affairs
Citizens Communications Company
180 S. Clinton Ave.
Rochester, NY 14646

ACCESS SERVICE

6. Reserved For Future Use

(T)

(D)

(D)

Continued

DATE ISSUED: May 9, 2012

EFFECTIVE DATE: July 1, 2012

Kenneth Mason
Vice President – Government & Regulatory Affairs
Citizens Communications Company
180 S. Clinton Ave.
Rochester, NY 14646

ACCESS SERVICE

6. Reserved For Future Use

(T)

(D)

(D)

Continued

DATE ISSUED: May 9, 2012

EFFECTIVE DATE: July 1, 2012

Kenneth Mason
Vice President – Government & Regulatory Affairs
Citizens Communications Company
180 S. Clinton Ave.
Rochester, NY 14646

ACCESS SERVICE

6. Reserved For Future Use

(T)

(D)

(D)

Continued

DATE ISSUED: May 9, 2012

EFFECTIVE DATE: July 1, 2012

Kenneth Mason
Vice President – Government & Regulatory Affairs
Citizens Communications Company
180 S. Clinton Ave.
Rochester, NY 14646

ACCESS SERVICE

6. Reserved For Future Use

(T)

(D)

(D)

Continued

DATE ISSUED: May 9, 2012

EFFECTIVE DATE: July 1, 2012

Kenneth Mason
Vice President – Government & Regulatory Affairs
Citizens Communications Company
180 S. Clinton Ave.
Rochester, NY 14646

ACCESS SERVICE

6. Reserved For Future Use

(T)

(D)

(D)

Continued

DATE ISSUED: May 9, 2012

EFFECTIVE DATE: July 1, 2012

Kenneth Mason
Vice President – Government & Regulatory Affairs
Citizens Communications Company
180 S. Clinton Ave.
Rochester, NY 14646

ACCESS SERVICE

6. Reserved For Future Use

(T)

(D)

(D)

Continued

DATE ISSUED: May 9, 2012

EFFECTIVE DATE: July 1, 2012

Kenneth Mason
Vice President – Government & Regulatory Affairs
Citizens Communications Company
180 S. Clinton Ave.
Rochester, NY 14646

ACCESS SERVICE

6. Reserved For Future Use

(T)

(D)

(D)

Continued

DATE ISSUED: May 9, 2012

EFFECTIVE DATE: July 1, 2012

Kenneth Mason
Vice President – Government & Regulatory Affairs
Citizens Communications Company
180 S. Clinton Ave.
Rochester, NY 14646

ACCESS SERVICE

6. Reserved For Future Use

(T)

(D)

(D)

Continued

DATE ISSUED: May 9, 2012

EFFECTIVE DATE: July 1, 2012

Kenneth Mason
Vice President – Government & Regulatory Affairs
Citizens Communications Company
180 S. Clinton Ave.
Rochester, NY 14646

ACCESS SERVICE

6. Reserved For Future Use

(T)

(D)

(D)

Continued

DATE ISSUED: May 9, 2012

EFFECTIVE DATE: July 1, 2012

Kenneth Mason
Vice President – Government & Regulatory Affairs
Citizens Communications Company
180 S. Clinton Ave.
Rochester, NY 14646

ACCESS SERVICE

6. Reserved For Future Use

(T)

(D)

(D)

Continued

DATE ISSUED: May 9, 2012

EFFECTIVE DATE: July 1, 2012

Kenneth Mason
Vice President – Government & Regulatory Affairs
Citizens Communications Company
180 S. Clinton Ave.
Rochester, NY 14646

ACCESS SERVICE

6. Reserved For Future Use

(T)

(D)

(D)

Continued

DATE ISSUED: May 9, 2012

EFFECTIVE DATE: July 1, 2012

Kenneth Mason
Vice President – Government & Regulatory Affairs
Citizens Communications Company
180 S. Clinton Ave.
Rochester, NY 14646

ACCESS SERVICE

6. Reserved For Future Use

(T)

(D)

(D)

Continued

DATE ISSUED: May 9, 2012

EFFECTIVE DATE: July 1, 2012

Kenneth Mason
Vice President – Government & Regulatory Affairs
Citizens Communications Company
180 S. Clinton Ave.
Rochester, NY 14646

ACCESS SERVICE

6. Reserved For Future Use

(T)

(D)

(D)

Continued

DATE ISSUED: May 9, 2012

EFFECTIVE DATE: July 1, 2012

Kenneth Mason
Vice President – Government & Regulatory Affairs
Citizens Communications Company
180 S. Clinton Ave.
Rochester, NY 14646

ACCESS SERVICE

6. Reserved For Future Use

(T)

(D)

(D)

Continued

DATE ISSUED: May 9, 2012

EFFECTIVE DATE: July 1, 2012

Kenneth Mason
Vice President – Government & Regulatory Affairs
Citizens Communications Company
180 S. Clinton Ave.
Rochester, NY 14646

ACCESS SERVICE

6. Reserved For Future Use

(T)

(D)

(D)

Continued

DATE ISSUED: May 9, 2012

EFFECTIVE DATE: July 1, 2012

Kenneth Mason
Vice President – Government & Regulatory Affairs
Citizens Communications Company
180 S. Clinton Ave.
Rochester, NY 14646

ACCESS SERVICE

6. Reserved For Future Use

(T)

(D)

(D)

Continued

DATE ISSUED: May 9, 2012

EFFECTIVE DATE: July 1, 2012

Kenneth Mason
Vice President – Government & Regulatory Affairs
Citizens Communications Company
180 S. Clinton Ave.
Rochester, NY 14646

ACCESS SERVICE

6. Reserved For Future Use

(T)

(D)

(D)

Continued

DATE ISSUED: May 9, 2012

EFFECTIVE DATE: July 1, 2012

Kenneth Mason
Vice President – Government & Regulatory Affairs
Citizens Communications Company
180 S. Clinton Ave.
Rochester, NY 14646

ACCESS SERVICE

6. Reserved For Future Use

(T)

(D)

(D)

Continued

DATE ISSUED: May 9, 2012

EFFECTIVE DATE: July 1, 2012

Kenneth Mason
Vice President – Government & Regulatory Affairs
Citizens Communications Company
180 S. Clinton Ave.
Rochester, NY 14646

ACCESS SERVICE

6. Reserved For Future Use

(T)

(D)

(D)

Continued

DATE ISSUED: May 9, 2012

EFFECTIVE DATE: July 1, 2012

Kenneth Mason
Vice President – Government & Regulatory Affairs
Citizens Communications Company
180 S. Clinton Ave.
Rochester, NY 14646

ACCESS SERVICE

6. Reserved For Future Use

(T)

(D)

(D)

Continued

DATE ISSUED: May 9, 2012

EFFECTIVE DATE: July 1, 2012

Kenneth Mason
Vice President – Government & Regulatory Affairs
Citizens Communications Company
180 S. Clinton Ave.
Rochester, NY 14646

ACCESS SERVICE

6. Reserved For Future Use

(T)

(D)

(D)

Continued

DATE ISSUED: May 9, 2012

EFFECTIVE DATE: July 1, 2012

Kenneth Mason
Vice President – Government & Regulatory Affairs
Citizens Communications Company
180 S. Clinton Ave.
Rochester, NY 14646

ACCESS SERVICE

6. Reserved For Future Use

(T)

(D)

(D)

Continued

DATE ISSUED: May 9, 2012

EFFECTIVE DATE: July 1, 2012

Kenneth Mason
Vice President – Government & Regulatory Affairs
Citizens Communications Company
180 S. Clinton Ave.
Rochester, NY 14646

ACCESS SERVICE

6. Reserved For Future Use

(T)

(D)

(D)

Continued

DATE ISSUED: May 9, 2012

EFFECTIVE DATE: July 1, 2012

Kenneth Mason
Vice President – Government & Regulatory Affairs
Citizens Communications Company
180 S. Clinton Ave.
Rochester, NY 14646

ACCESS SERVICE

6. Reserved For Future Use

(T)

(D)

(D)

Continued

DATE ISSUED: May 9, 2012

EFFECTIVE DATE: July 1, 2012

Kenneth Mason
Vice President – Government & Regulatory Affairs
Citizens Communications Company
180 S. Clinton Ave.
Rochester, NY 14646

ACCESS SERVICE

6. Reserved For Future Use

(T)

(D)

(D)

Continued

DATE ISSUED: May 9, 2012

EFFECTIVE DATE: July 1, 2012

Kenneth Mason
Vice President – Government & Regulatory Affairs
Citizens Communications Company
180 S. Clinton Ave.
Rochester, NY 14646

ACCESS SERVICE

6. Reserved For Future Use

(T)

(D)

(D)

Continued

DATE ISSUED: May 9, 2012

EFFECTIVE DATE: July 1, 2012

Kenneth Mason
Vice President – Government & Regulatory Affairs
Citizens Communications Company
180 S. Clinton Ave.
Rochester, NY 14646

ACCESS SERVICE

6. Reserved For Future Use

(T)

(D)

(D)

Continued

DATE ISSUED: May 9, 2012

EFFECTIVE DATE: July 1, 2012

Kenneth Mason
Vice President – Government & Regulatory Affairs
Citizens Communications Company
180 S. Clinton Ave.
Rochester, NY 14646

ACCESS SERVICE

6. Reserved For Future Use

(T)

(D)

(D)

Continued

DATE ISSUED: May 9, 2012

EFFECTIVE DATE: July 1, 2012

Kenneth Mason
Vice President – Government & Regulatory Affairs
Citizens Communications Company
180 S. Clinton Ave.
Rochester, NY 14646

ACCESS SERVICE

6. Reserved For Future Use

(T)

(D)

(D)

Continued

DATE ISSUED: May 9, 2012

EFFECTIVE DATE: July 1, 2012

Kenneth Mason
Vice President – Government & Regulatory Affairs
Citizens Communications Company
180 S. Clinton Ave.
Rochester, NY 14646

ACCESS SERVICE

6. Reserved For Future Use

(T)

(D)

(D)

Continued

DATE ISSUED: May 9, 2012

EFFECTIVE DATE: July 1, 2012

Kenneth Mason
Vice President – Government & Regulatory Affairs
Citizens Communications Company
180 S. Clinton Ave.
Rochester, NY 14646

ACCESS SERVICE

6. Reserved For Future Use

(T)

(D)

(D)

Continued

DATE ISSUED: May 9, 2012

EFFECTIVE DATE: July 1, 2012

Kenneth Mason
Vice President – Government & Regulatory Affairs
Citizens Communications Company
180 S. Clinton Ave.
Rochester, NY 14646

ACCESS SERVICE

6. Reserved For Future Use

(T)

(D)

(D)

Continued

DATE ISSUED: May 9, 2012

EFFECTIVE DATE: July 1, 2012

Kenneth Mason
Vice President – Government & Regulatory Affairs
Citizens Communications Company
180 S. Clinton Ave.
Rochester, NY 14646

ACCESS SERVICE

6. Reserved For Future Use

(T)

(D)

(D)

Continued

DATE ISSUED: May 9, 2012

EFFECTIVE DATE: July 1, 2012

Kenneth Mason
Vice President – Government & Regulatory Affairs
Citizens Communications Company
180 S. Clinton Ave.
Rochester, NY 14646

ACCESS SERVICE

6. Reserved For Future Use

(T)

(D)

(D)

Continued

DATE ISSUED: May 9, 2012

EFFECTIVE DATE: July 1, 2012

Kenneth Mason
Vice President – Government & Regulatory Affairs
Citizens Communications Company
180 S. Clinton Ave.
Rochester, NY 14646

ACCESS SERVICE

6. Reserved For Future Use

(T)

(D)

(D)

Continued

DATE ISSUED: May 9, 2012

EFFECTIVE DATE: July 1, 2012

Kenneth Mason
Vice President – Government & Regulatory Affairs
Citizens Communications Company
180 S. Clinton Ave.
Rochester, NY 14646

ACCESS SERVICE

6. Reserved For Future Use

(T)

(D)

(D)

Continued

DATE ISSUED: May 9, 2012

EFFECTIVE DATE: July 1, 2012

Kenneth Mason
Vice President – Government & Regulatory Affairs
Citizens Communications Company
180 S. Clinton Ave.
Rochester, NY 14646

ACCESS SERVICE

6. Reserved For Future Use

(T)

(D)

(D)

Continued

DATE ISSUED: May 9, 2012

EFFECTIVE DATE: July 1, 2012

Kenneth Mason
Vice President – Government & Regulatory Affairs
Citizens Communications Company
180 S. Clinton Ave.
Rochester, NY 14646

ACCESS SERVICE

6. Reserved For Future Use

(T)

(D)

(D)

Continued

DATE ISSUED: May 9, 2012

EFFECTIVE DATE: July 1, 2012

Kenneth Mason
Vice President – Government & Regulatory Affairs
Citizens Communications Company
180 S. Clinton Ave.
Rochester, NY 14646

ACCESS SERVICE

6. Reserved For Future Use

(T)

(D)

(D)

Continued

DATE ISSUED: May 9, 2012

EFFECTIVE DATE: July 1, 2012

Kenneth Mason
Vice President – Government & Regulatory Affairs
Citizens Communications Company
180 S. Clinton Ave.
Rochester, NY 14646

ACCESS SERVICE

6. Reserved For Future Use

(T)

(D)

(D)

Continued

DATE ISSUED: May 9, 2012

EFFECTIVE DATE: July 1, 2012

Kenneth Mason
Vice President – Government & Regulatory Affairs
Citizens Communications Company
180 S. Clinton Ave.
Rochester, NY 14646

ACCESS SERVICE

6. Reserved For Future Use

(T)

(D)

(D)

Continued

DATE ISSUED: May 9, 2012

EFFECTIVE DATE: July 1, 2012

Kenneth Mason
Vice President – Government & Regulatory Affairs
Citizens Communications Company
180 S. Clinton Ave.
Rochester, NY 14646

ACCESS SERVICE

6. Reserved For Future Use

(T)

(D)

(D)

Continued

DATE ISSUED: May 9, 2012

EFFECTIVE DATE: July 1, 2012

Kenneth Mason
Vice President – Government & Regulatory Affairs
Citizens Communications Company
180 S. Clinton Ave.
Rochester, NY 14646

ACCESS SERVICE

6. Reserved For Future Use

(T)

(D)

(D)

Continued

DATE ISSUED: May 9, 2012

EFFECTIVE DATE: July 1, 2012

Kenneth Mason
Vice President – Government & Regulatory Affairs
Citizens Communications Company
180 S. Clinton Ave.
Rochester, NY 14646

ACCESS SERVICE

6. Reserved For Future Use

(T)

(D)

(D)

Continued

DATE ISSUED: May 9, 2012

EFFECTIVE DATE: July 1, 2012

Kenneth Mason
Vice President – Government & Regulatory Affairs
Citizens Communications Company
180 S. Clinton Ave.
Rochester, NY 14646

ACCESS SERVICE

6. Reserved For Future Use

(T)

(D)

(D)

Continued

DATE ISSUED: May 9, 2012

EFFECTIVE DATE: July 1, 2012

Kenneth Mason
Vice President – Government & Regulatory Affairs
Citizens Communications Company
180 S. Clinton Ave.
Rochester, NY 14646

ACCESS SERVICE

6. Reserved For Future Use

(T)

(D)

(D)

Continued

DATE ISSUED: May 9, 2012

EFFECTIVE DATE: July 1, 2012

Kenneth Mason
Vice President – Government & Regulatory Affairs
Citizens Communications Company
180 S. Clinton Ave.
Rochester, NY 14646

ACCESS SERVICE

6. Reserved For Future Use

(T)

(D)

(D)

Continued

DATE ISSUED: May 9, 2012

EFFECTIVE DATE: July 1, 2012

Kenneth Mason
Vice President – Government & Regulatory Affairs
Citizens Communications Company
180 S. Clinton Ave.
Rochester, NY 14646

ACCESS SERVICE

6. Reserved For Future Use

(T)

(D)

(D)

Continued

DATE ISSUED: May 9, 2012

EFFECTIVE DATE: July 1, 2012

Kenneth Mason
Vice President – Government & Regulatory Affairs
Citizens Communications Company
180 S. Clinton Ave.
Rochester, NY 14646

ACCESS SERVICE

6. Reserved For Future Use

(T)

(D)

(D)

Continued

DATE ISSUED: May 9, 2012

EFFECTIVE DATE: July 1, 2012

Kenneth Mason
Vice President – Government & Regulatory Affairs
Citizens Communications Company
180 S. Clinton Ave.
Rochester, NY 14646

ACCESS SERVICE

6. Reserved For Future Use

(T)

(D)

(D)

Continued

DATE ISSUED: May 9, 2012

EFFECTIVE DATE: July 1, 2012

Kenneth Mason
Vice President – Government & Regulatory Affairs
Citizens Communications Company
180 S. Clinton Ave.
Rochester, NY 14646

ACCESS SERVICE

6. Reserved For Future Use

(T)

(D)

(D)

Continued

DATE ISSUED: May 9, 2012

EFFECTIVE DATE: July 1, 2012

Kenneth Mason
Vice President – Government & Regulatory Affairs
Citizens Communications Company
180 S. Clinton Ave.
Rochester, NY 14646

ACCESS SERVICE

6. Reserved For Future Use

(T)

(D)

(D)

Continued

DATE ISSUED: May 9, 2012

EFFECTIVE DATE: July 1, 2012

Kenneth Mason
Vice President – Government & Regulatory Affairs
Citizens Communications Company
180 S. Clinton Ave.
Rochester, NY 14646

ACCESS SERVICE

6. Reserved For Future Use

(T)

(D)

(D)

Continued

DATE ISSUED: May 9, 2012

EFFECTIVE DATE: July 1, 2012

Kenneth Mason
Vice President – Government & Regulatory Affairs
Citizens Communications Company
180 S. Clinton Ave.
Rochester, NY 14646

ACCESS SERVICE

6. Reserved For Future Use

(T)

(D)

(D)

Continued

DATE ISSUED: May 9, 2012

EFFECTIVE DATE: July 1, 2012

Kenneth Mason
Vice President – Government & Regulatory Affairs
Citizens Communications Company
180 S. Clinton Ave.
Rochester, NY 14646

ACCESS SERVICE

6. Reserved For Future Use

(T)

(D)

(D)

Continued

DATE ISSUED: May 9, 2012

EFFECTIVE DATE: July 1, 2012

Kenneth Mason
Vice President – Government & Regulatory Affairs
Citizens Communications Company
180 S. Clinton Ave.
Rochester, NY 14646

ACCESS SERVICE

6. Reserved For Future Use

(T)

(D)

(D)

Continued

DATE ISSUED: May 9, 2012

EFFECTIVE DATE: July 1, 2012

Kenneth Mason
Vice President – Government & Regulatory Affairs
Citizens Communications Company
180 S. Clinton Ave.
Rochester, NY 14646

ACCESS SERVICE

6. Reserved For Future Use

(T)

(D)

(D)

Continued

DATE ISSUED: May 9, 2012

EFFECTIVE DATE: July 1, 2012

Kenneth Mason
Vice President – Government & Regulatory Affairs
Citizens Communications Company
180 S. Clinton Ave.
Rochester, NY 14646

ACCESS SERVICE

6. Reserved For Future Use

(T)

(D)

(D)

Continued

DATE ISSUED: May 9, 2012

EFFECTIVE DATE: July 1, 2012

Kenneth Mason
Vice President – Government & Regulatory Affairs
Citizens Communications Company
180 S. Clinton Ave.
Rochester, NY 14646

ACCESS SERVICE

6. Reserved For Future Use

(T)

(D)

(D)

Continued

DATE ISSUED: May 9, 2012

EFFECTIVE DATE: July 1, 2012

Kenneth Mason
Vice President – Government & Regulatory Affairs
Citizens Communications Company
180 S. Clinton Ave.
Rochester, NY 14646

ACCESS SERVICE

6. Reserved For Future Use

(T)

(D)

(D)

Continued

DATE ISSUED: May 9, 2012

EFFECTIVE DATE: July 1, 2012

Kenneth Mason
Vice President – Government & Regulatory Affairs
Citizens Communications Company
180 S. Clinton Ave.
Rochester, NY 14646

ACCESS SERVICE

6. Reserved For Future Use

(T)

(D)

(D)

Continued

DATE ISSUED: May 9, 2012

EFFECTIVE DATE: July 1, 2012

Kenneth Mason
Vice President – Government & Regulatory Affairs
Citizens Communications Company
180 S. Clinton Ave.
Rochester, NY 14646

ACCESS SERVICE

6. Reserved For Future Use

(T)

(D)

(D)

Continued

DATE ISSUED: May 9, 2012

EFFECTIVE DATE: July 1, 2012

Kenneth Mason
Vice President – Government & Regulatory Affairs
Citizens Communications Company
180 S. Clinton Ave.
Rochester, NY 14646

ACCESS SERVICE

6. Reserved For Future Use

(T)

(D)

(D)

Continued

DATE ISSUED: May 9, 2012

EFFECTIVE DATE: July 1, 2012

Kenneth Mason
Vice President – Government & Regulatory Affairs
Citizens Communications Company
180 S. Clinton Ave.
Rochester, NY 14646

ACCESS SERVICE

6. Reserved For Future Use

(T)

(D)

(D)

Continued

DATE ISSUED: May 9, 2012

EFFECTIVE DATE: July 1, 2012

Kenneth Mason
Vice President – Government & Regulatory Affairs
Citizens Communications Company
180 S. Clinton Ave.
Rochester, NY 14646

ACCESS SERVICE

6. Reserved For Future Use

(T)

(D)

(D)

Continued

DATE ISSUED: May 9, 2012

EFFECTIVE DATE: July 1, 2012

Kenneth Mason
Vice President – Government & Regulatory Affairs
Citizens Communications Company
180 S. Clinton Ave.
Rochester, NY 14646

ACCESS SERVICE

6. Reserved For Future Use

(T)

(D)

(D)

Continued

DATE ISSUED: May 9, 2012

EFFECTIVE DATE: July 1, 2012

Kenneth Mason
Vice President – Government & Regulatory Affairs
Citizens Communications Company
180 S. Clinton Ave.
Rochester, NY 14646

ACCESS SERVICE

6. Reserved For Future Use

(T)

(D)

(D)

Continued

DATE ISSUED: May 9, 2012

EFFECTIVE DATE: July 1, 2012

Kenneth Mason
Vice President – Government & Regulatory Affairs
Citizens Communications Company
180 S. Clinton Ave.
Rochester, NY 14646

ACCESS SERVICE

6. Reserved For Future Use

(T)

(D)

(D)

Continued

DATE ISSUED: May 9, 2012

EFFECTIVE DATE: July 1, 2012

Kenneth Mason
Vice President – Government & Regulatory Affairs
Citizens Communications Company
180 S. Clinton Ave.
Rochester, NY 14646

ACCESS SERVICE

6. Reserved For Future Use

(T)

(D)

(D)

Continued

DATE ISSUED: May 9, 2012

EFFECTIVE DATE: July 1, 2012

Kenneth Mason
Vice President – Government & Regulatory Affairs
Citizens Communications Company
180 S. Clinton Ave.
Rochester, NY 14646

ACCESS SERVICE

6. Reserved For Future Use

(T)

(D)

(D)

Continued

DATE ISSUED: May 9, 2012

EFFECTIVE DATE: July 1, 2012

Kenneth Mason
Vice President – Government & Regulatory Affairs
Citizens Communications Company
180 S. Clinton Ave.
Rochester, NY 14646

ACCESS SERVICE

6. Reserved For Future Use

(T)

(D)

(D)

Continued

DATE ISSUED: May 9, 2012

EFFECTIVE DATE: July 1, 2012

Kenneth Mason
Vice President – Government & Regulatory Affairs
Citizens Communications Company
180 S. Clinton Ave.
Rochester, NY 14646

ACCESS SERVICE

6. Reserved For Future Use

(T)

(D)

(D)

Continued

DATE ISSUED: May 9, 2012

EFFECTIVE DATE: July 1, 2012

Kenneth Mason
Vice President – Government & Regulatory Affairs
Citizens Communications Company
180 S. Clinton Ave.
Rochester, NY 14646

ACCESS SERVICE

6. Reserved For Future Use

(T)

(D)

(D)

Continued

DATE ISSUED: May 9, 2012

EFFECTIVE DATE: July 1, 2012

Kenneth Mason
Vice President – Government & Regulatory Affairs
Citizens Communications Company
180 S. Clinton Ave.
Rochester, NY 14646

ACCESS SERVICE

6. Reserved For Future Use

(T)

(D)

(D)

Continued

DATE ISSUED: May 9, 2012

EFFECTIVE DATE: July 1, 2012

Kenneth Mason
Vice President – Government & Regulatory Affairs
Citizens Communications Company
180 S. Clinton Ave.
Rochester, NY 14646

ACCESS SERVICE

6. Reserved For Future Use

(T)

(D)

(D)

Continued

DATE ISSUED: May 9, 2012

EFFECTIVE DATE: July 1, 2012

Kenneth Mason
Vice President – Government & Regulatory Affairs
Citizens Communications Company
180 S. Clinton Ave.
Rochester, NY 14646

ACCESS SERVICE

6. Reserved For Future Use

(T)

(D)

(D)

Continued

DATE ISSUED: May 9, 2012

EFFECTIVE DATE: July 1, 2012

Kenneth Mason
Vice President – Government & Regulatory Affairs
Citizens Communications Company
180 S. Clinton Ave.
Rochester, NY 14646

ACCESS SERVICE

6. Reserved For Future Use

(T)

(D)

(D)

Continued

DATE ISSUED: May 9, 2012

EFFECTIVE DATE: July 1, 2012

Kenneth Mason
Vice President – Government & Regulatory Affairs
Citizens Communications Company
180 S. Clinton Ave.
Rochester, NY 14646

ACCESS SERVICE

6. Reserved For Future Use

(T)

(D)

(D)

Continued

DATE ISSUED: May 9, 2012

EFFECTIVE DATE: July 1, 2012

Kenneth Mason
Vice President – Government & Regulatory Affairs
Citizens Communications Company
180 S. Clinton Ave.
Rochester, NY 14646

ACCESS SERVICE

6. Reserved For Future Use

(T)

(D)

(D)

Continued

DATE ISSUED: May 9, 2012

EFFECTIVE DATE: July 1, 2012

Kenneth Mason
Vice President – Government & Regulatory Affairs
Citizens Communications Company
180 S. Clinton Ave.
Rochester, NY 14646

ACCESS SERVICE

6. Reserved For Future Use

(T)

(D)

(D)

Continued

DATE ISSUED: May 9, 2012

EFFECTIVE DATE: July 1, 2012

Kenneth Mason
Vice President – Government & Regulatory Affairs
Citizens Communications Company
180 S. Clinton Ave.
Rochester, NY 14646

ACCESS SERVICE

6. Reserved For Future Use

(T)

(D)

(D)

Continued

DATE ISSUED: May 9, 2012

EFFECTIVE DATE: July 1, 2012

Kenneth Mason
Vice President – Government & Regulatory Affairs
Citizens Communications Company
180 S. Clinton Ave.
Rochester, NY 14646

ACCESS SERVICE

6. Reserved For Future Use

(T)

(D)

(D)

Continued

DATE ISSUED: May 9, 2012

EFFECTIVE DATE: July 1, 2012

Kenneth Mason
Vice President – Government & Regulatory Affairs
Citizens Communications Company
180 S. Clinton Ave.
Rochester, NY 14646

ACCESS SERVICE

6. Reserved For Future Use

(T)

(D)

(D)

Continued

DATE ISSUED: May 9, 2012

EFFECTIVE DATE: July 1, 2012

Kenneth Mason
Vice President – Government & Regulatory Affairs
Citizens Communications Company
180 S. Clinton Ave.
Rochester, NY 14646

ACCESS SERVICE

6. Reserved For Future Use

(T)

(D)

(D)

Continued

DATE ISSUED: May 9, 2012

EFFECTIVE DATE: July 1, 2012

Kenneth Mason
Vice President – Government & Regulatory Affairs
Citizens Communications Company
180 S. Clinton Ave.
Rochester, NY 14646

ACCESS SERVICE

6. Reserved For Future Use

(T)

(D)

(D)

Continued

DATE ISSUED: May 9, 2012

EFFECTIVE DATE: July 1, 2012

Kenneth Mason
Vice President – Government & Regulatory Affairs
Citizens Communications Company
180 S. Clinton Ave.
Rochester, NY 14646

ACCESS SERVICE

6. Reserved For Future Use

(T)

(D)

(D)

Continued

DATE ISSUED: May 9, 2012

EFFECTIVE DATE: July 1, 2012

Kenneth Mason
Vice President – Government & Regulatory Affairs
Citizens Communications Company
180 S. Clinton Ave.
Rochester, NY 14646

ACCESS SERVICE

6. Reserved For Future Use

(T)

(D)

(D)

Continued

DATE ISSUED: May 9, 2012

EFFECTIVE DATE: July 1, 2012

Kenneth Mason
Vice President – Government & Regulatory Affairs
Citizens Communications Company
180 S. Clinton Ave.
Rochester, NY 14646

ACCESS SERVICE

6. Reserved For Future Use

(T)

(D)

(D)

Continued

DATE ISSUED: May 9, 2012

EFFECTIVE DATE: July 1, 2012

Kenneth Mason
Vice President – Government & Regulatory Affairs
Citizens Communications Company
180 S. Clinton Ave.
Rochester, NY 14646

ACCESS SERVICE

6. Reserved For Future Use

(T)

(D)

(D)

Continued

DATE ISSUED: May 9, 2012

EFFECTIVE DATE: July 1, 2012

Kenneth Mason
Vice President – Government & Regulatory Affairs
Citizens Communications Company
180 S. Clinton Ave.
Rochester, NY 14646

ACCESS SERVICE

6. Reserved For Future Use

(T)

(D)

(D)

Continued

DATE ISSUED: May 9, 2012

EFFECTIVE DATE: July 1, 2012

Kenneth Mason
Vice President – Government & Regulatory Affairs
Citizens Communications Company
180 S. Clinton Ave.
Rochester, NY 14646

ACCESS SERVICE

6. Reserved For Future Use

(T)

(D)

(D)

Continued

DATE ISSUED: May 9, 2012

EFFECTIVE DATE: July 1, 2012

Kenneth Mason
Vice President – Government & Regulatory Affairs
Citizens Communications Company
180 S. Clinton Ave.
Rochester, NY 14646

ACCESS SERVICE

6. Reserved For Future Use

(T)

(D)

(D)

Continued

DATE ISSUED: May 9, 2012

EFFECTIVE DATE: July 1, 2012

Kenneth Mason
Vice President – Government & Regulatory Affairs
Citizens Communications Company
180 S. Clinton Ave.
Rochester, NY 14646

ACCESS SERVICE

6. Reserved For Future Use

(T)

(D)

(D)

Continued

DATE ISSUED: May 9, 2012

EFFECTIVE DATE: July 1, 2012

Kenneth Mason
Vice President – Government & Regulatory Affairs
Citizens Communications Company
180 S. Clinton Ave.
Rochester, NY 14646

ACCESS SERVICE

6. Reserved For Future Use

(T)

(D)

(D)

Continued

DATE ISSUED: May 9, 2012

EFFECTIVE DATE: July 1, 2012

Kenneth Mason
Vice President – Government & Regulatory Affairs
Citizens Communications Company
180 S. Clinton Ave.
Rochester, NY 14646

ACCESS SERVICE

6. Reserved For Future Use

(T)

(D)

(D)

Continued

DATE ISSUED: May 9, 2012

EFFECTIVE DATE: July 1, 2012

Kenneth Mason
Vice President – Government & Regulatory Affairs
Citizens Communications Company
180 S. Clinton Ave.
Rochester, NY 14646

ACCESS SERVICE

6. Reserved For Future Use

(T)

(D)

(D)

Continued

DATE ISSUED: May 9, 2012

EFFECTIVE DATE: July 1, 2012

Kenneth Mason
Vice President – Government & Regulatory Affairs
Citizens Communications Company
180 S. Clinton Ave.
Rochester, NY 14646

ACCESS SERVICE

6. Reserved For Future Use

(T)

(D)

(D)

Continued

DATE ISSUED: May 9, 2012

EFFECTIVE DATE: July 1, 2012

Kenneth Mason
Vice President – Government & Regulatory Affairs
Citizens Communications Company
180 S. Clinton Ave.
Rochester, NY 14646

ACCESS SERVICE

6. Reserved For Future Use

(T)

(D)

(D)

Continued

DATE ISSUED: May 9, 2012

EFFECTIVE DATE: July 1, 2012

Kenneth Mason
Vice President – Government & Regulatory Affairs
Citizens Communications Company
180 S. Clinton Ave.
Rochester, NY 14646

ACCESS SERVICE

6. Reserved For Future Use

(T)

(D)

(D)

Continued

DATE ISSUED: May 9, 2012

EFFECTIVE DATE: July 1, 2012

Kenneth Mason
Vice President – Government & Regulatory Affairs
Citizens Communications Company
180 S. Clinton Ave.
Rochester, NY 14646

ACCESS SERVICE

6. Reserved For Future Use

(T)

(D)

(D)

Continued

DATE ISSUED: May 9, 2012

EFFECTIVE DATE: July 1, 2012

Kenneth Mason
Vice President – Government & Regulatory Affairs
Citizens Communications Company
180 S. Clinton Ave.
Rochester, NY 14646

ACCESS SERVICE

6. Reserved For Future Use

(T)

(D)

(D)

Continued

DATE ISSUED: May 9, 2012

EFFECTIVE DATE: July 1, 2012

Kenneth Mason
Vice President – Government & Regulatory Affairs
Citizens Communications Company
180 S. Clinton Ave.
Rochester, NY 14646

ACCESS SERVICE

6. Reserved For Future Use

(T)

(D)

(D)

Continued

DATE ISSUED: May 9, 2012

EFFECTIVE DATE: July 1, 2012

Kenneth Mason
Vice President – Government & Regulatory Affairs
Citizens Communications Company
180 S. Clinton Ave.
Rochester, NY 14646

ACCESS SERVICE

6. Reserved For Future Use

(T)

(D)

(D)

Continued

DATE ISSUED: May 9, 2012

EFFECTIVE DATE: July 1, 2012

Kenneth Mason
Vice President – Government & Regulatory Affairs
Citizens Communications Company
180 S. Clinton Ave.
Rochester, NY 14646

ACCESS SERVICE

6. Reserved For Future Use

(T)

(D)

(D)

Continued

DATE ISSUED: May 9, 2012

EFFECTIVE DATE: July 1, 2012

Kenneth Mason
Vice President – Government & Regulatory Affairs
Citizens Communications Company
180 S. Clinton Ave.
Rochester, NY 14646

ACCESS SERVICE

6. Reserved For Future Use

(T)

(D)

(D)

Continued

DATE ISSUED: May 9, 2012

EFFECTIVE DATE: July 1, 2012

Kenneth Mason
Vice President – Government & Regulatory Affairs
Citizens Communications Company
180 S. Clinton Ave.
Rochester, NY 14646

ACCESS SERVICE

6. Reserved For Future Use

(T)

(D)

(D)

Continued

DATE ISSUED: May 9, 2012

EFFECTIVE DATE: July 1, 2012

Kenneth Mason
Vice President – Government & Regulatory Affairs
Citizens Communications Company
180 S. Clinton Ave.
Rochester, NY 14646

ACCESS SERVICE

6. Reserved For Future Use

(T)

(D)

(D)

Continued

DATE ISSUED: May 9, 2012

EFFECTIVE DATE: July 1, 2012

Kenneth Mason
Vice President – Government & Regulatory Affairs
Citizens Communications Company
180 S. Clinton Ave.
Rochester, NY 14646

ACCESS SERVICE

6. Reserved For Future Use

(T)

(D)

(D)

Continued

DATE ISSUED: May 9, 2012

EFFECTIVE DATE: July 1, 2012

Kenneth Mason
Vice President – Government & Regulatory Affairs
Citizens Communications Company
180 S. Clinton Ave.
Rochester, NY 14646

ACCESS SERVICE

6. Reserved For Future Use

(T)

(D)

(D)

Continued

DATE ISSUED: May 9, 2012

EFFECTIVE DATE: July 1, 2012

Kenneth Mason
Vice President – Government & Regulatory Affairs
Citizens Communications Company
180 S. Clinton Ave.
Rochester, NY 14646

ACCESS SERVICE

6. Reserved For Future Use

(T)

(D)

(D)

Continued

DATE ISSUED: May 9, 2012

EFFECTIVE DATE: July 1, 2012

Kenneth Mason
Vice President – Government & Regulatory Affairs
Citizens Communications Company
180 S. Clinton Ave.
Rochester, NY 14646

ACCESS SERVICE

6. Reserved For Future Use

(T)

(D)

(D)

Continued

DATE ISSUED: May 9, 2012

EFFECTIVE DATE: July 1, 2012

Kenneth Mason
Vice President – Government & Regulatory Affairs
Citizens Communications Company
180 S. Clinton Ave.
Rochester, NY 14646

ACCESS SERVICE

6. Reserved For Future Use

(T)

(D)

(D)

Continued

DATE ISSUED: May 9, 2012

EFFECTIVE DATE: July 1, 2012

Kenneth Mason
Vice President – Government & Regulatory Affairs
Citizens Communications Company
180 S. Clinton Ave.
Rochester, NY 14646

ACCESS SERVICE

6. Reserved For Future Use

(T)

(D)

(D)

Continued

DATE ISSUED: May 9, 2012

EFFECTIVE DATE: July 1, 2012

Kenneth Mason
Vice President – Government & Regulatory Affairs
Citizens Communications Company
180 S. Clinton Ave.
Rochester, NY 14646

ACCESS SERVICE

6. Reserved For Future Use

(T)

(D)

(D)

Continued

DATE ISSUED: May 9, 2012

EFFECTIVE DATE: July 1, 2012

Kenneth Mason
Vice President – Government & Regulatory Affairs
Citizens Communications Company
180 S. Clinton Ave.
Rochester, NY 14646

ACCESS SERVICE

6. Reserved For Future Use

(T)

(D)

(D)

Continued

DATE ISSUED: May 9, 2012

EFFECTIVE DATE: July 1, 2012

Kenneth Mason
Vice President – Government & Regulatory Affairs
Citizens Communications Company
180 S. Clinton Ave.
Rochester, NY 14646

ACCESS SERVICE

6. Reserved For Future Use

(T)

(D)

(D)

Continued

DATE ISSUED: May 9, 2012

EFFECTIVE DATE: July 1, 2012

Kenneth Mason
Vice President – Government & Regulatory Affairs
Citizens Communications Company
180 S. Clinton Ave.
Rochester, NY 14646

ACCESS SERVICE

6. Reserved For Future Use

(T)

(D)

(D)

Continued

DATE ISSUED: May 9, 2012

EFFECTIVE DATE: July 1, 2012

Kenneth Mason
Vice President – Government & Regulatory Affairs
Citizens Communications Company
180 S. Clinton Ave.
Rochester, NY 14646

ACCESS SERVICE

6. Reserved For Future Use

(T)

(D)

(D)

Continued

DATE ISSUED: May 9, 2012

EFFECTIVE DATE: July 1, 2012

Kenneth Mason
Vice President – Government & Regulatory Affairs
Citizens Communications Company
180 S. Clinton Ave.
Rochester, NY 14646

ACCESS SERVICE

6. Reserved For Future Use

(T)

(D)

(D)

Continued

DATE ISSUED: May 9, 2012

EFFECTIVE DATE: July 1, 2012

Kenneth Mason
Vice President – Government & Regulatory Affairs
Citizens Communications Company
180 S. Clinton Ave.
Rochester, NY 14646

ACCESS SERVICE

6. Reserved For Future Use

(T)

(D)

(D)

Continued

DATE ISSUED: May 9, 2012

EFFECTIVE DATE: July 1, 2012

Kenneth Mason
Vice President – Government & Regulatory Affairs
Citizens Communications Company
180 S. Clinton Ave.
Rochester, NY 14646

ACCESS SERVICE

6. Reserved For Future Use

(T)

(D)

(D)

Continued

DATE ISSUED: May 9, 2012

EFFECTIVE DATE: July 1, 2012

Kenneth Mason
Vice President – Government & Regulatory Affairs
Citizens Communications Company
180 S. Clinton Ave.
Rochester, NY 14646

ACCESS SERVICE

6. Reserved For Future Use

(T)

(D)

(D)

Continued

DATE ISSUED: May 9, 2012

EFFECTIVE DATE: July 1, 2012

Kenneth Mason
Vice President – Government & Regulatory Affairs
Citizens Communications Company
180 S. Clinton Ave.
Rochester, NY 14646

ACCESS SERVICE

6. Reserved For Future Use

(T)

(D)

(D)

Continued

DATE ISSUED: May 9, 2012

EFFECTIVE DATE: July 1, 2012

Kenneth Mason
Vice President – Government & Regulatory Affairs
Citizens Communications Company
180 S. Clinton Ave.
Rochester, NY 14646

ACCESS SERVICE

6. Reserved For Future Use

(T)

(D)

(D)

Continued

DATE ISSUED: May 9, 2012

EFFECTIVE DATE: July 1, 2012

Kenneth Mason
Vice President – Government & Regulatory Affairs
Citizens Communications Company
180 S. Clinton Ave.
Rochester, NY 14646

ACCESS SERVICE

6. Reserved For Future Use

(T)

(D)

(D)

Continued

DATE ISSUED: May 9, 2012

EFFECTIVE DATE: July 1, 2012

Kenneth Mason
Vice President – Government & Regulatory Affairs
Citizens Communications Company
180 S. Clinton Ave.
Rochester, NY 14646

ACCESS SERVICE

6. Reserved For Future Use

(T)

(D)

(D)

Continued

DATE ISSUED: May 9, 2012

EFFECTIVE DATE: July 1, 2012

Kenneth Mason
Vice President – Government & Regulatory Affairs
Citizens Communications Company
180 S. Clinton Ave.
Rochester, NY 14646

ACCESS SERVICE

6. Reserved For Future Use

(T)

(D)

(D)

Continued

DATE ISSUED: May 9, 2012

EFFECTIVE DATE: July 1, 2012

Kenneth Mason
Vice President – Government & Regulatory Affairs
Citizens Communications Company
180 S. Clinton Ave.
Rochester, NY 14646

ACCESS SERVICE

6. Reserved For Future Use

(T)

(D)

(D)

Continued

DATE ISSUED: May 9, 2012

EFFECTIVE DATE: July 1, 2012

Kenneth Mason
Vice President – Government & Regulatory Affairs
Citizens Communications Company
180 S. Clinton Ave.
Rochester, NY 14646

ACCESS SERVICE

6. Reserved For Future Use

(T)

(D)

(D)

Continued

DATE ISSUED: May 9, 2012

EFFECTIVE DATE: July 1, 2012

Kenneth Mason
Vice President – Government & Regulatory Affairs
Citizens Communications Company
180 S. Clinton Ave.
Rochester, NY 14646

ACCESS SERVICE

6. Reserved For Future Use

(T)

(D)

(D)

Continued

DATE ISSUED: May 9, 2012

EFFECTIVE DATE: July 1, 2012

Kenneth Mason
Vice President – Government & Regulatory Affairs
Citizens Communications Company
180 S. Clinton Ave.
Rochester, NY 14646

ACCESS SERVICE

6. Reserved For Future Use

(T)

(D)

(D)

Continued

DATE ISSUED: May 9, 2012

EFFECTIVE DATE: July 1, 2012

Kenneth Mason
Vice President – Government & Regulatory Affairs
Citizens Communications Company
180 S. Clinton Ave.
Rochester, NY 14646

ACCESS SERVICE

6. Reserved For Future Use

(T)

(D)

(D)

Continued

DATE ISSUED: May 9, 2012

EFFECTIVE DATE: July 1, 2012

Kenneth Mason
Vice President – Government & Regulatory Affairs
Citizens Communications Company
180 S. Clinton Ave.
Rochester, NY 14646

ACCESS SERVICE

6. Reserved For Future Use

(T)

(D)

(D)

Continued

DATE ISSUED: May 9, 2012

EFFECTIVE DATE: July 1, 2012

Kenneth Mason
Vice President – Government & Regulatory Affairs
Citizens Communications Company
180 S. Clinton Ave.
Rochester, NY 14646

ACCESS SERVICE

6. Reserved For Future Use

(T)

(D)

(D)

Continued

DATE ISSUED: May 9, 2012

EFFECTIVE DATE: July 1, 2012

Kenneth Mason
Vice President – Government & Regulatory Affairs
Citizens Communications Company
180 S. Clinton Ave.
Rochester, NY 14646

ACCESS SERVICE

6. Reserved For Future Use

(T)

(D)

(D)

Continued

DATE ISSUED: May 9, 2012

EFFECTIVE DATE: July 1, 2012

Kenneth Mason
Vice President – Government & Regulatory Affairs
Citizens Communications Company
180 S. Clinton Ave.
Rochester, NY 14646

ACCESS SERVICE

6. Reserved For Future Use

(T)

(D)

(D)

Continued

DATE ISSUED: May 9, 2012

EFFECTIVE DATE: July 1, 2012

Kenneth Mason
Vice President – Government & Regulatory Affairs
Citizens Communications Company
180 S. Clinton Ave.
Rochester, NY 14646

ACCESS SERVICE

6. Reserved For Future Use

(T)

(D)

(D)

Continued

DATE ISSUED: May 9, 2012

EFFECTIVE DATE: July 1, 2012

Kenneth Mason
Vice President – Government & Regulatory Affairs
Citizens Communications Company
180 S. Clinton Ave.
Rochester, NY 14646

ACCESS SERVICE

6. Reserved For Future Use

(T)

(D)

(D)

Continued

DATE ISSUED: May 9, 2012

EFFECTIVE DATE: July 1, 2012

Kenneth Mason
Vice President – Government & Regulatory Affairs
Citizens Communications Company
180 S. Clinton Ave.
Rochester, NY 14646

ACCESS SERVICE

6. Reserved For Future Use

(T)

(D)

(D)

Continued

DATE ISSUED: May 9, 2012

EFFECTIVE DATE: July 1, 2012

Kenneth Mason
Vice President – Government & Regulatory Affairs
Citizens Communications Company
180 S. Clinton Ave.
Rochester, NY 14646

ACCESS SERVICE

6. Reserved For Future Use

(T)

(D)

(D)

Continued

DATE ISSUED: May 9, 2012

EFFECTIVE DATE: July 1, 2012

Kenneth Mason
Vice President – Government & Regulatory Affairs
Citizens Communications Company
180 S. Clinton Ave.
Rochester, NY 14646

ACCESS SERVICE

6. Reserved For Future Use

(T)

(D)

(D)

Continued

DATE ISSUED: May 9, 2012

EFFECTIVE DATE: July 1, 2012

Kenneth Mason
Vice President – Government & Regulatory Affairs
Citizens Communications Company
180 S. Clinton Ave.
Rochester, NY 14646

ACCESS SERVICE

6. Reserved For Future Use

(T)

(D)

(D)

Continued

DATE ISSUED: May 9, 2012

EFFECTIVE DATE: July 1, 2012

Kenneth Mason
Vice President – Government & Regulatory Affairs
Citizens Communications Company
180 S. Clinton Ave.
Rochester, NY 14646

ACCESS SERVICE

6. Reserved For Future Use

(T)

(D)

(D)

Continued

DATE ISSUED: May 9, 2012

EFFECTIVE DATE: July 1, 2012

Kenneth Mason
Vice President – Government & Regulatory Affairs
Citizens Communications Company
180 S. Clinton Ave.
Rochester, NY 14646

ACCESS SERVICE

6. Reserved For Future Use

(T)

(D)

(D)

Continued

DATE ISSUED: May 9, 2012

EFFECTIVE DATE: July 1, 2012

Kenneth Mason
Vice President – Government & Regulatory Affairs
Citizens Communications Company
180 S. Clinton Ave.
Rochester, NY 14646

ACCESS SERVICE

6. Reserved For Future Use

(T)

(D)

(D)

Continued

DATE ISSUED: May 9, 2012

EFFECTIVE DATE: July 1, 2012

Kenneth Mason
Vice President – Government & Regulatory Affairs
Citizens Communications Company
180 S. Clinton Ave.
Rochester, NY 14646

ACCESS SERVICE

6. Reserved For Future Use

(T)

(D)

(D)

Continued

DATE ISSUED: May 9, 2012

EFFECTIVE DATE: July 1, 2012

Kenneth Mason
Vice President – Government & Regulatory Affairs
Citizens Communications Company
180 S. Clinton Ave.
Rochester, NY 14646

ACCESS SERVICE

6. Reserved For Future Use

(T)

(D)

(D)

Continued

DATE ISSUED: May 9, 2012

EFFECTIVE DATE: July 1, 2012

Kenneth Mason
Vice President – Government & Regulatory Affairs
Citizens Communications Company
180 S. Clinton Ave.
Rochester, NY 14646

ACCESS SERVICE

6. Reserved For Future Use

(T)

(D)

(D)

Continued

DATE ISSUED: May 9, 2012

EFFECTIVE DATE: July 1, 2012

Kenneth Mason
Vice President – Government & Regulatory Affairs
Citizens Communications Company
180 S. Clinton Ave.
Rochester, NY 14646

ACCESS SERVICE

6. Reserved For Future Use

(T)

(D)

(D)

Continued

DATE ISSUED: May 9, 2012

EFFECTIVE DATE: July 1, 2012

Kenneth Mason
Vice President – Government & Regulatory Affairs
Citizens Communications Company
180 S. Clinton Ave.
Rochester, NY 14646

ACCESS SERVICE

6. Reserved For Future Use

(T)

(D)

(D)

Continued

DATE ISSUED: May 9, 2012

EFFECTIVE DATE: July 1, 2012

Kenneth Mason
Vice President – Government & Regulatory Affairs
Citizens Communications Company
180 S. Clinton Ave.
Rochester, NY 14646

ACCESS SERVICE

6. Reserved For Future Use

(T)

(D)

(D)

Continued

DATE ISSUED: May 9, 2012

EFFECTIVE DATE: July 1, 2012

Kenneth Mason
Vice President – Government & Regulatory Affairs
Citizens Communications Company
180 S. Clinton Ave.
Rochester, NY 14646

ACCESS SERVICE

6. Reserved For Future Use

(T)

(D)

(D)

Continued

DATE ISSUED: May 9, 2012

EFFECTIVE DATE: July 1, 2012

Kenneth Mason
Vice President – Government & Regulatory Affairs
Citizens Communications Company
180 S. Clinton Ave.
Rochester, NY 14646

ACCESS SERVICE

6. Reserved For Future Use

(T)

(D)

(D)

Continued

DATE ISSUED: May 9, 2012

EFFECTIVE DATE: July 1, 2012

Kenneth Mason
Vice President – Government & Regulatory Affairs
Citizens Communications Company
180 S. Clinton Ave.
Rochester, NY 14646

ACCESS SERVICE

6. Reserved For Future Use

(T)

(D)

(D)

Continued

DATE ISSUED: May 9, 2012

EFFECTIVE DATE: July 1, 2012

Kenneth Mason
Vice President – Government & Regulatory Affairs
Citizens Communications Company
180 S. Clinton Ave.
Rochester, NY 14646

ACCESS SERVICE

6. Reserved For Future Use

(T)

(D)

(D)

Continued

DATE ISSUED: May 9, 2012

EFFECTIVE DATE: July 1, 2012

Kenneth Mason
Vice President – Government & Regulatory Affairs
Citizens Communications Company
180 S. Clinton Ave.
Rochester, NY 14646

ACCESS SERVICE

6. Reserved For Future Use

(T)

(D)

(D)

Continued

DATE ISSUED: May 9, 2012

EFFECTIVE DATE: July 1, 2012

Kenneth Mason
Vice President – Government & Regulatory Affairs
Citizens Communications Company
180 S. Clinton Ave.
Rochester, NY 14646

ACCESS SERVICE

6. Reserved For Future Use

(T)

(D)

(D)

Continued

DATE ISSUED: May 9, 2012

EFFECTIVE DATE: July 1, 2012

Kenneth Mason
Vice President – Government & Regulatory Affairs
Citizens Communications Company
180 S. Clinton Ave.
Rochester, NY 14646

ACCESS SERVICE

6. Reserved For Future Use

(T)

(D)

(D)

Continued

DATE ISSUED: May 9, 2012

EFFECTIVE DATE: July 1, 2012

Kenneth Mason
Vice President – Government & Regulatory Affairs
Citizens Communications Company
180 S. Clinton Ave.
Rochester, NY 14646

ACCESS SERVICE

6. Reserved For Future Use

(T)

(D)

(D)

Continued

DATE ISSUED: May 9, 2012

EFFECTIVE DATE: July 1, 2012

Kenneth Mason
Vice President – Government & Regulatory Affairs
Citizens Communications Company
180 S. Clinton Ave.
Rochester, NY 14646

ACCESS SERVICE

6. Reserved For Future Use

(T)

(D)

(D)

Continued

DATE ISSUED: May 9, 2012

EFFECTIVE DATE: July 1, 2012

Kenneth Mason
Vice President – Government & Regulatory Affairs
Citizens Communications Company
180 S. Clinton Ave.
Rochester, NY 14646

ACCESS SERVICE

6. Reserved For Future Use

(T)

(D)

(D)

Continued

DATE ISSUED: May 9, 2012

EFFECTIVE DATE: July 1, 2012

Kenneth Mason
Vice President – Government & Regulatory Affairs
Citizens Communications Company
180 S. Clinton Ave.
Rochester, NY 14646

ACCESS SERVICE

6. Reserved For Future Use

(T)

(D)

(D)

Continued

DATE ISSUED: May 9, 2012

EFFECTIVE DATE: July 1, 2012

Kenneth Mason
Vice President – Government & Regulatory Affairs
Citizens Communications Company
180 S. Clinton Ave.
Rochester, NY 14646

ACCESS SERVICE

6. Reserved For Future Use

(T)

(D)

(D)

Continued

DATE ISSUED: May 9, 2012

EFFECTIVE DATE: July 1, 2012

Kenneth Mason
Vice President – Government & Regulatory Affairs
Citizens Communications Company
180 S. Clinton Ave.
Rochester, NY 14646

ACCESS SERVICE

6. Reserved For Future Use

(T)

(D)

(D)

Continued

DATE ISSUED: May 9, 2012

EFFECTIVE DATE: July 1, 2012

Kenneth Mason
Vice President – Government & Regulatory Affairs
Citizens Communications Company
180 S. Clinton Ave.
Rochester, NY 14646

ACCESS SERVICE

6. Reserved For Future Use

(T)

(D)

(D)

Continued

DATE ISSUED: May 9, 2012

EFFECTIVE DATE: July 1, 2012

Kenneth Mason
Vice President – Government & Regulatory Affairs
Citizens Communications Company
180 S. Clinton Ave.
Rochester, NY 14646

ACCESS SERVICE

6. Reserved For Future Use

(T)

(D)

(D)

Continued

DATE ISSUED: May 9, 2012

EFFECTIVE DATE: July 1, 2012

Kenneth Mason
Vice President – Government & Regulatory Affairs
Citizens Communications Company
180 S. Clinton Ave.
Rochester, NY 14646

ACCESS SERVICE

6. Reserved For Future Use

(T)

(D)

(D)

Continued

DATE ISSUED: May 9, 2012

EFFECTIVE DATE: July 1, 2012

Kenneth Mason
Vice President – Government & Regulatory Affairs
Citizens Communications Company
180 S. Clinton Ave.
Rochester, NY 14646

ACCESS SERVICE

6. Reserved For Future Use

(T)

(D)

(D)

Continued

DATE ISSUED: May 9, 2012

EFFECTIVE DATE: July 1, 2012

Kenneth Mason
Vice President – Government & Regulatory Affairs
Citizens Communications Company
180 S. Clinton Ave.
Rochester, NY 14646

ACCESS SERVICE

6. Reserved For Future Use

(T)

(D)

(D)

Continued

DATE ISSUED: May 9, 2012

EFFECTIVE DATE: July 1, 2012

Kenneth Mason
Vice President – Government & Regulatory Affairs
Citizens Communications Company
180 S. Clinton Ave.
Rochester, NY 14646

ACCESS SERVICE

6. Reserved For Future Use

(T)

(D)

(D)

Continued

DATE ISSUED: May 9, 2012

EFFECTIVE DATE: July 1, 2012

Kenneth Mason
Vice President – Government & Regulatory Affairs
Citizens Communications Company
180 S. Clinton Ave.
Rochester, NY 14646

ACCESS SERVICE

6. Reserved For Future Use

(T)

(D)

(D)

Continued

DATE ISSUED: May 9, 2012

EFFECTIVE DATE: July 1, 2012

Kenneth Mason
Vice President – Government & Regulatory Affairs
Citizens Communications Company
180 S. Clinton Ave.
Rochester, NY 14646

ACCESS SERVICE

6. Reserved For Future Use

(T)

(D)

(D)

Continued

DATE ISSUED: May 9, 2012

EFFECTIVE DATE: July 1, 2012

Kenneth Mason
Vice President – Government & Regulatory Affairs
Citizens Communications Company
180 S. Clinton Ave.
Rochester, NY 14646

ACCESS SERVICE

6. Reserved For Future Use

(T)

(D)

(D)

Continued

DATE ISSUED: May 9, 2012

EFFECTIVE DATE: July 1, 2012

Kenneth Mason
Vice President – Government & Regulatory Affairs
Citizens Communications Company
180 S. Clinton Ave.
Rochester, NY 14646

ACCESS SERVICE

6. Reserved For Future Use

(T)

(D)

(D)

Continued

DATE ISSUED: May 9, 2012

EFFECTIVE DATE: July 1, 2012

Kenneth Mason
Vice President – Government & Regulatory Affairs
Citizens Communications Company
180 S. Clinton Ave.
Rochester, NY 14646

ACCESS SERVICE

6. Reserved For Future Use

(T)

(D)

(D)

Continued

DATE ISSUED: May 9, 2012

EFFECTIVE DATE: July 1, 2012

Kenneth Mason
Vice President – Government & Regulatory Affairs
Citizens Communications Company
180 S. Clinton Ave.
Rochester, NY 14646

ACCESS SERVICE

6. Reserved For Future Use

(T)

(D)

(D)

Continued

DATE ISSUED: May 9, 2012

EFFECTIVE DATE: July 1, 2012

Kenneth Mason
Vice President – Government & Regulatory Affairs
Citizens Communications Company
180 S. Clinton Ave.
Rochester, NY 14646

ACCESS SERVICE

6. Reserved For Future Use

(T)

(D)

(D)

Continued

DATE ISSUED: May 9, 2012

EFFECTIVE DATE: July 1, 2012

Kenneth Mason
Vice President – Government & Regulatory Affairs
Citizens Communications Company
180 S. Clinton Ave.
Rochester, NY 14646

ACCESS SERVICE

6. Reserved For Future Use

(T)

(D)

(D)

Continued

DATE ISSUED: May 9, 2012

EFFECTIVE DATE: July 1, 2012

Kenneth Mason
Vice President – Government & Regulatory Affairs
Citizens Communications Company
180 S. Clinton Ave.
Rochester, NY 14646

ACCESS SERVICE

6. Reserved For Future Use

(T)

(D)

(D)

Continued

DATE ISSUED: May 9, 2012

EFFECTIVE DATE: July 1, 2012

Kenneth Mason
Vice President – Government & Regulatory Affairs
Citizens Communications Company
180 S. Clinton Ave.
Rochester, NY 14646

ACCESS SERVICE

6. Reserved For Future Use

(T)

(D)

(D)

Continued

DATE ISSUED: May 9, 2012

EFFECTIVE DATE: July 1, 2012

Kenneth Mason
Vice President – Government & Regulatory Affairs
Citizens Communications Company
180 S. Clinton Ave.
Rochester, NY 14646

ACCESS SERVICE

6. Reserved For Future Use

(T)

(D)

(D)

Continued

DATE ISSUED: May 9, 2012

EFFECTIVE DATE: July 1, 2012

Kenneth Mason
Vice President – Government & Regulatory Affairs
Citizens Communications Company
180 S. Clinton Ave.
Rochester, NY 14646

ACCESS SERVICE

6. Reserved For Future Use

(T)

(D)

(D)

Continued

DATE ISSUED: May 9, 2012

EFFECTIVE DATE: July 1, 2012

Kenneth Mason
Vice President – Government & Regulatory Affairs
Citizens Communications Company
180 S. Clinton Ave.
Rochester, NY 14646

ACCESS SERVICE

6. Reserved For Future Use

(T)

(D)

(D)

Continued

DATE ISSUED: May 9, 2012

EFFECTIVE DATE: July 1, 2012

Kenneth Mason
Vice President – Government & Regulatory Affairs
Citizens Communications Company
180 S. Clinton Ave.
Rochester, NY 14646

ACCESS SERVICE

6. Reserved For Future Use

(T)

(D)

(D)

Continued

DATE ISSUED: May 9, 2012

EFFECTIVE DATE: July 1, 2012

Kenneth Mason
Vice President – Government & Regulatory Affairs
Citizens Communications Company
180 S. Clinton Ave.
Rochester, NY 14646

ACCESS SERVICE

6. Reserved For Future Use

(T)

(D)

(D)

Continued

DATE ISSUED: May 9, 2012

EFFECTIVE DATE: July 1, 2012

Kenneth Mason
Vice President – Government & Regulatory Affairs
Citizens Communications Company
180 S. Clinton Ave.
Rochester, NY 14646

ACCESS SERVICE

6. Reserved For Future Use

(T)

(D)

(D)

Continued

DATE ISSUED: May 9, 2012

EFFECTIVE DATE: July 1, 2012

Kenneth Mason
Vice President – Government & Regulatory Affairs
Citizens Communications Company
180 S. Clinton Ave.
Rochester, NY 14646

ACCESS SERVICE

6. Reserved For Future Use

(T)

(D)

(D)

Continued

DATE ISSUED: May 9, 2012

EFFECTIVE DATE: July 1, 2012

Kenneth Mason
Vice President – Government & Regulatory Affairs
Citizens Communications Company
180 S. Clinton Ave.
Rochester, NY 14646

ACCESS SERVICE

6. Reserved For Future Use

(T)

(D)

(D)

Continued

DATE ISSUED: May 9, 2012

EFFECTIVE DATE: July 1, 2012

Kenneth Mason
Vice President – Government & Regulatory Affairs
Citizens Communications Company
180 S. Clinton Ave.
Rochester, NY 14646

ACCESS SERVICE

6. Reserved For Future Use

(T)

(D)

(D)

Continued

DATE ISSUED: May 9, 2012

EFFECTIVE DATE: July 1, 2012

Kenneth Mason
Vice President – Government & Regulatory Affairs
Citizens Communications Company
180 S. Clinton Ave.
Rochester, NY 14646

ACCESS SERVICE

6. Reserved For Future Use

(T)

(D)

(D)

Continued

DATE ISSUED: May 9, 2012

EFFECTIVE DATE: July 1, 2012

Kenneth Mason
Vice President – Government & Regulatory Affairs
Citizens Communications Company
180 S. Clinton Ave.
Rochester, NY 14646

ACCESS SERVICE

6. Reserved For Future Use

(T)

(D)

(D)

Continued

DATE ISSUED: May 9, 2012

EFFECTIVE DATE: July 1, 2012

Kenneth Mason
Vice President – Government & Regulatory Affairs
Citizens Communications Company
180 S. Clinton Ave.
Rochester, NY 14646

ACCESS SERVICE

6. Reserved For Future Use

(T)

(D)

(D)

Continued

DATE ISSUED: May 9, 2012

EFFECTIVE DATE: July 1, 2012

Kenneth Mason
Vice President – Government & Regulatory Affairs
Citizens Communications Company
180 S. Clinton Ave.
Rochester, NY 14646

ACCESS SERVICE

6. Reserved For Future Use

(T)

(D)

(D)

Continued

DATE ISSUED: May 9, 2012

EFFECTIVE DATE: July 1, 2012

Kenneth Mason
Vice President – Government & Regulatory Affairs
Citizens Communications Company
180 S. Clinton Ave.
Rochester, NY 14646

ACCESS SERVICE

6. Reserved For Future Use

(T)

(D)

(D)

Continued

DATE ISSUED: May 9, 2012

EFFECTIVE DATE: July 1, 2012

Kenneth Mason
Vice President – Government & Regulatory Affairs
Citizens Communications Company
180 S. Clinton Ave.
Rochester, NY 14646

ACCESS SERVICE

6. Reserved For Future Use

(T)

(D)

(D)

Continued

DATE ISSUED: May 9, 2012

EFFECTIVE DATE: July 1, 2012

Kenneth Mason
Vice President – Government & Regulatory Affairs
Citizens Communications Company
180 S. Clinton Ave.
Rochester, NY 14646

ACCESS SERVICE

6. Reserved For Future Use

(T)

(D)

(D)

Continued

DATE ISSUED: May 9, 2012

EFFECTIVE DATE: July 1, 2012

Kenneth Mason
Vice President – Government & Regulatory Affairs
Citizens Communications Company
180 S. Clinton Ave.
Rochester, NY 14646

ACCESS SERVICE

6. Reserved For Future Use

(T)

(D)

(D)

Continued

DATE ISSUED: May 9, 2012

EFFECTIVE DATE: July 1, 2012

Kenneth Mason
Vice President – Government & Regulatory Affairs
Citizens Communications Company
180 S. Clinton Ave.
Rochester, NY 14646

ACCESS SERVICE

6. Reserved For Future Use

(T)

(D)

(D)

Continued

DATE ISSUED: May 9, 2012

EFFECTIVE DATE: July 1, 2012

Kenneth Mason
Vice President – Government & Regulatory Affairs
Citizens Communications Company
180 S. Clinton Ave.
Rochester, NY 14646

ACCESS SERVICE

6. Reserved For Future Use

(T)

(D)

(D)

Continued

DATE ISSUED: May 9, 2012

EFFECTIVE DATE: July 1, 2012

Kenneth Mason
Vice President – Government & Regulatory Affairs
Citizens Communications Company
180 S. Clinton Ave.
Rochester, NY 14646

ACCESS SERVICE

6. Reserved For Future Use

(T)

(D)

(D)

Continued

DATE ISSUED: May 9, 2012

EFFECTIVE DATE: July 1, 2012

Kenneth Mason
Vice President – Government & Regulatory Affairs
Citizens Communications Company
180 S. Clinton Ave.
Rochester, NY 14646

ACCESS SERVICE

7. Special Access Service

7.1 Provision of Special Access Service

Special Access Service provides a dedicated transmission path to connect customer designated premises*, either directly or through a Telephone Company hub where bridging or multiplexing functions are performed. Special Access Service may also be combined with Switched Access Services in the provision of a customer's intrastate communications service (WATS, 800 or WATS-type Services). Special Access Service includes all exchange access not utilizing Telephone Company central office switches.

Certain Special Access Services listed in this section of the tariff may not be currently offered in all Telephone Company locations but may be provided upon customer request, on an individual case basis, if facilities can be made available with reasonable effort. The Telephone Company will work cooperatively with the Customer to provide the service on a timely basis.

7.1.1 Circuit Types

There are seven types of circuits used to provide Special Access Services:

- Metallic (MT)
- Voice Grade (VG)
- Program Audio
- Video
- Wideband Analog (WA)
- Digital Data (DA)
- High Capacity (HC)

* Telephone Company Centrex CO-like switches are considered to be customer premises for purposes of this tariff.

ACCESS SERVICE

7. Special Access Service (Cont'd)

7.1 Provision of Special Access Service (Cont'd)

7.1.1 Circuit Types (Cont'd)

These circuits can be either analog or digital. Analog circuits are differentiated by frequency spectrum and bandwidth. Digital connections are differentiated by bit rate.

Each of the nine circuits has its own characteristics. All of the circuit types are subdivided by one or more of the following:

- Transmission specifications,
- Bandwidth,
- Speed (i.e., bit rate),
- Spectrum

The circuit descriptions set forth in this section specify the characteristics of the basic circuit and indicates whether the circuit is provided between customer designated premises or between a customer designated premise and a Telephone Company hub where bridging or multiplexing functions are performed, or between a customer designated premise and a telephone company office capable of combining switched or special access services or a WATS serving office.

Customers can order a basic circuit and select from a list of available technical specifications packages (customized or pre-defined), channel interfaces, and optional features to design a circuit which meets the Customer's specific communications needs. For purposes of ordering circuits, each has been identified as a type of Special Access circuit. However, such identification is not intended to limit a customer's use of the circuit, nor to imply that a circuit is limited to a particular use.

** New or Revised*

Continued

DATRE ISSUED: July 31, 2002

EFFECTIVE DATE: September 18, 2002

Aloa J. Stevens
Director - State Regulatory Affairs
Citizens Communications Company
4 Triad Center, Suite 200
Salt Lake City, UT 84180

ACCESS SERVICE

7. Special Access Service (Cont'd)

7.1 Provision of Special Access Service (Cont'd)

7.1.1 Circuit Types (Cont'd)

The optional features and functions available with each type of basic circuit are included in the individual service description sections following. The optional features and functions information also indicates with which technical specifications packages they are available.

When a customized circuit is ordered, the Telephone Company may determine that Additional Engineering is required to meet the customer's request for service. The customer will be notified whether Additional Engineering charges apply and will be given an estimate of the hours to be billed before any further action is taken on the order. Additional engineering charges are determined as set forth in Section 8.1 following.

7.1.2 Service Configurations

There are two types of service configurations over which Special Access Services are provided: two-point service and multipoint service.

(A) Two-Point Service

A two-point service connects two customer designated premises, either on a directly connected basis or through a hub where multiplexing functions are performed. A Voice Grade Special Access Circuit may be provided as a two-point service connecting an end user premise and a Telephone Company switch when Special Access is used in conjunction with Switched Access as set forth in Section 6 (T) for Combined Access Service Arrangements.

Continued

DATE ISSUED: May 9, 2012

EFFECTIVE DATE: July 1, 2012

Kenneth Mason
Vice President – Government & Regulatory Affairs
Citizens Communications Company
180 S. Clinton Ave.
Rochester, NY 14646

ACCESS SERVICE

7. Special Access Service (Cont'd)7.1 Provision of Special Access Service (Cont'd)7.1.2 Service Configurations (Cont'd)(A) Two-Point Service (Cont'd)

All types of Special Access Service may be provided as two-point service.

The following diagram depicts an example of a two-point Voice Grade service connecting two customer designated premises located 15 miles apart. The service is provided with the optional feature of C-Type conditioning.

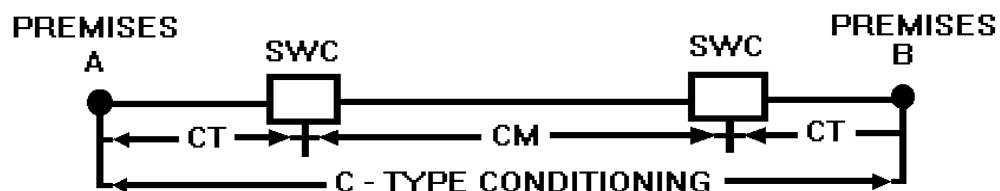

CT - Circuit Termination
 CM - Circuit Mileage
 SWC- Serving Wire Center

Applicable rate elements are:

- Circuit Termination (2 applicable)
- Circuit Mileage (fixed rate plus rate per airline mile between SWC)
- C-Type Conditioning Optional Feature

In addition, charges for additional Optional Features and Functions may apply.

** New or Revised*

Continued

DATRE ISSUED: July 31, 2002

EFFECTIVE DATE: September 18, 2002

Aloa J. Stevens
 Director - State Regulatory Affairs
 Citizens Communications Company
 4 Triad Center, Suite 200
 Salt Lake City, UT 84180

ACCESS SERVICE

7. Special Access Service (Cont'd)

7.1 Provision of Special Access Service (Cont'd)

7.1.2 Service Configurations (Cont'd)

(B) Multipoint Service

Multipoint service connects three or more customer designated premises through a Telephone Company hub (i.e., bridging locations). Only certain types of Special Access Service are provided as multipoint service. These are so designated in the Service Descriptions for the appropriate circuit.

The circuit between hubs on a multipoint service is a mid-link. There is no limitation on the number of mid-links, but the use of more than three mid-links in tandem may degrade the quality of multi-point facilities.

Multipoint service utilizing a customized technical specifications package, as set forth in 7.1.3, will be provided when technically possible.

When ordering, the customer will specify the desired bridging hub(s). Section 15 of this tariff identifies serving wire centers, hub locations and the type of bridging functions available.

** New or Revised*

Continued

DATRE ISSUED: July 31, 2002

EFFECTIVE DATE: September 18, 2002

Aloa J. Stevens
Director - State Regulatory Affairs
Citizens Communications Company
4 Triad Center, Suite 200
Salt Lake City, UT 84180

ACCESS SERVICE

7. Special Access Service (Cont'd)7.1 Provision of Special Access Service (Cont'd)7.1.2 Service Configurations (Cont'd)(B) Multipoint Service (Cont'd)

The following diagram depicts an example of a Voice Grade multi-point service connecting four customer premises via two customer specified bridging hubs.

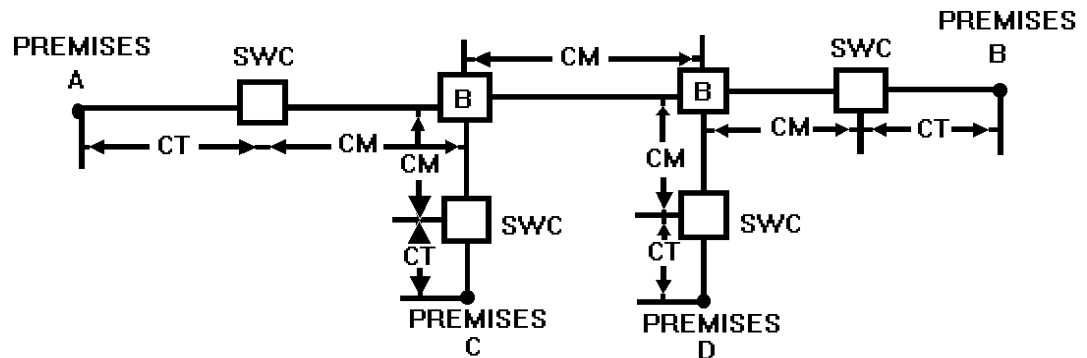

CT - Circuit Termination
 CM - Circuit Mileage
 B - Bridging
 SWC- Serving Wire Center

Applicable rate elements are:

- Circuit Termination (4 applicable)
- Circuit Mileage (5 sections-fixed rate plus rate per mile between SWC)
- Bridging Optional Features (6 applicable, i.e., each port)

In addition, charges for other Optional Features and Functions may be applicable.

** New or Revised*

Continued

DATRE ISSUED: July 31, 2002

EFFECTIVE DATE: September 18, 2002

Aloa J. Stevens
 Director - State Regulatory Affairs
 Citizens Communications Company
 4 Triad Center, Suite 200
 Salt Lake City, UT 84180

 ACCESS SERVICE

7. Special Access Service (Cont'd)7.1 Provision of Special Access Service (Cont'd)7.1.3 Technical Specifications Packages

Information pertaining to the technical specifications packages indicates the transmission parameters that are available with each package. This information is included in each individual service description section in 7.3 through 7.9 following, in a matrix format with the transmission parameters listed down the left side and the packages listed across the top. Each package is identified by a code, e.g., VGC. The first two letters of the code indicate the category of Special Access Service to which the parameters are applicable. These two letter codes are shown above in parentheses following the category of Special Access Service.

The letter "C" following the two letter code indicates the technical specifications package for a customized service. A numeric or alpha-numeric designation following the two letter code indicates the specific predefined package. For a customized service, the customer may select any parameters available with that category of service as long as the parameters are compatible. When appropriate, the Technical Reference which contains detailed specifications for the parameters is shown following the matrix.

All services installed after the effective date of this tariff will conform to the transmission specification standards contained in this tariff or in the following Technical References for each category of service:

Metallic	PUB	62502
Voice Grade	PUB	TR-NPL-000335
	PUB	41004, Table 4

* *New or Revised**Continued*

DATRE ISSUED: July 31, 2002

EFFECTIVE DATE: September 18, 2002

Aloa J. Stevens
 Director - State Regulatory Affairs
 Citizens Communications Company
 4 Triad Center, Suite 200
 Salt Lake City, UT 84180

 ACCESS SERVICE

7. Special Access Service (Cont'd)7.1 Provision of Special Access Service (Cont'd)7.1.3 Technical Specifications Packages (Cont'd)

Program Audio	PUB	62503 and associated Addendum
Video	PUB	62504 and associated Addendum
Wideband Analog	PUB	62505 and associated Addendum
Digital Data	PUB	62507
	PUB	62310
High Capacity	PUB	64508
		62411

The Telephone Company will maintain existing transmission specifications on services installed prior to the effective date of this tariff, except that existing services with performance specifications exceeding the standards listed in this provision will be maintained at those levels until disconnected and all new services will be maintained at the performance levels specified in this tariff.

Customized technical specifications packages will be provided where technically feasible. If the Telephone Company determines that the requested parameter specifications are not compatible, the customer will be advised and given the opportunity to change the order.

7.1.4 Channel Interfaces

Channel interfaces at each point of termination on a two-point service may be symmetrical or asymmetrical. On a multipoint service they may also be symmetrical or asymmetrical, but communications can only be provided between compatible

* *New or Revised**Continued*

DATRE ISSUED: July 31, 2002

EFFECTIVE DATE: September 18, 2002

Aloa J. Stevens
Director - State Regulatory Affairs
Citizens Communications Company
4 Triad Center, Suite 200
Salt Lake City, UT 84180

ACCESS SERVICE

7. Special Access Service (Cont'd)

7.1 Provision of Special Access Service (Cont'd)

7.1.4 Channel Interfaces (Cont'd)

channel interfaces. Only certain channel interfaces are compatible. These are set forth in Section 9 following, in a combination format.

Only certain channel interface combinations are available with the predefined technical specifications packages. These are delineated in the Technical References set forth in 7.1.3 preceding. When a customized circuit is requested, all channel interface combinations available with the specified type of service are available with the customized circuit.

7.1.5 Alternate Use

Alternate Use occurs when a service is arranged by the Telephone Company so that the customer can select different types of transmission at different times. A customer may use a service in any privately beneficial manner. However, where technical or engineering changes are required to effectuate an alternate use, the Telephone Company will make such special arrangements available on an individual case basis.

The arrangement required to transfer the service from one operation to the other (i.e., the transfer relay and control leads) will be rated and provided on an individual case basis and filed in Section 12, Specialized Service or Arrangements. The customer will pay the stated tariff rates for the Access Service rate elements for the service ordered (i.e., Circuit Terminations, Circuit Mileage [as applicable], and Optional Features and Functions [if any]).

** New or Revised*

DATRE ISSUED: July 31, 2002

Continued

EFFECTIVE DATE: September 18, 2002

Aloa J. Stevens
Director - State Regulatory Affairs
Citizens Communications Company
4 Triad Center, Suite 200
Salt Lake City, UT 84180

ACCESS SERVICE

7. Special Access Service (Cont'd)

7.1 Provision of Special Access Service (Cont'd)

7.1.6 Special Facilities Routing

A customer may request that the Special Access used be specially routed. The regulations, rates and charges for Special Facilities Routing are as set forth in Section 11 following.

7.1.7 Design Layout Report

At the customer's request, the Telephone Company will provide the make-up of the facilities and services provided under this tariff as Special Access Service to aid the customer in designing its overall service. The information will be provided to the customer at no charge in the form of a Design Layout Report and will be reissued or updated whenever the described facilities are materially changed.

7.1.8 Acceptance Testing

At the customer's request, the Telephone Company will cooperatively test, at the time of installation and at no additional charge, the following parameters:

- (A) For Voice Grade analog services, acceptance testing will include tests for loss, 3-tone slope, D.C. continuity, operational signaling, C-notched noise, and C-message noise as applicable according to the order for service. Voice Grade services acceptance testing will also include a balance (improved loss) test if the customer has ordered that optional feature.

** New or Revised*

Continued

DATRE ISSUED: July 31, 2002

EFFECTIVE DATE: September 18, 2002

Aloa J. Stevens
Director - State Regulatory Affairs
Citizens Communications Company
4 Triad Center, Suite 200
Salt Lake City, UT 84180

ACCESS SERVICE

7. Special Access Service (Cont'd)

7.1 Provision of Special Access Service (Cont'd)

7.1.8 Acceptance Testing (Cont'd)

- (B) For services other than Voice Grade, acceptance tests will include tests for the parameters applicable to the service as specified by the customer in the order for service.

In addition to the above tests, Additional Cooperative Acceptance Testing and Nonscheduled Testing, as described in Section 8.4 following, are available at the customer's request. All test results will be made available to the customer upon request.

7.2 Rate Categories, Applications, and Regulations

This section contains the specific regulations governing the rates and charges that apply for Special Access.

7.2.1 Rate Categories

The following rate categories apply to Special Access Service:

- Circuit Terminations
- Circuit Mileage
- Optional Features and Functions
- Nonrecurring Charges

These rate categories are described in (A) through (D) following.

(A) Circuit Termination

The Circuit Termination rate category provides for the communications path between a customer designated premise and the serving wire center of that premise. Included as part of the Circuit Termination is a standard

ACCESS SERVICE

7. Special Access Service (Cont'd)

7.2 Rate Categories, Applications, and Regulations (Cont'd)

7.2.1 Rate Categories (Cont'd)

(A) Circuit Termination (Cont'd)

channel interface arrangement which defines the technical characteristics associated with the type of facilities to which the access service is to be connected at the Point of Termination (POT) and the type of signaling capability, if any. The signaling capability itself is provided as an optional feature as set forth in (C) following. One Circuit Termination charge applies per customer designated premises at which the circuit is terminated. This charge will apply even if the customer designated premises and the serving wire center are co-located in a Telephone Company building.

For the avoidance of any doubt when a customer orders Special Access Service to a Telephone Company Switch, that switch is a Customer Designated Premise (CDP) where the Special Access terminates.

(N)
|
(N)

(B) Circuit Mileage

The Circuit Mileage rate category provides for the end office equipment and transmission facilities between serving wire centers and/or Telephone Company hubs. In addition, when Special Access is used in conjunction with Switched Access Service as set forth in Section 6 preceding for Combined Access Service Arrangements, and the end office serving the customer's end user premises is not capable of combining Switched and Special Access or is not a WATS Serving Office, Circuit Mileage is used to extend the Special Access Circuit to a WATS Serving Office or office capable of combining Switched and Special Access Services. The Circuit Mileage charge is composed of a flat monthly charge plus a rate per mile.

Continued

ACCESS SERVICE

7. Special Access Service (Cont'd)

7.2 Rate Categories, Applications, and Regulations (Cont'd)

7.2.1 Rate Categories (Cont'd)

(B) Circuit Mileage (Cont'd)

(1) Fixed Rate

The fixed rate component of Circuit Mileage is applied only once per Circuit Mileage facility and is also applied when two or more customer designated premises are served by a common serving wire center (i.e., mileage is zero). When Special Access is used in conjunction with Switched Access where the customer's end user premises for the Special Access facility is served by a Telephone Company office capable of combining Switching and Special Access Service, or a WATS Serving Office, the fixed rate does not apply.

(2) Per Mile Rate

The mileage to be used to determine the monthly rate for the per mile portion of Circuit Mileage is calculated on the airline distance between the serving wire centers associated with two customer designated premises, between a serving wire center associated with a customer designated premise and a Telephone Company hub, between two Telephone Company hubs, or between a Telephone Company end office and a WATS serving office, or Telephone Company office capable of combining Switched and Special Access Services. The serving wire center associated with a customer designated premise is the serving wire center from which this customer designated premise would normally receive dial tone. The information for mileage calculation and

** New or Revised*

Continued

DATRE ISSUED: July 31, 2002

EFFECTIVE DATE: September 18, 2002

Aloa J. Stevens
Director - State Regulatory Affairs
Citizens Communications Company
4 Triad Center, Suite 200
Salt Lake City, UT 84180

ACCESS SERVICE

7. Special Access Service (Cont'd)

7.2 Rate Categories, Applications, and Regulations (Cont'd)

7.2.1 Rate Categories (Cont'd)

(B) Circuit Mileage (Cont'd)

(2) Per Mile Rate (Cont'd)

serving wire center V & H coordinates are specified in Section 15 of this tariff. Where the calculated miles include a fraction, the value is always rounded up the next full mile.

When hubs are involved, mileage is computed and rates applied separately for each section of the Circuit Mileage, i.e., customer designated premises serving wire center to hub, hub to hub and/or hub to customer designated premises serving wire center.

However, when any service is routed through a hub for purposes other than customer specified bridging or multiplexing (e.g., the Telephone Company chooses to so route for test access purposes), rates will be applied only to the distance calculated between the serving wire centers associated with the customer designated premises.

When more than one Telephone Company is involved in the provision of Special Access Service, the mileage for the per mile component of Circuit Mileage for each Telephone Company is calculated as set forth in Section 2.4.7 preceding.

** New or Revised*

Continued

DATRE ISSUED: July 31, 2002

EFFECTIVE DATE: September 18, 2002

Aloa J. Stevens
Director - State Regulatory Affairs
Citizens Communications Company
4 Triad Center, Suite 200
Salt Lake City, UT 84180

ACCESS SERVICE

7. Special Access Service (Cont'd)

7.2 Rate Categories, Applications, and Regulations (Cont'd)

7.2.1 Rate Categories (Cont'd)

(C) Optional Features and Functions

Optional Features and Functions may be added to a basic circuit service to improve its quality or utility to meet the customer's specific communications requirements. These optional features and functions are identifiable with specific equipment, and represent the end result in terms of performance characteristics which may be obtained. These characteristics may be obtained by using various combinations of equipment. Although the equipment necessary to perform a specified function may be installed at various locations along the path of the service, they will be charged for a single rate element.

Descriptions for each of the available Optional Features and Functions are set forth in Sections 7.3 through 7.9 following. Specific rate applications for multiplexing are set forth in 7.2.4 following.

(D) Nonrecurring Charges

Nonrecurring charges are one-time charges that apply for installation of Special Access Services, installation of optional features and functions, and moves and service rearrangements.

(1) Installation of Service

Nonrecurring charges apply to each service installed. The nonrecurring charges for the installation of service are applied per Circuit Termination.

ACCESS SERVICE

7. Special Access Service (Cont'd)

7.2 Rate Categories, Applications, and Regulations (Cont'd)

7.2.1 Rate Categories (Cont'd)

(D) Nonrecurring Charges (Cont'd)

(2) Installation of Optional Features and Functions

Nonrecurring charges apply for the installation of some of the optional features and functions available with Special Access Service. The charge applies whether the feature or function is installed coincident with the initial installation of service or at any time subsequent to the installation of the service.

The optional features for which installation charges apply are:

- Voice Grade Data Capability
- Voice Grade Telephoto Capability
- Program Audio Gain Conditioning
- Program Audio Stereo
- Wideband Data Transfer Arrangement

(3) Moves

A move involves a change in the physical location of either the customer's premises or a point of termination at the customer's premises. The charges for the move are dependent on whether the move is to a new location within the same building or to a different building.

** New or Revised*

Continued

DATRE ISSUED: July 31, 2002

EFFECTIVE DATE: September 18, 2002

Aloa J. Stevens
Director - State Regulatory Affairs
Citizens Communications Company
4 Triad Center, Suite 200
Salt Lake City, UT 84180

ACCESS SERVICE

7. Special Access Service (Cont'd)

7.2 Rate Categories, Applications, and Regulations (Cont'd)

7.2.1 Rate Categories (Cont'd)

(D) Nonrecurring Charges (Cont'd)

(3) Moves (Cont'd)

(a) Moves Within the Same Building

When the move is to a new location within the same building, the charge for the move will be an amount equal to one half of the nonrecurring (i.e., installation) charge for the service termination affected. There will be no change in the minimum period requirements.

(b) Moves to a Different Building

Moves to a different building will be treated as a discontinuance and a start of service and all associated nonrecurring charges will apply. New minimum period requirements will be established for the new services. The customer will also remain responsible for satisfying all outstanding minimum period charges for the discontinued service.

(4) Service Rearrangements

Service rearrangements are changes to existing (installed) services which may be administrative only in nature, or that involve actual physical change to the service. Changes to pending orders are set forth in Section 5.3.1 preceding.

** New or Revised*

Continued

DATRE ISSUED: July 31, 2002

EFFECTIVE DATE: September 18, 2002

Aloa J. Stevens
Director - State Regulatory Affairs
Citizens Communications Company
4 Triad Center, Suite 200
Salt Lake City, UT 84180

ACCESS SERVICE

7. Special Access Service (Cont'd)

7.2 Rate Categories, Applications, and Regulations (Cont'd)

7.2.1 Rate Categories (Cont'd)

(D) Nonrecurring Charges (Cont'd)

(4) Service Rearrangements (Cont'd)

(a) A charge will not apply to administrative changes as follows:

- Change of customer name,
- Change of customer or customer's end user premises address when the change of address is not a result of a physical relocation of equipment,
- Change in billing data (name, address, or contact name or telephone number),
- Change of agency authorization,
- Change of customer circuit identification,
- Change of billing account number,
- Change of customer test line number,
- Change of customer or customer's end user contact name or telephone number, and
- Change of jurisdiction.

(b) All other service rearrangements will be charged for as follows:

- If the change involves the addition of other customer designated premises to an existing multipoint service, the nonrecurring charge for the Circuit Termination rate element will apply. The charge(s) will apply only for the location(s) that is being added.

** New or Revised*

Continued

DATRE ISSUED: July 31, 2002

EFFECTIVE DATE: September 18, 2002

Aloa J. Stevens
Director - State Regulatory Affairs
Citizens Communications Company
4 Triad Center, Suite 200
Salt Lake City, UT 84180

ACCESS SERVICE

7. Special Access Service (Cont'd)

7.2 Rate Categories, Applications, and Regulations (Cont'd)

7.2.1 Rate Categories (Cont'd)

(D) Nonrecurring Charges (Cont'd)

(4) Service Rearrangements (Cont'd)

(b) (Cont'd)

- If the change involves the addition of an optional feature or function which has a separate nonrecurring charge, that nonrecurring charge will apply.
- If the change involves changing the type of signaling on a Voice Grade service, a charge equal to the Voice Grade Circuit Termination rate element nonrecurring charge will apply. The charge will apply per service termination affected.
- For all other changes, including the addition of optional feature or function without a separate nonrecurring charge, a charge equal to a Circuit Termination rate element nonrecurring charge will apply. Only one such charge will apply per service, per change.

** New or Revised*

Continued

DATRE ISSUED: July 31, 2002

EFFECTIVE DATE: September 18, 2002

Aloa J. Stevens
Director - State Regulatory Affairs
Citizens Communications Company
4 Triad Center, Suite 200
Salt Lake City, UT 84180

ACCESS SERVICE

7. Special Access Service (Cont'd)

7.2 Rate Categories, Applications, and Regulations (Cont'd)

7.2.2 Minimum Periods

The minimum service period for all services except part-time and occasional Video and Program Audio services is one month. The minimum service period for part-time Video and Program Audio Services is one day even though the service will be provided only for the duration of the event specified on the order (e.g., one-half hour, two hours, five hours, etc.).

7.2.3 Application of Daily and Monthly Rates

(A) Daily Rates

Daily rates are recurring rates that apply to each 24 hour period or fraction thereof that a Video or Program Audio Special Access Service provided for part-time or occasional use. For purposes of applying daily rates, the 24 hour period is not limited to a calendar day.

Part-time Program Audio or Video Service ordered on one Access Service Request and provided within a consecutive 30 day period will be charged the daily rate, not to exceed an amount equal to the monthly rate. For each subsequent day or part day, a charge equal to 1/30th of the monthly rate shall apply.

(B) Monthly Rates

Monthly rates are flat recurring rates that apply each month or fraction thereof that a Special Access Service is provided. For billing purposes, each month is considered to have 30 days.

ACCESS SERVICE

7. Special Access Service (Cont'd)

7.2 Rate Categories, Applications, and Regulations (Cont'd)

7.2.4 Facility Hubs and Multiplexing

A customer has the option of ordering Voice Grade facilities or High Capacity facilities (i.e., Group, Supergroup, Mastergroup, DS1, DS1C, DS2, DS3 or DS4) to a facility hub for multiplexing to individual services of a lower capacity or bandwidth (e.g., Telegraph, Voice, etc.). Additionally, the customer may specify optional features for the individual circuits derived from the facility to further tailor the circuit to meet specific communications requirements.

Some of the types of multiplexing available include the following:

- from higher to lower bit rate
- from higher to lower bandwidth
- from digital to voice frequency circuits

A hub is a Telephone Company designated wire center at which multiplexing functions are performed.

Different locations may be designated as hubs for different facility capacities, e.g., multiplexing from digital to digital may occur at one location while multiplexing from digital to analog may occur at a different location. When placing an Access Service Request the customer will specify the desired hub. Section 15 of this tariff identifies serving wire centers, hub locations and the type of multiplexing functions available.

Point to point services may be provided on circuits of these facilities to a hub. The transmission performance for the point to point service provided between the customer designated premises will be that of the lower capacity or bit rate.

** New or Revised*

DATRE ISSUED: July 31, 2002

Continued

EFFECTIVE DATE: September 18, 2002

Aloa J. Stevens
Director - State Regulatory Affairs
Citizens Communications Company
4 Triad Center, Suite 200
Salt Lake City, UT 84180

ACCESS SERVICE

7. Special Access Service (Cont'd)

7.2 Rate Categories, Applications, and Regulations (Cont'd)

7.2.4 Facility Hubs and Multiplexing (Cont'd)

The Telephone Company will commence billing the monthly rate for the facility to the hub on the date specified by the customer on the Access Service Request. The customer will be billed for a High Capacity or Voice Grade Circuit Termination, Circuit Mileage and the multiplexer for the service at the time the facility is installed. Individual services utilizing these facilities may be installed coincident with the installation of the facility to the hub or may be ordered and/or installed at a later date, at the option of the customer. Individual service rates (by service type) will apply for a Circuit Termination and additional Circuit Mileage (as required) for each channelized service. These will be billed to the customer as each individual service is installed.

Cascading multiplexing occurs when a high capacity circuit is demultiplexed to provide circuits with a lesser capacity and one of the lesser capacity circuits is further demultiplexed. When cascading multiplexing is performed, whether in the same or a different hub, a charge for the additional multiplexing unit also applies. When cascading multiplexing is performed at different hubbing locations, Circuit Mileage charges also apply between the hubs.

Although not requiring multiplexing, the Telephone Company will designate certain hubs for Video and Program Audio Services. Full-time service will be provided between a customer designated premise and a hub and billed accordingly at the monthly rates set forth in 16.6.4 and 16.6.5 for a Circuit Termination, and Circuit Mileage and Optional Features and Functions as applicable. The customer may order part-time and occasional Program Audio or Video services as needed between the hub and a second customer designated premise.

** New or Revised*

Continued

DATRE ISSUED: July 31, 2002

EFFECTIVE DATE: September 18, 2002

Aloa J. Stevens
Director - State Regulatory Affairs
Citizens Communications Company
4 Triad Center, Suite 200
Salt Lake City, UT 84180

ACCESS SERVICE

7. Special Access Service (Cont'd)

7.2 Rate Categories, Applications, and Regulations (Cont'd)

7.2.4 Facility Hubs and Multiplexing (Cont'd)

The rate elements required to provide the part-time or occasional service (i.e., Circuit Termination, and Circuit Mileage and Optional Features as applicable) will be billed at daily rates for the duration of the service requested.

7.2.5 Shared Use Analog and Digital High Capacity Services

Shared use refers to a rate application applicable only when the customer orders High Capacity or Wideband Analog facilities between a customer designated premise and a Telephone Company hub where the Telephone Company performs multiplexing/demultiplexing functions and the same customer then orders the derived circuits as Special and Switched Access Services.

The facility will be ordered, provided and rated as Special Access Service (i.e., Circuit Termination, Circuit Mileage, as appropriate, and Multiplexing Arrangement). The nonrecurring charge that applies when the shared use facility is installed will be the nonrecurring charge associated with the appropriate Special Access High Capacity or Wideband Analog Circuit Termination. Rating as Special Access will continue until such time as the customer chooses to use a portion of the available capacity for Switched Access Service. Individual service (i.e., Switched or Special Access) nonrecurring charges will not apply to the individual circuits of the shared use facility.

As each individual circuit is activated for Switched Access Service, the High Capacity or Wideband Analog Special Access Circuit Termination and Circuit Mileage rates will be reduced accordingly (e.g., 1/24th for a DS1 service, etc.). Switched Access Service rates and charges, as set forth in Section 6 preceding, will apply for each circuit of the shared use facility that is used to provide a Switched Access Service.

** New or Revised*

Continued

DATRE ISSUED: July 31, 2002

EFFECTIVE DATE: September 18, 2002

Aloa J. Stevens
Director - State Regulatory Affairs
Citizens Communications Company
4 Triad Center, Suite 200
Salt Lake City, UT 84180

ACCESS SERVICE

7. Special Access Service (Cont'd)

7.2 Rate Categories, Applications, and Regulations (Cont'd)

7.2.5 Shared Use Analog and Digital High Capacity Service (Cont'd)

The customer must place an order for each individual Switched or Special Access Service utilizing the Shared Use Facilities and specify the circuit assignment for each such service.

When Special Access Service is provided utilizing a circuit of the shared use facility to a hub, High Capacity or Wideband Analog rates and charges will apply for the facility to the hub, as set forth preceding, and individual service rates and charges will apply from the hub to the customer designated premises. The rates and charges that will apply to the portion from the hub to the customer designated premises will be dependent on the specific type of Special Access Service that is provided (e.g., Voice Grade, Telegraph, etc.). The applicable rates and charges will include a Circuit Termination and Circuit Mileage, if applicable. Rates and charges for optional features and functions associated with the service, if any, will apply for the appropriate circuit type.

7.3 Metallic Service

7.3.1 Basic Circuit Description

A Metallic circuit is an unconditioned two-wire circuit capable of transmitting low speed varying signals at rates up to 30 baud. Metallic circuits are provided between customer designated premises or between a customer designated premise and a Telephone Company hub where bridging functions are performed. Interoffice metallic facilities will be limited in length to a total of five miles per circuit.

** New or Revised*

Continued

DATRE ISSUED: July 31, 2002

EFFECTIVE DATE: September 18, 2002

Aloa J. Stevens
Director - State Regulatory Affairs
Citizens Communications Company
4 Triad Center, Suite 200
Salt Lake City, UT 84180

ACCESS SERVICE

7. Special Access Service (Cont'd)7.3 Metallic Service (Cont'd)7.3.2 Technical Specifications Packages

<u>Parameter</u>	<u>Package MT-</u>			
	<u>C</u>	<u>1</u>	<u>2</u>	<u>3</u>
D.C. Resistance Between Conductors		X	X	X
Loop Resistance		X		X
Shunt Capacitance		X		X

The technical specifications are delineated in Technical Reference PUB 62502.

7.3.3 Channel Interfaces

Compatible channel interfaces are set forth in Section 9 following.

7.3.4 Optional Features and Functions(1) Central Office Bridging Capability

- (a) Three Premises Bridging - Provision of tip-to-tip and ring-to-ring connection in a central office of a metallic pair to a third customer premise.
- (b) Series Bridging of up to 26 customer premises. The following table shows the technical specifications packages with which the optional features and functions are available.

* *New or Revised**Continued*

DATRE ISSUED: July 31, 2002

EFFECTIVE DATE: September 18, 2002

Aloa J. Stevens
Director - State Regulatory Affairs
Citizens Communications Company
4 Triad Center, Suite 200
Salt Lake City, UT 84180

ACCESS SERVICE

7. Special Access Service (Cont'd)

7.3 Metallic Service (Cont'd)

7.3.4 Optional Features and Functions (Cont'd)

(1) Central Office Bridging Capability (Cont'd)

	<u>Available with Technical Specifications Package MT-</u>			
	<u>C</u>	<u>1</u>	<u>2</u>	<u>3</u>
Three Premises Bridging	X	X		X
Series Bridging	X		X	

** New or Revised*

Continued

DATRE ISSUED: July 31, 2002

EFFECTIVE DATE: September 18, 2002

Aloa J. Stevens
Director - State Regulatory Affairs
Citizens Communications Company
4 Triad Center, Suite 200
Salt Lake City, UT 84180

ACCESS SERVICE

7. Special Access Service (Cont'd)

7.4 Voice Grade Service

7.4.1 Basic Circuit Description

A Voice Grade Circuit is a circuit, which provides voice frequency transmission capability in the nominal frequency range of 300 to 3000 Hz and may be terminated two-wire or four-wire. Effective two-wire and four-wire circuits are available as an Optional Feature and Function. Voice Grade circuits are provided between customer designated premises or between a customer designated premise and a Telephone Company hub.

Voice Grade Service may be ordered in conjunction with Switched Access services as set forth in Section 6 preceding to provide access for a customer's communication service; e.g., WATS, 800, or WATS-type service. When the customer orders the Combined Access Service Arrangement, Voice Grade Circuits provide voice frequency transmission capability between an end user premises and Telephone Company offices capable of combining Special and Switched Access services or between an end user premises and a WATS Serving Office (WSO). All applicable Special Access rates and charges apply (including Optional Features and Functions charges). Technical Specifications, Optional Features and Functions available with this arrangement are indicated under Package VG-CA in 16.6.2 following.

(T)

Continued

DATE ISSUED: May 9, 2012

EFFECTIVE DATE: July 1, 2012

Kenneth Mason
Vice President – Government & Regulatory Affairs
Citizens Communications Company
180 S. Clinton Ave.
Rochester, NY 14646

ACCESS SERVICE

7. Special Access Service (Cont'd)

7.4 Voice Grade Service

7.4.2 Technical Specifications Packages

Parameter	C*	Package VG-												CA		
		1	2	3	4	5	6	7	8	9	10	11	12			
Attenuation																
Distortion	X	X	X	X	X	X	X	X	X	X	X	X	X	X	X	X
C-Message Noise	X	X	X	X	X	X	X	X	X	X	X	X	X	X	X	X
Echo Control	X	X	X	X		X		X	X			X	X	X		
Envelope Delay																
Distortion	X						X	X	X	X	X	X	X	X	X	X
Frequency Shift	X						X	X	X	X	X	X	X	X	X	X
Impulse Noise	X					X	X	X	X	X	X	X	X	X	X	X
Intermodulation																
Distortion	X						X	X	X	X	X	X				X
Loss Deviation	X	X	X	X	X	X	X	X	X	X	X	X	X	X	X	X
Phase Hits, Gain																
Hits, and																
Dropouts	X															
Phase Jitter	X						X	X	X	X	X	X	X	X	X	X
Return Loss																X
Signal-to-C																
Message Noise					X											
Signal-to-C																
Notch Noise	X				X	X	X	X	X	X	X	X	X	X	X	X

The technical specifications for these parameters (except for dropouts, gain hits, and phase hits) are delineated in Technical Reference TR-NPL-000335 and associated Addendum. The technical specifications for dropouts, phase hits, and gain hits are delineated in Technical Reference PUB 41004, Table 4.

* *New or Revised*

Continued

DATRE ISSUED: July 31, 2002

EFFECTIVE DATE: September 18, 2002

Aloa J. Stevens
Director - State Regulatory Affairs
Citizens Communications Company
4 Triad Center, Suite 200
Salt Lake City, UT 84180

ACCESS SERVICE

- * The desired parameters are selected by the customer from the list of available parameters.

** New or Revised*

Continued

DATRE ISSUED: July 31, 2002

EFFECTIVE DATE: September 18, 2002

Aloa J. Stevens
Director - State Regulatory Affairs
Citizens Communications Company
4 Triad Center, Suite 200
Salt Lake City, UT 84180

ACCESS SERVICE

7. Special Access Service (Cont'd)

7.4 Voice Grade Service (Cont'd)

7.4.3 Channel Interfaces

The following channel interfaces for Voice Grade service do not require signaling capability: AH, DA, DB, DD, DE, DS, NO, PR and TF.

The following channel interfaces for Voice Grade service require signaling capability: AB, AC, CT, DX, DY, EA, EB, EC, EX, GO, GS, LA, LB, LC, LO, LR, LS, RV, and SF.

Compatible channel interfaces are set forth in Section 9 following.

7.4.4 Optional Features and Functions

(1) Central Office Bridging Capability

- (a) Voice Bridging (two-wire or four-wire)
- (b) Data Bridging (two-wire or four-wire)
- (c) Telephoto Bridging (two-wire and four-wire)
- (d) Dataphone Select-A-Station Bridging with sequential arrangement ports or addressable arrangement ports
- (e) Telemetry and Alarm Bridging, Split Band-Active Bridging, Passive Bridging, Summation-Active Bridging

ACCESS SERVICE

7. Special Access Service (Cont'd)

7.4 Voice Grade Service (Cont'd)

7.4.4 Optional Features and Functions (Cont'd)

(2) Central Office Multiplexing

Voice to Telegraph Grade: An arrangement that converts a Voice Grade circuit to Telegraph Grade circuits using frequency division multiplexing.

(3) Conditioning

Conditioning provides more specific transmission characteristics for Voice Grade services. C-Type conditioning controls attenuation distortion and envelope delay distortion. Sealing Current helps maintain continuity on dry metallic loops.

For two-point services, the parameters apply to each service. For multipoint services, the parameters apply to each mid link or end link. C-Type conditioning and Data Capability may be combined on the same service.

(a) C-Type Conditioning

C-Type Conditioning is provided for the additional control of attenuation distortion and envelope delay distortion on data services. The attenuation distortion and envelope delay distortion specifications for C-Type Conditioning are:

ACCESS SERVICE

7. Special Access Service (Cont'd)7.4 Voice Grade Service (Cont'd)7.4.4 Optional Features and Functions (Cont'd)(3) Conditioning (Cont'd)(a) C-Type Conditioning (Cont'd)

<u>Attenuation Distortion</u> (Frequency Response) <u>Relative to 1004 Hz</u>		<u>Envelope Delay</u> <u>Distortion</u>	
<u>Frequency</u> <u>Range (Hz)</u>	<u>Variation</u> <u>(dB)</u>	<u>Frequency</u> <u>Range (Hz)</u>	<u>Variation</u> <u>(micro-</u> <u>seconds)</u>
400 - 2800	-1.0 to +2.0	1000-2600	100
300 - 3000	-1.0 to +3.0	800-2600	200
3000 - 3200	-2.0 to +6.0	600-2600	300
		500-2800	600
		500-3000	3000

(b) Sealing Current

Sealing Current Conditioning is provided to help maintain continuity on dry metallic loops. It is usually associated with four-wire DA or NO type channel interfaces.

(4) Customer Specified Premises Receive Level

This option allows the customer to specify the receive level at the Point of Termination. This level must be within a specific range on effective four-wire transmission. The ranges are delineated in Technical Reference TR-NPL-000335.

* *New or Revised**Continued*

DATRE ISSUED: July 31, 2002

EFFECTIVE DATE: September 18, 2002

Aloa J. Stevens
Director - State Regulatory Affairs
Citizens Communications Company
4 Triad Center, Suite 200
Salt Lake City, UT 84180

ACCESS SERVICE

7. Special Access Service (Cont'd)

7.4 Voice Grade Service (Cont'd)

7.4.4 Optional Features and Functions (Cont'd)

(5) Improved Return Loss

- (a) On Effective Four-Wire Transmission at Four-Wire Point of Termination (applicable to each two-wire port): Provides for a fixed 600 ohm impedance, variable level range and simplex reversal. Telephone Company equipment is required at the customer's premises where this option is ordered. The Improved Return Loss parameters are delineated in Technical Reference TR-NPL-000335.
- (b) On Effective Two-Wire Transmission at Two-Wire Point of Termination: Provides for more stringent Echo Control specifications. In order for this option to be applicable, the transmission path must be four-wire at one POT and two-wire at the other POT. Placement of Telephone Company equipment may be required at the customer's premises with the two-wire POT. The Improved Return Loss parameters are delineated in Technical Reference TR-NPL-000335.

(6) Data Capability

Data Capability provides transmission characteristics suitable for data communications. Specifically, Data Capability provides for the control of Signal to C-Notched Noise Ratio and intermodulation distortion. It is available for two-point services or multipoint services.

ACCESS SERVICE

7. Special Access Service (Cont'd)

7.4 Voice Grade Service (Cont'd)

7.4.4 Optional Features and Functions (Cont'd)

(6) Data Capability (Cont'd)

The Signal to C-Notched Noise Ratio and intermodulation distortion parameter for Data Capability are:

- Signal to C-Notched Noise Ratio is greater than or equal to 32 dB
- Intermodulation distortion
- Signal to second order modulation products (R2) is greater than or equal to 38 dB
- Signal to third order modulation products (R3) is greater than or equal to 42 dB.

When a service equipped with Data Capability is used for voice communications, the quality of the voice transmission may not be satisfactory.

(7) Telephoto Capability

Telephoto Capability provides transmission characteristics suitable for telephotographic communications. Specifically, Telephoto Capability is provided for the control of attenuation distortion and envelope delay distortion of telephotographic services. The attenuation distortion and envelope delay distortion parameters for Telephoto Capability are:

** New or Revised*

Continued

DATRE ISSUED: July 31, 2002

EFFECTIVE DATE: September 18, 2002

Aloa J. Stevens
Director - State Regulatory Affairs
Citizens Communications Company
4 Triad Center, Suite 200
Salt Lake City, UT 84180

 ACCESS SERVICE

7. Special Access Service (Cont'd)7.4 Voice Grade Service (Cont'd)7.4.4 Optional Features and Functions (Cont'd)(7) Telephoto Capability (Cont'd)

<u>Attenuation Distortion</u> (1004 Hz Reference)		<u>Envelope Delay Distortion</u>	
<u>Frequency Range (Hz)</u>	<u>Variation (dB)</u>	<u>Frequency Range (Hz)</u>	<u>Variation (mcs)</u>
500-3000	-0.5 to +1.5	1000-2600	110
300-3200	-1.0 to +2.5	800-2800	180

(8) Signaling Capability

Signaling Capability provides for the ability to transmit signals from one customer premise to another customer premise on the same service.

(9) Selective Signaling Arrangement

An arrangement that permits code selective ringing for up to ten codes on a multipoint service.

(10) Transfer Arrangement

An arrangement that affords the customer an additional measure of flexibility in the use of their access circuits. The arrangement can be utilized to transfer a leg of a Special Access Service to another circuit that terminates in either the same or a different customer premise. A

* *New or Revised**Continued*

DATRE ISSUED: July 31, 2002

EFFECTIVE DATE: September 18, 2002

Aloa J. Stevens
Director - State Regulatory Affairs
Citizens Communications Company
4 Triad Center, Suite 200
Salt Lake City, UT 84180

ACCESS SERVICE

7. Special Access Service (Cont'd)

7.4 Voice Grade Service (Cont'd)

7.4.4 Optional Features and Functions (Cont'd)

(10) Transfer Arrangement (Cont'd)

key activated or dial-up control service is required to operate the transfer arrangement. A spare circuit, if required, is not included as part of the option.

(11) Four-Wire/Two-Wire Conversions

The term "Effective Two-Wire" denotes a condition which permits the simultaneous transmission in both directions over a channel, but it is not possible to insure independent information transmission in both directions. Effective two-wire channels may be terminated with two-wire or four-wire interfaces.

The term "Effective Four-Wire" denotes a condition which permits the simultaneous independent transmission of information in both directions over a channel. The method of implementing effective four-wire transmission is at the discretion of the Telephone Company (physical, time domain, frequency-domain separation, or echo cancellation techniques). Effective four-wire channels may be terminated with a two-wire interface at the customer's premises. However, when terminated two-wire, simultaneous independent transmission cannot be supported because the two wire interface combines the transmission paths into a single path.

** New or Revised*

Continued

DATRE ISSUED: July 31, 2002

EFFECTIVE DATE: September 18, 2002

Aloa J. Stevens
Director - State Regulatory Affairs
Citizens Communications Company
4 Triad Center, Suite 200
Salt Lake City, UT 84180

ACCESS SERVICE

7. Special Access Service (Cont'd)

7.4 Voice Grade Service (Cont'd)

7.4.4 Optional Features and Functions (Cont'd)

(11) Four-Wire/Two-Wire Conversions (Cont'd)

When a customer requests that an effective four-wire circuit be terminated with a two-wire circuit interface at the customer designated premises, a four-wire to two-wire conversion is required. The customer will be charged the four-wire Circuit Termination rate when an effective four-wire is specified in the customer's order. The rate for the conversion is included as part of the basic Circuit Termination rate.

** New or Revised*

Continued

DATRE ISSUED: July 31, 2002

EFFECTIVE DATE: September 18, 2002

Aloa J. Stevens
Director - State Regulatory Affairs
Citizens Communications Company
4 Triad Center, Suite 200
Salt Lake City, UT 84180

ACCESS SERVICE

7. Special Access Service (Cont'd)

7.4 Voice Grade Service (Cont'd)

7.4.4 Optional Features and Functions (Cont'd)

The following table shows the technical specifications packages with which the optional features and functions are available.

	Available with Technical Specifications Package VG-													
	<u>C</u>	<u>1</u>	<u>2</u>	<u>3</u>	<u>4</u>	<u>5</u>	<u>6</u>	<u>7</u>	<u>8</u>	<u>9</u>	<u>10</u>	<u>11</u>	<u>12</u>	<u>CA</u>
C-Type Conditioning Central Office	X						X	X	X	X	X	X		
Bridging Capability Central Office	X			X	X	X		X	X	X				
Multiplexing	X							X						
Customer Specified Premises Receive Level		X		X	X				X	X	X			
Data Capability	X							X	X		X			
Improved Return Loss -For Effective Four-Wire Transmission	X	X	X	X	X	X		X	X	X	X	X	X	X
-For Effective Two-Wire Transmission	X	X	X		X							X		
Sealing Current Conditioning		X						X						
Selective Signaling Arrangement		X	X					X	X		X	X	X	
Signaling Capability		X	X	X	X				X	X	X			X
Transfer Arrangement		X	X	X	X	X	X	X	X	X		X	X	X

* New or Revised

Continued

DATRE ISSUED: July 31, 2002

EFFECTIVE DATE: September 18, 2002

Aloa J. Stevens
Director - State Regulatory Affairs
Citizens Communications Company
4 Triad Center, Suite 200
Salt Lake City, UT 84180

ACCESS SERVICE

7. Special Access Service (Cont'd)

7.5 Program Audio Service

7.5.1 Basic Circuit Description

A Program Audio circuit is a circuit measured in Hz for the transmission of a complex signal voltage. The actual bandwidth is a function of the channel interface selected by the customer. The nominal frequency bandwidths are from 50 to 15000 Hz, from 200 to 3500 Hz, from 100 to 5000 Hz or from 50 to 8000 Hz. Only one-way transmission is provided. Program Audio circuits are provided between customer designated premise or between a customer designated premise and a Telephone Company hub.

7.5.2 Technical Specifications Packages

Parameter	Package AP-				
	C*	1	2	3	4
Actual Measured Loss	X	X	X	X	X
Amplitude Tracking	X				
Crosstalk	X	X	X	X	X
Distortion Tracking			X		
Gain/Frequency Distortion	X	X	X	X	X
Group Delay	X				
Noise	X	X	X	X	X
Phase Tracking	X				
Short-Term Gain Stability			X		
Short-Term Loss	X				
Total Distortion	X	X	X	X	X

The technical specifications are delineated in Technical Reference PUB 62503 and associated Addendum.

* The desired parameters are selected by the customer from the list available parameters.

 ACCESS SERVICE

7. Special Access Service (Cont'd)7.5 Program Audio Service (Cont'd)7.5.3 Channel Interfaces

The following channel interfaces (CIs) define the bandwidths that are available for a Program Audio circuit:

<u>CI</u>	<u>Bandwidth</u>
PG-1	Nominal frequency from 50 to 15000 Hz
PG-3	Nominal frequency from 200 to 3500 Hz
PG-5	Nominal frequency from 100 to 5000 Hz
PG-8	Nominal frequency from 50 to 8000 Hz

Compatible channel interfaces are set forth in Section 9 following.

7.5.4 Optional Features and Functions(1) Central Office Bridging Capability

Distribution Amplifier

(2) Gain Conditioning

Control of 1004 Hz AML at initiation of service to 0dB ±
0.5 dB.

(3) Stereo

Provision of a pair of gain/phase equalized channels for stereo applications. (Additional AP channels must be ordered separately.)

The following table shows the technical specifications packages with which the optional features and functions are available.

* *New or Revised**Continued*

DATRE ISSUED: July 31, 2002

EFFECTIVE DATE: September 18, 2002

Aloa J. Stevens
Director - State Regulatory Affairs
Citizens Communications Company
4 Triad Center, Suite 200
Salt Lake City, UT 84180

ACCESS SERVICE

7. Special Access Service (Cont'd)

7.5 Program Audio Service (Cont'd)

7.5.4 Optional Features and Functions (Cont'd)

(3) Stereo (Cont'd)

	Available with Technical Specifications Package AP-				
	<u>C</u>	<u>1</u>	<u>2</u>	<u>3</u>	<u>4</u>
- Central Office Bridging Capability	X	X	X	X	X
- Gain Conditioning	X	X	X	X	X
- Stereo	X				X

** New or Revised*

Continued

DATRE ISSUED: July 31, 2002

EFFECTIVE DATE: September 18, 2002

Aloa J. Stevens
Director - State Regulatory Affairs
Citizens Communications Company
4 Triad Center, Suite 200
Salt Lake City, UT 84180

ACCESS SERVICE

7. Special Access Service (Cont'd)7.6 Video Services7.6.1 Basic Circuit Description

A Video circuit is a circuit with one-way transmission capability for a standard 525 line/60 field monochrome, or National Television Systems Committee color video signal and one or two associated 5 or 15 kHz audio signal(s). The bandwidth for a video circuit is either 30 Hz to 4.5 MHz or 30 Hz to 6.6 MHz. The associated audio signal(s) may be either duplexed or provided as one or two separate circuits. The provision and the bandwidth of the associated audio signal(s) is a function of the channel interface selected by the customer. Video circuits are provided between customer designated premises or between a customer designated premise and a Telephone Company hub.

7.6.2 Technical Specifications Packages

Parameter	Package TV-		
	C*	1	2
Amplitude vs. Frequency Response	X		
Chrominance/Luminance Inequalities			
- Gain	X	X	X
- Delay	X	X	X
Chrominance/Luminance Intermodulation	X		
Chrominance Nonlinear Gain	X		
Chrominance Nonlinear Phase	X		
Crosstalk	X		X
Differential Gain	X	X	X
Differential Phase	X	X	X
Dynamic Gain (picture and sync signal)	X		
Field-Time Distortion	X	X	X
Gain/Frequency Distortion	X	X	X
Gain Stability	X	X	X

* The desired parameters are selected by the customer from the list of available parameters.

* *New or Revised*

Continued

DATRE ISSUED: July 31, 2002

EFFECTIVE DATE: September 18, 2002

Aloa J. Stevens
Director - State Regulatory Affairs
Citizens Communications Company
4 Triad Center, Suite 200
Salt Lake City, UT 84180

ACCESS SERVICE

7. Special Access Service (Cont'd)7.6 Video Services (Cont'd)7.6.2 Technical Specifications Packages (Cont'd)

Parameter (Cont'd)	Package TV-		
	C*	1	2
Insertion Gain	X	X	X
Line-Time Distortion	X	X	X
Long-Time Distortion	X	X	X
Luminance Nonlinearity	X		
Luminance Signal/CCIR			
Weighted Noise	X	X	X
Short-Time Distortion			
2 T Pulse	X	X	X
T - Bar Ringing		X	X
Signal/15 kHz Flat			
Weighted Noise	X	X	X
Signal/Low Frequency Noise		X	
Stereo Gain Difference		X	
Stereo Phase Difference	X	X	
Total Harmonic Distortion	X	X	X
Transient Sync Signal			
Non-Linearity		X	
Video/Audio Delay Difference		X	

The technical specifications are delineated in Technical Reference PUB 62504 and associated Addendum.

* The desired parameters are selected by the customer from the list of available parameters.

** New or Revised*

Continued

DATRE ISSUED: July 31, 2002

EFFECTIVE DATE: September 18, 2002

Aloa J. Stevens
Director - State Regulatory Affairs
Citizens Communications Company
4 Triad Center, Suite 200
Salt Lake City, UT 84180

 ACCESS SERVICE

7. Special Access Service (Cont'd)7.6 Video Services (Cont'd)7.6.3 Channel Interfaces

The following channel interfaces (CIs) define the bandwidth and the provision of the audio signal(s) associated with a Video circuit:

<u>CI</u>	<u>Audio Bandwidth</u>	<u>Provision</u>
2TV6-1	15kHz	1 Channel, duplexed
2TV6-2	15kHz	2 Channels, duplexed
2TV7-1	15kHz	1 Channel, duplexed
2TV7-2	15kHz	2 Channels, duplexed
4TV6-5	5kHz	1 Channel, separate
4TV6-15	15kHz	1 Channel, separate
4TV7-5	5kHz	1 Channel, separate
4TV7-15	15kHz	1 Channel, separate
6TV6-5	5kHz	2 Channels, separate
6TV6-15	15kHz	2 Channels, separate
6TV7-5	5kHz	2 Channels, separate
6TV7-15	15kHz	2 Channels, separate

Compatible channel interfaces are set forth in Section 9 following.

* *New or Revised**Continued*

DATRE ISSUED: July 31, 2002

EFFECTIVE DATE: September 18, 2002

Aloa J. Stevens
 Director - State Regulatory Affairs
 Citizens Communications Company
 4 Triad Center, Suite 200
 Salt Lake City, UT 84180

ACCESS SERVICE

7. Special Access Service (Cont'd)7.7 Wideband Analog Services7.7.1 Basic Circuit Description

A Wideband Analog circuit is a circuit with a bandwidth measured in kHz for the transmission of a wideband signal. The actual bandwidth is a function of the channel interface selected by the customer. The bandwidths are from 60 to 108 kHz (Group), from 312 to 552 kHz (Supergroup), from 564 to 3084 kHz (Mastergroup), from 300 Hz to 18 kHz, from 29 to 44 kHz or from 28 to 44 kHz. Wideband Analog circuits are provided between customer designated premises or between a customer designated premise and a Telephone Company hub.

7.7.2 Technical Specifications Packages

Parameter	Package WA-				
	<u>1</u>	<u>2</u>	<u>2A</u>	<u>3</u>	<u>4</u>
Amplitude Stability X	X				
Background Noise	X	X	X	X	X
Frequency Shift	X	X	X		
Gain/Frequency Characteristics of:					
- Group Connections	X			X	X
- Supergroup Connections	X				
- Mastergroup Connections		X			
Impulse Noise	X	X	X		
Net Loss Variations	X	X	X	X	X
Pilot Slot	X	X	X		
Spurious Single Frequency Tone	X	X	X		

The technical specifications are delineated in Technical Reference PUB 62505 and associated Addendum.

* *New or Revised**Continued*

DATRE ISSUED: July 31, 2002

EFFECTIVE DATE: September 18, 2002

Aloa J. Stevens
Director - State Regulatory Affairs
Citizens Communications Company
4 Triad Center, Suite 200
Salt Lake City, UT 84180

 ACCESS SERVICE

7. Special Access Service (Cont'd)7.7 Wideband Analog Services (Cont'd)7.7.3 Channel Interfaces

The following channel interfaces (CIs) define the bandwidths that are available for a Wideband Analog channel:

<u>CI</u>	<u>Bandwidth</u>
AH-B	60 kHz to 108 kHz (Group)
AH-C	312 kHz to 552 KHz (Supergroup)
AD-D	564 kHz to 3084 kHz (Mastergroup)
WD-1	300 Hz to 18 kHz
WD-2	29 kHz to 44 kHz
WD-3	28 kHz to 44 kHz

Compatible channel interfaces are set forth in Section 9 following.

7.7.4 Optional Features and Functions(A) Central Office Multiplexing(1) Mastergroup to Supergroup

An arrangement that converts a Mastergroup circuit to ten Supergroup circuits using frequency division multiplexing.

(2) Supergroup to Group

An arrangement that converts a Supergroup circuit to five Group circuits using frequency division multiplexing.

ACCESS SERVICE

7. Special Access Service (Cont'd)

7.7 Wideband Analog Services (Cont'd)

7.7.4 Optional Features and Functions (Cont'd)

(A) Central Office Multiplexing (Cont'd)

(3) Group to Voice

An arrangement that converts a Group circuit to twelve Voice Grade circuits using frequency division multiplexing.

(4) Group to DS1

An arrangement that converts two Group circuit to DS1 circuit using analog to digital conversion.

The following table shows the technical specifications packages with which the optional features and functions are available.

	Available with Technical Specifications Package WA-				
	<u>1</u>	<u>2</u>	<u>2A</u>	<u>3</u>	<u>4</u>
Central Office Multiplexing:					
Mastergroup to Supergroup			X		
Supergroup to Group		X			
Group to Voice	X				
Group to DS1*					

* Requires two 60-108 kHz Circuit Terminations and Circuit Mileage, one 1.544 Mbps Circuit Mileage and either a 1.544 Circuit Termination or a DS1 to Voice Multiplexing optional feature, depending on whether the service terminates at a customer's premise or was purchased as a facility, to a Telephone Company hub for multiplexing to Voice Grade.

ACCESS SERVICE

7. Special Access Service (Cont'd)7.8 Digital Data Service7.8.1 Basic Circuit Description

A Digital Data circuit is a circuit for duplex four-wire transmission of synchronous serial data at the rate of 2.4, 4.8, 9.6 or 56 Kbps. The actual bit rate is a function of the channel interface selected by the customer. The circuit provides a synchronous service with timing provided by the Telephone Company through the Telephone Company's facilities to the customer in the received bit stream. Digital Data circuits are only available via Telephone Company designated hubs and are provided between customer designated premises or between a customer designated premise and a Telephone Company hub.

The customer may provide the Channel Service Unit-type equipment or other Network Channel Terminating Equipment associated with the Digital Data circuit at the customer premises. The interim program for interconnection of such equipment is set forth in Technical Reference PUB AS No. 1.

7.8.2 Technical Specifications Packages

<u>Parameter</u>	<u>Package DA</u>			
	<u>1</u>	<u>2</u>	<u>3</u>	<u>4</u>
Error-Free Seconds	X	X	X	X

The Telephone Company will provide a circuit capable of meeting a monthly average performance equal to or greater than 99.875% error-free seconds while the circuit is in service, if it is measured through a CSU equivalent which is designed, manufactured, and maintained to conform with the specifications contained in Technical Reference PUB 62310.

Voltages which are compatible with Digital Data Service are delineated in Technical Reference PUB 62507.

* *New or Revised**Continued*

DATRE ISSUED: July 31, 2002

EFFECTIVE DATE: September 18, 2002

Aloa J. Stevens
Director - State Regulatory Affairs
Citizens Communications Company
4 Triad Center, Suite 200
Salt Lake City, UT 84180

 ACCESS SERVICE

7. Special Access Service (Cont'd)7.8 Digital Data Service (Cont'd)7.8.3 Channel Interfaces

The following channel interfaces (CIs) define the bit rates that are available for a Digital Data circuit.

<u>CI</u>	<u>Bit Rate</u>
DU-24	2.4 Kbps
DU-48	4.8 Kbps
DU-96	9.6 Kbps
DU-56	56.0 Kbps

Compatible channel interfaces are set forth in Section 9 following.

7.8.4 Optional Features and Functions

- (1) Central Office Bridging Capability
- (2) Transfer Arrangement

An arrangement that affords the customer an additional measure of protection and/or flexibility in the use of the customer's access circuit(s) on a 1xN basis. The arrangement can be utilized to transfer a leg of a Special Access Service to either a spare or working circuit that terminates in either the same or a different customer designated premises. This arrangement is only available at a Telephone Company designated hub. A key activated or dial-up control service is required to operate the transfer arrangement. A spare circuit, if required, is not included as a part of the option.

* *New or Revised**Continued*

DATRE ISSUED: July 31, 2002

EFFECTIVE DATE: September 18, 2002

Aloa J. Stevens
 Director - State Regulatory Affairs
 Citizens Communications Company
 4 Triad Center, Suite 200
 Salt Lake City, UT 84180

ACCESS SERVICE

7. Special Access Service (Cont'd)

7.9 High Capacity Services

7.9.1 Basic Circuit Description

A High Capacity circuit is a circuit for the transmission of nominal 64.0 kbps* or 1.544, 3.152, 6.312, 44.736, or 274.176 Mbps isochronous serial data. The actual bit rate is a function of the channel interface selected by the customer. High Capacity circuits are provided between customer designated premises or between a customer designated premise and a Telephone Company hub.

The customer may provide the Network Channel Terminating Equipment associated with the High Capacity circuit at the customer's premises. The interim program for interconnection of such equipment is set forth in Technical Reference PUB AS No. 1.

7.9.2 Technical Specifications Packages

<u>Parameter</u>	<u>Package HC</u>					
	<u>0</u>	<u>1</u>	<u>1C</u>	<u>2</u>	<u>3</u>	<u>4</u>
Error-Free Seconds		X				

A circuit with technical specifications package HC1 will be capable of an error-free second performance of 98.75% over a continuous 24 hour period as measured at the 1.544 Mbps rate through a CSU equivalent which is designed, manufactured, and maintained to conform with the specifications contained in Technical Reference PUB 62411.

* Available only as a circuit of a 1.544 Mbps facility to a Telephone Company Digital Data hub or as a cross connect of two 2.4, 4.8, 9.6, 56.0, or 64.0 kbps circuits of two 1.544 Mbps facilities to a Digital Data hub(s). The customer must provide system and channel assignment data.

 ACCESS SERVICE

7. Special Access Service (Cont'd)7.9 High Capacity Services (Cont'd)7.9.3 Channel Interfaces

The following channel interfaces (CIs) define the bit rates that are available for a High Capacity circuit:

<u>CI</u>	<u>Bit Rate</u>
DS-15*	1.544 Mbps (DS1)
DS-27	274.176 Mbps (DS4)
DS-31	3.152 Mbps (DS1C)
DS-44	44.736 Mbps (DS3)
DS-63	6.312 Mbps (DS2)

Compatible channel interfaces are set forth in Section 9.3.5 following.

7.9.4 Optional Features and Functions(1) Automatic Loop Transfer

The Automatic Loop Transfer provides protection on a 1xN basis against failure of the facilities between a customer designated premise and the wire center serving that premise. Protection is furnished through the use of a switching arrangement that automatically switches to a spare circuit line when a working line fails. The spare circuit is not included as a part of the option. This option requires compatible equipment at both the serving wire center and the customer premises. The customer is responsible for providing the equipment at its premises. Equipment at the customer premises will be provided under tariff only if it existed in the Telephone Company inventory as of November 18, 1983.

* A 64.0 kbps circuit is available as a circuit(s) of a 1.544 Mbps facility to a Telephone Company hub.

ACCESS SERVICE

7. Special Access Service (Cont'd)

7.9 High Capacity Services (Cont'd)

7.9.4 Optional Features and Functions (Cont'd)

(2) Transfer Arrangement

An arrangement that affords the customer an additional measure of flexibility in the use of the customer's access circuit(s). The arrangement can be utilized to transfer a leg of a Special Access Service to either a spare or working circuit that terminates in either the same or a different customer designated premise. A key activated or dial-up control service is required to operate the transfer arrangement. A spare circuit, if required, is not included as part of the option.

(3) Central Office Multiplexing

(a) DS4 to DS1

An arrangement that converts a 274.176 Mbps circuit to 168 DS1 circuits using digital time division multiplexing.

(b) DS3 to DS1

An arrangement that converts a 44.736 Mbps circuit to 28 DS1 circuits using digital time division multiplexing.

(c) DS2 to DS1

An arrangement that converts a 6.312 Mbps circuit to four DS1 circuits using digital time division multiplexing.

** New or Revised*

Continued

DATRE ISSUED: July 31, 2002

EFFECTIVE DATE: September 18, 2002

Aloa J. Stevens
Director - State Regulatory Affairs
Citizens Communications Company
4 Triad Center, Suite 200
Salt Lake City, UT 84180

ACCESS SERVICE

7. Special Access Service (Cont'd)

7.9 High Capacity Services (Cont'd)

7.9.4 Optional Features and Functions (Cont'd)

(3) Central Office Multiplexing (Cont'd)

(d) DS1C to DS1

An arrangement that converts a 3.152 Mbps circuit to two DS1 circuits using digital time division multiplexing.

(e) DS1 to Voice

An arrangement that converts a 1.544 Mbps circuit to 24 circuits for use with Voice Grade Services. A circuit at this DS1 to the hub can also be used for a Digital Data Service.

(f) DS1 to DS0

An arrangement that converts a 1.544 Mbps circuit to 23 64.0 kbps circuits utilizing digital time division multiplexing.

(g) DS0 to Subrate

An arrangement that converts a 64.0 kbps circuit to subspeeds of up to twenty 2.4 kbps, ten 4.8 kbps, or five 9.6 kbps circuits using digital time division multiplexing.

** New or Revised*

Continued

DATRE ISSUED: July 31, 2002

EFFECTIVE DATE: September 18, 2002

Aloa J. Stevens
Director - State Regulatory Affairs
Citizens Communications Company
4 Triad Center, Suite 200
Salt Lake City, UT 84180

ACCESS SERVICE

7. Special Access Service (Cont'd)

7.9 High Capacity Services (Cont'd)

7.9.4 Optional Features and Functions (Cont'd)

(3) Central Office Multiplexing (Cont'd)

(g) DSO to Subrate (Cont'd)

The following table shows the technical specifications packages with which the optional features and functions are available.

	Available with Technical Specifications Package HC-					
	<u>0</u>	<u>1</u>	<u>1C</u>	<u>2</u>	<u>3</u>	<u>4</u>
Automatic Loop Transfer		X				
Central Office Multiplexing:						
DS4 to DS1						X
DS3 to DS1					X	
DS2 to DS1				X		
DS1C to DS1			X			
DS1 to Voice		X				
DS1 to DS0		X				
DS0 to Subrate*	X					
Transfer Arrangement		X				

* Available only on a circuit of a 1.544 Mbps facility to a Telephone Company hub.

** New or Revised*

Continued

DATRE ISSUED: July 31, 2002

EFFECTIVE DATE: September 18, 2002

Aloa J. Stevens
Director - State Regulatory Affairs
Citizens Communications Company
4 Triad Center, Suite 200
Salt Lake City, UT 84180

ACCESS SERVICE

** New or Revised*

Continued

DATRE ISSUED: July 31, 2002

EFFECTIVE DATE: September 18, 2002

Aloa J. Stevens
Director - State Regulatory Affairs
Citizens Communications Company
4 Triad Center, Suite 200
Salt Lake City, UT 84180

 ACCESS SERVICE

8. Miscellaneous Services

In this section normally scheduled working hours are an employee's scheduled work period in any given calendar day (e.g., 7:00 a.m. to 4:00 p.m.) for the application of rates based on working hours. Basic Time is that time during normally scheduled working hours. Overtime is that time outside of normally scheduled working hours. Premium Time is that time outside of normally scheduled working days.

A call-out of a Telephone Company employee at a time not consecutive with the employee's scheduled work period is subject to a minimum charge of four hours. Work subject to Premium Time is always subject to a minimum charge of four hours.

8.1 Additional Engineering

Additional Engineering will be provided by the Telephone Company at the request of the customer or when the Telephone Company determines that Additional Engineering is necessary to accommodate a customer's request.

Additional Engineering is provided when:

- (A) A customer requests additional technical information beyond that normally included by the Telephone Company on the Design Layout Report (DLR) as set forth in Section 6. (T)
- (B) Additional Engineering time is incurred by the Telephone Company to engineer a customer's specific written request for a customized service or Additional Engineering activities which are not normally performed in the provision of services under this tariff.

The Telephone Company will notify the customer that Additional Engineering charges, as set forth in 16.7

following, will apply before any additional engineering is undertaken. When it is required, the customer will be so notified and will

Continued

 DATE ISSUED: May 9, 2012

EFFECTIVE DATE: July 1, 2012

Kenneth Mason
 Vice President – Government & Regulatory Affairs
 Citizens Communications Company
 180 S. Clinton Ave.
 Rochester, NY 14646

ACCESS SERVICE

8. Miscellaneous Services (Cont'd)8.1 Additional Engineering (Cont'd)

(B) (Cont'd)

be furnished with a written statement setting forth the justification for the Additional Engineering as well as an estimate of the charges. If the customer agrees to the Additional Engineering, a firm order will be established. If the customer does not want the service or facilities after being notified that Additional Engineering of Telephone Company facilities is required, the order will be withdrawn and no charges will apply. Once a firm order has been established, the total charge to the customer for the Additional Engineering may not exceed the estimated amount by more than 10%.

8.2 Additional Labor

Additional labor is that labor requested and authorized by the customer on a given service and agreed to by the Telephone Company as set forth in 8.2.1 through 8.2.5 following. The Telephone Company will notify the customer that additional labor charges as set forth in 16.7 following will apply before any additional labor is undertaken.

** New or Revised**Continued*

DATE ISSUED: July 31, 2002

EFFECTIVE DATE: September 18, 2002

Aloa J. Stevens
Director – State Government Affairs
Citizens Communications Company
4 Triad Center, Suite 200
Salt Lake City, Utah 84180

ACCESS SERVICE

8. Miscellaneous Services (Cont'd)8.2 Additional Labor (Cont'd)8.2.1 Overtime Installation

Overtime installation is that Telephone Company installation effort performed outside of normally scheduled working hours.

8.2.2 Overtime Repair

Overtime repair is that Telephone Company maintenance effort performed outside of normally scheduled working hours.

8.2.3 Stand By

Stand by includes all time in excess of one-half (1/2) hour during which Telephone Company personnel stand by to make installation acceptance tests or cooperative tests with a customer on a given service.

8.2.4 Maintenance with Other Telephone Companies

Additional labor charges apply to additional maintenance or repair of facilities which connect to facilities of other telephone companies. This is in addition to the normal efforts required to maintain or repair facilities provided solely by the Telephone Company, as set forth in Section 2.1.1(C) preceding.

8.2.5 Other Labor

Other labor is that additional labor not included in 8.2.1 through 8.2.4 preceding. This includes labor incurred to accommodate a specified customer request that involves only labor which is not covered by any other section of this tariff.

* *New or Revised*

Continued

DATE ISSUED: July 31, 2002

EFFECTIVE DATE: September 18, 2002

Aloa J. Stevens
Director – State Government Affairs
Citizens Communications Company
4 Triad Center, Suite 200
Salt Lake City, Utah 84180

ACCESS SERVICE

8. Miscellaneous Services (Cont'd)

8.3 Maintenance of Service

- (A) The customer will be responsible for reporting troubles sectionalized to Telephone Company facilities and/or equipment. When trouble cannot be clearly sectionalized to the Telephone Company facilities and/or equipment, the Telephone Company will test cooperatively or independently to assist in trouble sectionalization.

When a customer reports a trouble to the Telephone Company for clearance and no trouble is found in the Telephone Company's facilities, the customer shall be responsible for payment of a Maintenance of Service charge for the period of time from when Telephone Company personnel are dispatched to the customer's or customer's end user premises to when the work is completed. Failure of Telephone Company personnel to find trouble in Telephone Company facilities will result in no charge if the trouble is actually in those facilities, but not discovered at the time.

** New or Revised*

Continued

DATE ISSUED: July 31, 2002

EFFECTIVE DATE: September 18, 2002

Aloa J. Stevens
Director – State Government Affairs
Citizens Communications Company
4 Triad Center, Suite 200
Salt Lake City, Utah 84180

ACCESS SERVICE

8. Miscellaneous Services (Cont'd)

8.3 Maintenance of Service (Cont'd)

(B) The customer shall be responsible for payment of a Maintenance of Service charge when the Telephone Company dispatches personnel to the customer's premises, and the trouble is in equipment or communications systems provided by other than the Telephone Company or in detariffed CPE provided by the Telephone Company.

In either (A) or (B) preceding, no credit allowance will be applicable for the interruption involved if the Maintenance of Service Charge applies.

(C) The charge for Maintenance of Service are as follows:

Maintenance
Of Service Periods
Per occurrence

Per Technician
The charges for
Maintenance of Service are
the same as those set for
Additional Labor as set forth
in 8.2 preceding.

8.4 Additional Testing

Testing Services provides for the use of a Telephone Company technician in performing specific tests authorized by the customer including additional testing of facilities, which connect to facilities of other telephone companies. Testing Services offered under this section of the tariff are optional and are in addition to acceptance tests and in-service tests performed by the Telephone Company as described in Section 6 preceding. Testing Services are made subject to the availability of the necessary qualified personnel and test equipment at the requested test locations. (T)

Continued

DATE ISSUED: May 9, 2012

EFFECTIVE DATE: July 1, 2012

Kenneth Mason
Vice President – Government & Regulatory Affairs
Citizens Communications Company
180 S. Clinton Ave.
Rochester, NY 14646

ACCESS SERVICE

8. Miscellaneous Services (Cont'd)8.4 Additional Testing (Cont'd)

Testing Services consist of Additional Cooperative Acceptance Testing (ACAT) which is performed during installation of Access Services and Nonscheduled Testing (NST) which is performed after acceptance of Access Services by the customer. Rates and charges for Testing Service are set forth in 16.7.3 following.

The Telephone Company will provide, upon request, documentation that lists the results of the tests performed. Trunk test failures requiring customer participation for trouble resolution will be provided to the customer on an as-occurs basis.

(A) Additional Cooperative Acceptance Testing

Rates and charges for Additional Cooperative Acceptance Testing of Switched and Special Access Services apply per technician used.

(1) Switched Access Service

Additional Cooperative Acceptance Testing (ACAT) of Switched Access Service is performed at the time of installation and involves the Telephone Company provision of a technician at its office(s) and the customer provides a technician at its premises, with suitable test equipment to perform the required tests. The Telephone Company may, at the request of the customer, supply a technician at the customer's premises to perform the required tests.

Additional Cooperative Acceptance Testing may, for example, consist of the following tests:

- C-Notched Noise
- Impulse Noise
- Phase Jitter

ACCESS SERVICE

8. Miscellaneous Services (Cont'd)8.4 Additional Testing (Cont'd)(A) Additional Cooperative Acceptance Testing (Cont'd)(1) Switched Access Service (Cont'd)

- Signal to C-Notched Noise Ratio
- Intermodulation Distortion (Nonlinear)
- Frequency Shift (Offset)
- Envelope Delay Distortion
- Dial Pulse Percent Break

(2) Special Access Service

When a customer provides a technician at its premises or at an end user's premises, with suitable test equipment to perform the requested tests, the Telephone Company may provide a technician at its office for the purpose of conducting Additional Cooperative Acceptance Testing on Voice Grade Services at the time of installation. At the customer's request, the Telephone Company may provide a technician at the customer's premises or at the end user premises: These tests may, for example, consist of the following:

- Attenuation Distortion (i.e., frequency response)
- Intermodulation Distortion (i.e., harmonic distortion)
- Phase Jitter
- Impulse Noise
- Envelope Delay Distortion
- Echo Control
- Frequency Shift

** New or Revised**Continued*

DATE ISSUED: July 31, 2002

EFFECTIVE DATE: September 18, 2002

Aloa J. Stevens
Director – State Government Affairs
Citizens Communications Company
4 Triad Center, Suite 200
Salt Lake City, Utah 84180

ACCESS SERVICE

8. Miscellaneous Services (Cont'd)8.4 Additional Testing (Cont'd)(B) Nonscheduled Testing

Nonscheduled tests are performed by the Telephone Company "on demand." When a customer provides a technician at its premises with suitable test equipment to perform the required tests, the Telephone Company may provide a technician at its office for the purpose of conducting Nonscheduled Testing of Switched or Special Access services. At the customer's request, the Telephone Company may provide a technician at the customer's premises. Nonscheduled tests may consist of any tests, for example, on loss, noise, slope, envelope delay, which the customer may require. Rates and charges for Nonscheduled Testing apply per technician used.

8.5 Presubscription

Presubscription is an arrangement whereby an end user may select and designate to the Telephone Company an IC to access, with 1+ as an access code, for interLATA calls. This IC is referred to as the end user's predesignated IC.

** New or Revised**Continued*

DATE ISSUED: July 31, 2002

EFFECTIVE DATE: September 18, 2002

Aloa J. Stevens
Director – State Government Affairs
Citizens Communications Company
4 Triad Center, Suite 200
Salt Lake City, Utah 84180

ACCESS SERVICE

8. Miscellaneous Services (Cont'd)

8.5 Presubscription (Cont'd)

The regulations and charges pertaining to Presubscription are set forth in FCC Docket 83-1145, Phase I, Memorandum Opinion and Order, Appendix B, adopted by the Federal Communications Commission on May 31, 1985 and released on June 12, 1985. A copy of the Order with all Appendices is available for inspection in the Public Reference Room of the Tariff Division at the main building of the Federal Communications Commission and can also be obtained from the FCC's commercial contractor. Regulations and charges for Presubscription set forth in this section are in compliance with the Order. Charges can be found in 16.7.

(A) End User Notification and Balloting Procedure

Approximately 90 days prior to the introduction of equal access (Feature Group D) in a serving end office, the Telephone Company will notify all affected end users of the availability of equal access. The end user will be directed to designate a primary IC by the use of an equal access ballot to be returned to the Telephone Company within approximately 30 days after the mailing date. An end user has the option of independently contacting the IC to make arrangements for presubscription to the IC's service.

The equal access ballot will include all the names of ICs participating in the presubscription process. ICs are required to place an order for Feature Group D in accordance with the regulations set forth in Section 6 preceding.

(T)

The end user may select only one primary IC for each access line or multiline hunt group through the ballot process. Multiline hunt group end users will be given the opportunity to select more than one primary IC by contacting the Telephone Company. Customers may designate that they do not want a primary IC by notifying the Telephone Company. This choice is considered a valid selection and the nonrecurring charge as set forth in (E)(1) following will apply to any subsequent change made after the equal access conversion date.

Continued

DATE ISSUED: May 9, 2012

EFFECTIVE DATE: July 1, 2012

Kenneth Mason
Vice President – Government & Regulatory Affairs
Citizens Communications Company
180 S. Clinton Ave.
Rochester, NY 14646

ACCESS SERVICE

8. Miscellaneous Services (Cont'd)8.5 Presubscription (Cont'd)(A) End User Notification and Balloting Procedure (Cont'd)

New end users who are served by end offices equipped with Feature Group D will be required to presubscribe to an IC at the time they place an order with the Telephone Company for Telephone Exchange Service. A confirmation notice will be sent to end users who verbally place an order for service identifying the IC selected. There will be no charge for this initial selection. New end users will have 30 days from the date the initial selection is made to change their choice of an IC without charge.

(B) Allocation Process

End users who do not return their initial ballot will receive a second ballot indicating that they have been preassigned to a specific IC. The Telephone Company will assign non-presubscribed end users randomly to the participating ICs in the same proportion as the presubscribed end users based on the results of the initial balloting process as set forth in (A) preceding. Separate allocation processes will be used for residence and business lines.

End users who do not return the second ballot by the specified due date will be presubscribed to the IC indicated on that ballot effective with the equal access conversion. Allocated customers will have 6 months after the equal access conversion date to change to an IC of their choice without charge.

** New or Revised**Continued*

DATE ISSUED: July 31, 2002

EFFECTIVE DATE: September 18, 2002

Aloa J. Stevens
Director – State Government Affairs
Citizens Communications Company
4 Triad Center, Suite 200
Salt Lake City, Utah 84180

ACCESS SERVICE

8. Miscellaneous Services (Cont'd)8.5 Presubscription (Cont'd)(C) IC Customer Lists

The Telephone Company will accept from the IC a list(s) of end users that have made individual arrangements with that IC to become their primary IC. The IC must submit a Telephone Company end user enrollment form listing these end users. The end user enrollment form must be accompanied by a document affirming that the IC does, in fact, have, or has instituted steps designed to obtain, signed letters of agency from the end users designating the IC to act as the end user's agent for the presubscription process. The IC will accept responsibility for any billing disputes arising from implementation of its end user lists.

(D) End User Choice Discrepancies

In the event of discrepancy between an end user's ballot and an IC's end user enrollment form, the Telephone Company will notify, within 10 days, all affected ICs via a conflict report. If the IC certifies to the Telephone Company that it has a signed letter of agency from the end user with a date subsequent to that on the ballot, that IC becomes the primary IC for that end user. If the IC is unable to obtain a letter of agency signed by the end user, the IC selected on the end user's ballot will be used.

When two or more enrollment forms are received from different ICs, and no ballot is returned, the end user in question will be included in the allocation process and will be notified, via the second ballot, that a conflict exists. In addition, the ICs will be notified in this instance. If the conflict is discovered after allocation has taken place, the subscriber in question will be contacted by the Telephone Company to obtain a valid selection.

ACCESS SERVICE

8. Miscellaneous Services (Cont'd)8.5 Presubscription (Cont'd)(E) Presubscription Charge

The nonrecurring charge for Presubscription will be applied as follows:

- (1) After the end office equal access conversion date, for any change in the end user's selection of a primary IC, a nonrecurring charge as set forth in (5) following will apply to the end user. The nonrecurring charge for Presubscription does not apply to any change in selection of a primary IC made prior to the equal access conversion date.
- (2) An allocated end user may use the second ballot as described in (B) preceding or contact the Telephone Company to make an IC selection after allocation has taken place. There will be no charge for this selection if it is done within 6 months after the equal access conversion date.
- (3) Changes in an end user's primary IC made as a result of the resolution of an end user choice discrepancy, as set forth in (D) preceding, will not incur the nonrecurring charge, provided the change is made within 6 months after the equal access conversion date.
- (4) An IC will be charged the Presubscription Charge if the IC submits a request for a change in an end user's primary IC, the end user disputes that request, and the IC is unable to produce a signed letter of agency from the end user designating that IC as the end user's primary IC. End users will not be charged the Presubscription Charge

* *New or Revised*

Continued

DATE ISSUED: July 31, 2002

EFFECTIVE DATE: September 18, 2002

Aloa J. Stevens
Director – State Government Affairs
Citizens Communications Company
4 Triad Center, Suite 200
Salt Lake City, Utah 84180

ACCESS SERVICE

8. Miscellaneous Services (Cont'd)8.5 Presubscription (Cont'd)(E) Presubscription Charge (Cont'd)

(4) (Cont'd)

for any changes made as a result of an error on the part of the IC or the Telephone Company.

- (5) If an IC elects to discontinue all of its Feature Group D service in the converting end office prior to the conversion date or within two years after the introduction of Feature Group D in the converting end office, the IC must notify in writing all end users who have selected or been allocated to that IC, inform these end users of the cancellation, request the end users to select a new IC and state that the canceling IC will pay for the change charge. For a period of two years from the discontinuance of FGD service the Telephone Company will bill a canceling IC the nonrecurring charge as set forth in (6) following for each end user the IC currently has designated to it.

8.6 Miscellaneous Equipment(A) Controller Arrangement

This arrangement enables the customer to control up to 48 transfer functions at a Telephone Company central office via a remote keyboard terminal capable of either 300 or 1200 bps operation. Included as part of the Controller Arrangement is a dial-up data station located at the Telephone Company Central Office to provide access to the Controller Arrangement. This dial-up data station consists of a 212A DATAPHONE data set and an appropriate Telephone Company provided channel.

The Controller Arrangement must be located in the same Telephone Company central office as the transfer functions which it controls, and the charge can be found in Section 16.7.

ACCESS SERVICE

8. Miscellaneous Services (Cont'd)8.7 Telecommunications Service Priority

(T)

TSP System shall be provided in accordance with the guidelines set forth in "Telecommunications Service Priority (TSP) System for National Security Emergency Preparedness (NSEP) Service Vendor Handbook" (NCSH 3-1-2) dated July 9, 1990, and "Telecommunications Service Priority System for National Security Emergency Preparedness Service User Manual" (NCSM 3-1-1).

(N)

No charge applies when a TSP Service is discontinued or when ordered coincident with an access order to install service. The Utility will arrange a TSP Access Service upon receipt of certification as authorized by Part 64, Subset D, Appendix A of the Federal Communications Rules and Regulations.

(A) Regulations

- (1) The TSP System's applicability is limited to telecommunication services, which the Utility can discretely identify for priority provisioning and/or restoration.
- (2) The customer subscribing to TSP System must also be the customer subscribing to the service with which TSP is associated.
- (3) Under certain conditions, it may be necessary to preempt one or more customer services with a lower or no restoration priority in order to install or restore higher priority NSEP telecommunications service(s). If such preemption is necessary, and if circumstances permit, the Utility will make reasonable effort to notify the preempted customer of the action to be taken. Credit allowance for such service preemption shall be made, in accordance with the provisions specified elsewhere in the Utility's Tariff.
- (4) In obtaining TSP System, the customer acknowledges and consents to the Utility providing customer service record information to the Federal Government in order for the Government to maintain and administer its overall TSP System. This customer service record information will include the TSP Authorization Code, Utility's Circuit/Service ID, customer's telephone number and service location.

(N)

(L) Item 8.8 relocated to Sheet No. 409.2.

** New or Revised**Continued*

DATE ISSUED: June 13, 2007

EFFECTIVE DATE: July 13, 2007

Aloa J. Stevens
 Director – Government & External Affairs
 Citizens Communications Company
 P.O. Box 708970
 Sandy, Utah 84070

ACCESS SERVICE

8. Miscellaneous Services (Cont'd)

8.7 Telecommunications Service Priority (Continued)

(N)

(A) Regulations (Continued)

- (5) Credit allowance for service interruption for Priority Restoration Maintenance and Administration shall be the same as for the service with which it is associated as specified elsewhere in the Utility's Tariff.
- (6) When performing a service under TSP, the Utility may not be in a position to notify the customer in advance of circumstances which require additional labor and for which additional labor charges apply. The TSP subscriber recognizes that quoting charges and obtaining permission to proceed would cause unnecessary delays that would be contrary to the objectives of the TSP System. In subscribing to the TSP System the customer recognizes this condition and grants the Utility the right to quote charges after work has been completed.
- (7) Other regulations, rates and charges for services such as expedited service, special construction, due date change, Maintenance of Service etc. may apply as specified elsewhere in the Utility's Tariff when provided in conjunction with the TSP System.

(N)

** New or Revised*

Continued

DATE ISSUED: June 13, 2007

EFFECTIVE DATE: July 13, 2007

Aloa J. Stevens
 Director – Government & External Affairs
 Citizens Communications Company
 P.O. Box 708970
 Sandy, Utah 84070

ACCESS SERVICE

8. Miscellaneous Services (Cont'd)8.8 Standard Jacks - Registration Program

(T)(L)

Standard jacks are provided by the Telephone Company to connect Registered Equipment to those services that are subject to the Registration Program as set forth in Section 2.5 preceding. The use of jacks is covered in Part 68 of the FCC's Rules and Regulations. Specific jacks are described in the document on file with the FCC entitled "Descriptions of Standard Registration Program Connection Configurations Supplementing Configurations Described in Subpart F of Part 68 of FCC's Rules and Regulations."

These jacks are used to terminate services provided by the Telephone Company. Other services or facilities provided by the Telephone Company or by others may also be terminated in any space capacity of the jacks remaining after installation without additional charge for the use of such capacity.

The nonrecurring charges, which include installation, for standard jacks and their typical uses, can be found in Section 16.

(L)

(L) Material formerly located on Sheet No. 409.

** New or Revised**Continued*

DATE ISSUED: June 13, 2007

EFFECTIVE DATE: July 13, 2007

Aloa J. Stevens
Director – Government & External Affairs
Citizens Communications Company
P.O. Box 708970
Sandy, Utah 84070

ACCESS SERVICE

9. Interface Groups, Transmission Specifications, and Channel Codes

9.1 Local Transport Interface Groups

Ten Interface Groups are provided for terminating the Local Transport at the customer's premises. Each Interface Group provides a specified premises interface code (e.g., two-wire, four-wire, DS1, etc.). At the option of the customer and where transmission facilities permit, the individual transmission path between the customer's premises and the first point of switching may be provided with optional features as set forth in Section 6 (T) preceding.

As a result of the customer's access order and the type of Telephone Company transport facilities serving the customer's premises, the need for signaling conversions or two-wire to four-wire conversions, or the need to terminate digital or high frequency facilities in channel bank equipment may require that Telephone Company equipment be placed at the customer's premises. For example, if a voice frequency interface is ordered by the customer and the Telephone Company facilities serving the customer's premises are digital, then Telephone Company channel bank equipment must be placed at the customer's premises in order to provide the voice frequency interface ordered by the customer.

Interface Group 1 is provided with Type C Transmission Specifications, and Interface Groups 2 through 10 are provided with Type A or B Transmission Specifications, depending on the Feature Group and whether the Access Service is routed directly or through an access tandem. All Interface Groups are provided with Data Transmission Parameters.

Only certain premises interfaces are available at the customer's premises. The premises interface codes associated with the Interface Groups may vary among Feature Groups. The various premise interface codes which are available with the Interface Groups, and the Feature Groups with which they may be used, are set forth in 9.1.11 following.

Continued

DATE ISSUED: May 9, 2012

EFFECTIVE DATE: July 1, 2012

Kenneth Mason
Vice President – Government & Regulatory Affairs
Citizens Communications Company
180 S. Clinton Ave.
Rochester, NY 14646

ACCESS SERVICE

9. Interface Groups, Transmission Specifications, and Channel Codes (Cont'd)

9.1 Local Transport Interface Groups (Cont'd)

For each of the ten Interface Groups described following, the transmission path between the point of termination at the customer's premises and the first point of switching may be comprised of any form or configuration of plant and equipment capable of and typically used in the telecommunications industry for the transmission of voice and associated telephone signals within the frequency bandwidth of 300 to 3000 Hz.

9.1.1 Interface Group 1

Interface Group 1 provides a two-wire voice frequency transmission path at the point of termination at the customer's premises. Interface Group 1 is not provided in association with FGC and FGD when the first point of switching is an access tandem. In addition, Interface Group 1 is not provided in association with FGB, FGC or FGD when the first point of switching can only provide four-wire terminations.

The interface is provided with loop supervisory signaling. When the interface is associated with FGA, such signaling will be loop start or ground start signaling. When the interface is associated with FGB, FGC or FGD, such signaling will be reverse battery signaling. When FGB, FGC, or FGD access service is associated with a two-way calling interface, E&M signaling shall be used.

9.1.2 Interface Group 2

Interface Group 2 provides four-wire voice frequency transmission at the point of termination at the customer's premises. The interface is provided with loop supervisory signaling. When the interface is associated with FGA, such signaling will be loop start or ground start signaling. When the

** New or Revised*

Continued

DATE ISSUED: July 31, 2002

EFFECTIVE DATE: September 18, 2002

Aloa J. Stevens
Director – State Government Affairs
Citizens Communications Company
4 Triad Center, Suite 200
Salt Lake City, Utah 84180

ACCESS SERVICE

9. Interface Groups, Transmission Specifications, and Channel Codes (Cont'd)

9.1 Local Transport Interface Groups (Cont'd)

9.1.2 Interface Group 2 (Cont'd)

interface is associated with FGB, FGC or FGD, such signaling, except for two-way calling which is E&M signaling, will be reverse battery signaling.

9.1.3 Interface Group 3

Interface group 3 provides group level analog transmission at the point of termination at the customer's premises. The interface is capable of transmitting electrical signals between the frequencies of 60 to 180 kHz, with the capability to channelize up to 12 voice frequency transmission paths. Certain frequencies within the bandwidth of the Interface Group are reserved for Telephone Company use, e.g., pilot and carrier group alarm tones. Before the first point of switching, the Telephone Company will provide multiplex equipment to derive 12 transmission paths with a frequency bandwidth of approximately 300 to 3000 Hz.

The interface is provided with SF supervisory signaling for each individual transmission channel.

9.1.4 Interface Group 4

Interface group 4 provides supergroup level analog transmission at the point of termination at the customer's premises. The interface is capable of transmitting electrical signals between the frequencies of 312 to 552 kHz, with the capability to channelize up to 60 voice frequency transmission paths. Certain frequencies within the bandwidth of the Interface Group are reserved for Telephone Company use, e.g., pilot and carrier group alarm tones. Before the first point of

** New or Revised*

Continued

DATE ISSUED: July 31, 2002

EFFECTIVE DATE: September 18, 2002

Aloa J. Stevens
Director – State Government Affairs
Citizens Communications Company
4 Triad Center, Suite 200
Salt Lake City, Utah 84180

ACCESS SERVICE

9. Interface Groups, Transmission Specifications, and Channel Codes (Cont'd)

9.1 Local Transport Interface Groups (Cont'd)

9.1.4 Interface Group 4 (Cont'd)

switching, the Telephone Company will provide multiplex and channel bank equipment to derive 60 transmission paths with a frequency bandwidth of approximately 300 to 3000 Hz.

The interface is provided with SF supervisory signaling for each individual transmission channel.

9.1.5 Interface Group 5

Interface Group 5 provides mastergroup level analog transmission at the point of termination at the customer's premises. The interface is capable of transmitting electrical signals between the frequencies of 564 to 3084 kHz, with the capability to channelize up to 600 voice frequency transmission paths. Certain frequencies within the bandwidth of the Interface Group are reserved for Telephone Company use, e.g., pilot and carrier group alarm tones. Before the first point of switching, the Telephone Company will provide multiplex and channel bank equipment to derive 600 transmission paths with a frequency bandwidth of approximately 300 to 3000 Hz.

The interface is provided with SF supervisory signaling for each individual transmission channel.

9.1.6 Interface Group 6

Interface Group 6 provides DS1 level digital transmission at the point of termination at the customer's premises. The interface is capable of transmitting electrical signals at a nominal 1.544 Mbps, with the capability to channelize up to

** New or Revised*

Continued

DATE ISSUED: July 31, 2002

EFFECTIVE DATE: September 18, 2002

Aloa J. Stevens
Director – State Government Affairs
Citizens Communications Company
4 Triad Center, Suite 200
Salt Lake City, Utah 84180

ACCESS SERVICE

9. Interface Groups, Transmission Specifications, and Channel Codes (Cont'd)

9.1 Local Transport Interface Groups (Cont'd)

9.1.6 Interface Group 6 (Cont'd)

24 voice frequency transmission paths. Before the first point of switching, when analog switching utilizing analog terminations is provided, the Telephone Company will provide multiplex and channel bank equipment to derive 24 transmission paths with a frequency bandwidth of approximately 300 to 3000 Hz. When digital switching or analog switching with digital carrier terminations is provided, the Telephone Company will provide, at the first point of switching, a DS1 signal in D3/D4 format.

The interface is provided with bit stream supervisory signaling for each individual transmission channel.

9.1.7 Interface Group 7

Interface Group 7 provides DS1C level digital transmission at the point of termination at the customer's premises. The interface is capable of transmitting electrical signals at a nominal 3.152 Mbps, with the capability to channelize up to 48 voice frequency transmission paths. Before the first point of switching, when analog switching utilizing analog terminations is provided, the Telephone Company will provide multiplex and channel bank equipment to derive up to 48 voice frequency transmission paths with a frequency bandwidth of approximately 300 to 3000 Hz. When digital switching or analog switching with digital carrier terminations is provided, the Telephone Company will provide, at the first point of switching, DS1 signals in D3/D4 format.

The interface is provided with bit stream supervisory signaling for each individual transmission channel.

** New or Revised*

Continued

DATE ISSUED: July 31, 2002

EFFECTIVE DATE: September 18, 2002

Aloa J. Stevens
Director – State Government Affairs
Citizens Communications Company
4 Triad Center, Suite 200
Salt Lake City, Utah 84180

ACCESS SERVICE

9. Interface Groups, Transmission Specifications, and Channel Codes (Cont'd)

9.1 Local Transport Interface Groups (Cont'd)

9.1.8 Interface Group 8

Interface Group 8 provides DS2 level digital transmission at the point of termination at the customer's premises. The interface is capable of transmitting electrical signals at a nominal 6.312 Mbps, with the capability to channelize up to 96 voice frequency transmission paths. Before the first point of switching, when analog switching utilizing analog terminations is provided, the Telephone Company will provide multiplex and channel bank equipment in its office to derive up to 96 transmission paths with a frequency bandwidth of approximately 300 to 3000 Hz. When digital switching, or analog switching with digital carrier terminations is provided, the Telephone Company will provide, at the first point of switching, DS1 signals in D3/D4 format.

The interface is provided with bit stream supervisory signaling for each individual transmission channel.

9.1.9 Interface Group 9

Interface Group 9 provides DS3 level digital transmission at the point of termination at the customer's premises. The interface is capable of transmitting electrical signals at a nominal 44.736 Mbps, with the capability to channelize up to 672 voice frequency transmission paths. Before the first point of switching, when analog switching utilizing analog terminations is provided, the Telephone Company will provide multiplex and channel bank equipment to derive up to 672 transmission paths with a frequency bandwidth of approximately 300 to 3000 Hz. When digital switching, or analog switching with digital carrier terminations is provided, the Telephone Company will provide, at the first point of switching, DS1 signals in D3/D4 format.

** New or Revised*

Continued

DATE ISSUED: July 31, 2002

EFFECTIVE DATE: September 18, 2002

Aloa J. Stevens
Director – State Government Affairs
Citizens Communications Company
4 Triad Center, Suite 200
Salt Lake City, Utah 84180

ACCESS SERVICE

9. Interface Groups, Transmission Specifications, and Channel Codes (Cont'd)

9.1 Local Transport Interface Groups (Cont'd)

9.1.9 Interface Group 9 (Cont'd)

The interface is provided with bit stream supervisory signaling for each individual transmission channel.

9.1.10 Interface Group 10

Interface Group 10 provides DS4 level digital transmission at the point of termination at the customer's premises. The interface is capable of transmitting electrical signals at a nominal 274.176 Mbps, with the capability to channelize up to 4032 voice frequency transmission paths. Before the first point of switching, when analog switching utilizing analog terminations is provided, the Telephone Company will provide multiplex and channel bank equipment to derive up to 4032 transmission paths with a frequency bandwidth of approximately 300 to 3000 Hz. When digital switching or analog switching with digital carrier terminations is provided, the Telephone Company will provide, at the first point of switching, DS1 signals in D3/D4 format.

The interface is provided with bit stream supervisory signaling for each individual transmission channel.

9.1.11 Available Premises Interface Codes

Following is a matrix showing which premises interface codes are available for each Interface Group as a function of the Telephone Company switch supervisory signaling and Feature Group. For explanations of these codes, see the Glossary of Channel Interface Codes in 9.3.1 following.

** New or Revised*

Continued

DATE ISSUED: July 31, 2002

EFFECTIVE DATE: September 18, 2002

Aloa J. Stevens
Director – State Government Affairs
Citizens Communications Company
4 Triad Center, Suite 200
Salt Lake City, Utah 84180

ACCESS SERVICE

9. Interface Groups, Transmission Specifications, and Channel Codes (Cont'd)9.1 Local Transport Interface Groups (Cont'd)9.1.11 Available Premises Interface Codes (Cont'd)

<u>Interface Group</u>	<u>Telephone Company Switch Supervisory Signaling</u>	<u>Premises Interface Code</u>	<u>Feature Group</u>			
			<u>A</u>	<u>B</u>	<u>C</u>	<u>D</u>
1	LO	2LS2	X			
	LO	2LS3	X			
	GO	2GS2	X			
	GO	2GS3	X			
	LO, GO	2DX3	X			
	LO, GO	4EA3-E	X			
	LO, GO	4EA3-M	X			
	LO, GO	6EB3-E	X			
	LO, GO	6EB3-M	X			
	RV, EA, EB, EC	2DX3		X	X	
	X	RV, EA, EB, EC	4EA3-E		X	X
	X	RV, EA, EB, EC	4EA3-M		X	X
	X	RV, EA, EB, EC	6EB3-E		X	X
	X	RV, EA, EB, EC	6EB3-M		X	X
X	EA, EB, EC	6EC3			X	
X	RV	2RV3-O		X	X	
X	RV	2RV3-T		X	X	
2	LO, GO	4SF2	X			
	LO, GO	4SF3	X			
	LO	4LS2	X			
	LO	4LS3	X			
	LO	6LS2	X			
	GO	4GS2	X			
	GO	4GS3	X			
	GO	6GS2	X			
	LO, GO	4DX2	X			
	LO, GO	4DX3	X			
	LO, GO	6EA2-E	X			
	LO, GO	6EA2-M	X			

* New or Revised

Continued

DATE ISSUED: July 31, 2002

EFFECTIVE DATE: September 18, 2002

Aloa J. Stevens
 Director – State Government Affairs
 Citizens Communications Company
 4 Triad Center, Suite 200
 Salt Lake City, Utah 84180

ACCESS SERVICE

9. Interface Groups, Transmission Specifications, and Channel Codes (Cont'd)9.1 Local Transport Interface Groups (Cont'd)9.1.11 Available Premises Interface Codes (Cont'd)

<u>Interface Group</u>	<u>Telephone Company Switch Supervisory Signaling</u>	<u>Premises Interface Code</u>	<u>Feature Group</u>			
			<u>A</u>	<u>B</u>	<u>C</u>	<u>D</u>
2 (Cont'd)	LO, GO	8EB2-E	X			
	LO, GO	8EB2-M	X			
	LO, GO	6EX2-B	X			
	RV, EA, EB, EC	4SF2		X		X
	RV, EA, EB, EC	4SF3		X		
	RV, EA, EB, EC	4DX2		X	X	X
	RV, EA, EB, EC	4DX3		X	X	X
	RV, EA, EB, EC	6DX2			X	
	RV, EA, EB, EC	6EA2-E		X	X	X
	RV, EA, EB, EC	6EA2-M		X	X	X
	RV, EA, EB, EC	8EB2-E		X	X	X
	RV, EA, EB, EC	8EB2-M		X	X	X
	EA, EB, EC	8EC2-M			X	X
	RV	4RV2-O		X	X	X
	RV	4RV2-T		X	X	X
	RV	4RV3-O		X	X	
	RV	4RV3-T		X	X	
	3	LO, GO	4AH5-B	X		
RV, EA, EB, EC		4AH5-B		X	X	X
4	LO, GO	4AH6-C	X			
	RV, EA, EB, EC	4AH6-C		X	X	X
5	LO, GO	4AH6-D	X			
	RV, EA, EB, EC	4AH6-D		X	X	X

* New or Revised

Continued

DATE ISSUED: July 31, 2002

EFFECTIVE DATE: September 18, 2002

Aloa J. Stevens
 Director – State Government Affairs
 Citizens Communications Company
 4 Triad Center, Suite 200
 Salt Lake City, Utah 84180

ACCESS SERVICE

9. Interface Groups, Transmission Specifications, and Channel Codes (Cont'd)9.1 Local Transport Interface Groups (Cont'd)9.1.11 Available Premises Interface Codes (Cont'd)

Interface Group	Telephone Company Switch Supervisory Signaling	Premises Interface Code	Feature Group			
			A	B	C	D
6	LO, GO	4DS9-15	X			
	LO, GO	4DS9-15L	X			
	RV, EA, EB, EC	4DS9-15		X	X	
	RV, EA, EB, EC	4DS9-15L X		X	X	X
7	LO, GO	4DS9-31	X			
	RV, EA, EB, EC	4DS9-32		X	X	
X	LO, GO	4DS9-31L	X			
X	RV, EA, EB, EC	4DS9-31L		X	X	
8	LO, GO	4DSO-63	X			
	LO, GO	4DSO-63L	X			
	RV, EA, EB, EC	4DSO-63		X	X	
X	RV, EA, EB, EC	4DSO-63L		X	X	
X						
9	LO, GO	4DS6-44	X			
	LO, GO	4DS6-44L	X			
	RV, EA, EB, EC	4DS6-44		X	X	
X	RV, EA, EB, EC	4DS6-44L		X	X	
X						
10	LO, GO	4DS6-27	X			
	LO, GO	4DS6-27L	X			
	RV, EA, EB, EC	4DS6-27		X	X	
X	RV, EA, EB, EC	4DS6-27L		X	X	
X						

* New or Revised

Continued

DATE ISSUED: July 31, 2002

EFFECTIVE DATE: September 18, 2002

Aloa J. Stevens
 Director – State Government Affairs
 Citizens Communications Company
 4 Triad Center, Suite 200
 Salt Lake City, Utah 84180

 ACCESS SERVICE

9. Interface Groups, Transmission Specifications, and Channel Codes (Cont'd)9.2 Transmission Specifications for Switched Access Service

The Telephone Company will maintain existing transmission specifications on functioning service configurations installed prior to the effective date of this tariff except that service configurations having performance specifications exceeding the standards listed in this provision will be maintained at performance levels specified in this tariff.

The transmission specifications contained in this Section are immediate action limits. Acceptance limits are set forth in Technical Reference TR-NPL-000334. This Technical Reference also provides the basis for determining Switched Access Service maintenance limits.

9.2.1 Standard Transmission Specifications

Following are descriptions of the three Standard Transmission Specifications available with Switched Access Services. The specific applications in terms of the Switched Access Arrangements and Interface Groups with which the Switched Access Arrangement Standard Transmission Specifications are provided are set forth in Section 6 preceding. (T)

(A) Type A Transmission Specifications

Type A Transmission Specifications is provided with the following parameters:

(1) Loss Deviation

The maximum Loss Deviation of the 1004 Hz loss relative to the Expected Measured Loss (EML) is ± 2.0 dB

(2) Attenuation Distortion

The maximum Attenuation Distortion in the 404 to 2804 Hz frequency band relative to the loss 1004 Hz is -1.0 dB to +3.0 dB.

Continued

DATE ISSUED: May 9, 2012

EFFECTIVE DATE: July 1, 2012

Kenneth Mason
 Vice President – Government & Regulatory Affairs
 Citizens Communications Company
 180 S. Clinton Ave.
 Rochester, NY 14646

ACCESS SERVICE

9. Interface Groups, Transmission Specifications, and Channel Codes (Cont'd)9.2 Transmission Specifications for Switched Access Service (Cont'd)9.2.1 Standard Transmission Specifications (Cont'd)(A) Type A Transmission Specifications (Cont'd)(3) C-Message Noise

The maximum C-Message Noise for the transmission path at the route miles listed is less than or equal to:

<u>Route Miles</u>	<u>C-Message Noise</u>
less than 50	32 dBrnCO
51 to 100	34 dBrnCO
101 to 200	37 dBrnCO
201 to 400	40 dBrnCO
401 to 1000	42 dBrnCO

(4) C-Notch Noise

The maximum C-Notch Noise, utilizing a -16 dBmO holding tone, is less than or equal to 45 dBrnCO.

(5) Echo Control

Echo Control, identified as Equal Level Echo Path Loss, and expressed as Echo Return Loss and Singing Return Loss, is dependent on the routing, i.e., whether the service is routed directly from the customer's point of termination (POT) to the end office or via an access tandem. It is equal to or greater than the following:

* *New or Revised**Continued*

DATE ISSUED: July 31, 2002

EFFECTIVE DATE: September 18, 2002

Aloa J. Stevens
Director – State Government Affairs
Citizens Communications Company
4 Triad Center, Suite 200
Salt Lake City, Utah 84180

ACCESS SERVICE

9. Interface Groups, Transmission Specifications, and Channel Codes (Cont'd)9.2 Transmission Specifications for Switched Access Service (Cont'd)9.2.1 Standard Transmission Specifications (Cont'd)(A) Type A Transmission Specifications (Cont'd)(5) Echo Control (Cont'd)

	<u>Echo Return Loss</u>	<u>Singing Return Loss</u>
POT to Access Tandem	21 dB	14 dB
POT to End Office - Direct	N/A	N/A
-Via Access Tandem	16 dB	11 dB

(6) Standard Return Loss

Standard Return Loss expressed as Echo Return Loss and Singing Return Loss on two-wire ports of a four-wire point of termination shall be equal to or greater than:

<u>Echo Return Loss</u>	<u>Singing Return Loss</u>
5 dB	2.5 dB

(B) Type B Transmission Specifications

Type B Transmission Specifications is provided with the following parameters:

* *New or Revised**Continued*

DATE ISSUED: July 31, 2002

EFFECTIVE DATE: September 18, 2002

Aloa J. Stevens
Director – State Government Affairs
Citizens Communications Company
4 Triad Center, Suite 200
Salt Lake City, Utah 84180

ACCESS SERVICE

9. Interface Groups, Transmission Specifications, and Channel Codes (Cont'd)9.2 Transmission Specifications for Switched Access Service (Cont'd)9.2.1 Standard Transmission Specifications (Cont'd)(B) Type B Transmission Specifications (Cont'd)(1) Loss Deviation

The maximum Loss Deviation of the 1004 Hz loss relative to the Expected Measured Loss (EML) is ± 2.5 dB.

(2) Attenuation Distortion

The maximum Attenuation Distortion is the 404 to 2804 Hz frequency band relative to loss at 1004 Hz is -2.0 dB to +4.0 dB.

(3) C-Message Noise

The maximum C-Message Noise for the transmission path at the route miles listed is less than or equal to:

<u>Route Miles</u>	<u>C-Message Noise*</u>	
	<u>Type B1</u>	<u>Type B2</u>
less than 50	32 dBrnCO	35 dBrnCO
51 to 100	33 dBrnCO	37 dBrnCO
101 to 200	35 dBrnCO	40 dBrnCO
201 to 400	37 dBrnCO	43 dBrnCO
401 to 1000	39 dBrnCO	45 dBrnCO

* For Feature Groups C and D only Type B2 will be provided. For Feature Groups A and B, Type B1 or B2 will be provided as set forth in Technical Reference TR-NPL-000334.

** New or Revised*

Continued

DATE ISSUED: July 31, 2002

EFFECTIVE DATE: September 18, 2002

Aloa J. Stevens
Director – State Government Affairs
Citizens Communications Company
4 Triad Center, Suite 200
Salt Lake City, Utah 84180

ACCESS SERVICE

9. Interface Groups, Transmission Specifications, and Channel Codes (Cont'd)9.2 Transmission Specifications for Switched Access Service (Cont'd)9.2.1 Standard Transmission Specifications (Cont'd)(B) Type B Transmission Specifications (Cont'd)(4) C-Notch Noise

The maximum C-Notch Noise, utilizing a -16 dBmO holding tone is less than or equal to 47 dBmCO.

(5) Echo Control

Echo Control, identified as Impedance Balance for FGA and FGB and Equal Level Echo Path Loss for FGC and FGD, and expressed as Echo Return Loss (ERL) and Singing Return Loss (SRL), is dependent on the routing, i.e., whether the service is routed directly from the customer's point of termination (POT) to the end office or via an access tandem. The ERL and SRL also differ by Switched Access Service, type of termination, and type of transmission path. They are greater than or equal to the following:

	<u>Echo Return Loss</u>	<u>Singing Return Loss</u>
POT to Access Tandem		
- Terminated in Four-Wire trunk	21 dB	14 dB
POT to End Office		
- Terminated in Two-Wire trunk	16 dB	11 dB

* *New or Revised**Continued*

DATE ISSUED: July 31, 2002

EFFECTIVE DATE: September 18, 2002

Aloa J. Stevens
Director – State Government Affairs
Citizens Communications Company
4 Triad Center, Suite 200
Salt Lake City, Utah 84180

ACCESS SERVICE

9. Interface Groups, Transmission Specifications, and Channel Codes (Cont'd)

9.2 Transmission Specifications for Switched Access Service (Cont'd)

9.2.1 Standard Transmission Specifications (Cont'd)

(B) Type B Transmission Specifications (Cont'd)

(5) Echo Control (Cont'd)

	<u>Echo Return Loss</u>	<u>Singing Return Loss</u>
POT to End Office		
- Direct	16 dB	11 dB
- Via Access Tandem		
. For FGB access	8 dB	4 dB
. For FGC access (Effective Four-Wire trans- mission path at end office)	16 dB	11 dB
. For FGC access (Effective Two-Wire trans- mission path at end office)	13 dB	6 dB

(6) Standard Return Loss

Standard Return Loss, expressed as Echo Return Loss and Singing Return Loss, on two-wire ports of a four-wire point of termination shall be equal to or greater than:

<u>Echo Return Loss</u>	<u>Singing Return Loss</u>
5 dB	2.5 dB

** New or Revised*

Continued

DATE ISSUED: July 31, 2002

EFFECTIVE DATE: September 18, 2002

Aloa J. Stevens
Director – State Government Affairs
Citizens Communications Company
4 Triad Center, Suite 200
Salt Lake City, Utah 84180

ACCESS SERVICE

9. Interface Groups, Transmission Specifications, and Channel Codes (Cont'd)9.2 Transmission Specifications for Switched Access Service (Cont'd)9.2.1 Standard Transmission Specifications (Cont'd)(C) Type C Transmission Specifications

Type C Transmission Specifications is provided with the following parameters:

(1) Loss Deviation

The maximum Loss Deviation of the 1004 Hz loss relative to the Expected Measured Loss (EML) is ± 3.0 dB.

(2) Attenuation Distortion

The maximum Attenuation Distortion in the 404 to 2804 Hz frequency band relative to loss at 1004 Hz is -2.0 dB to +5.5 dB.

(3) C-Message Noise

The maximum C-Message Noise for the transmission path at the route miles listed is less than or equal to:

<u>Route Miles</u>	<u>C-Message Noise*</u>	
	<u>Type B1</u>	<u>Type B2</u>
less than 50	32 dBrnCO	38 dBrnCO
51 to 100	33 dBrnCO	39 dBrnCO
101 to 200	35 dBrnCO	41 dBrnCO
201 to 400	37 dBrnCO	43 dBrnCO
401 to 1000	39 dBrnCO	45 dBrnCO

* For Feature Groups C and D only Type C2 will be provided. For Feature Groups A and B, Type C1 or C2 will be provided set forth in Technical Reference TR-NPL-000334.

ACCESS SERVICE

9. Interface Groups, Transmission Specifications, and Channel Codes (Cont'd)9.2 Transmission Specifications for Switched Access Service (Cont'd)9.2.1 Standard Transmission Specifications (Cont'd)(C) Type C Transmission Specifications (Cont'd)(4) C-Notch Noise

The maximum C-Notch Noise, utilizing a -16 dBmO holding tone is less than or equal to 47 dBmCO.

(5) Echo Control

Echo Control, identified as Return Loss and expressed as Echo Return Loss and Singing Return Loss is dependent on the routing, i.e., whether the service is routed directly from the customer's point of termination (POT) to the end office or via an access tandem. It is equal to or greater than the following:

	<u>Echo Return Loss</u>	<u>Singing Return Loss</u>
POT to Access Tandem	13 dB	6 dB
POT to End Office		
- Direct	13 dB	6 dB
- Via Access Tandem (for FGB only)	8 dB	4 dB

* *New or Revised**Continued*

DATE ISSUED: July 31, 2002

EFFECTIVE DATE: September 18, 2002

Aloa J. Stevens
Director – State Government Affairs
Citizens Communications Company
4 Triad Center, Suite 200
Salt Lake City, Utah 84180

 ACCESS SERVICE

9. Interface Groups, Transmission Specifications, and Channel Codes (Cont'd)9.2 Transmission Specifications for Switched Access Service (Cont'd)9.2.2 Data Transmission Parameters

Two types of Data Transmission Parameters, i.e., Type DA and Type DB, are provided for the Switched Access Service arrangements. The specific applications in terms of the Feature Groups with which they are provided are set forth in Section 6 preceding. In addition, the Combined Access Service Arrangement is provided with Data Transmission Parameters. Following are descriptions of each parameter. (T)

(A) Data Transmission Parameters Type DA(1) Signal to C-Notched Noise Ratio

The Signal to C-Notched Noise Ratio is equal to or greater than 33 dB.

(2) Envelope Delay Distortion

The maximum envelope Delay Distortion for the frequency bands and route miles specified is:

604 to 2804 Hz

Less than 30 route miles: 500 microseconds

Equal to or greater than

30 route miles: 900 microseconds

1004 to 2404 Hz

Less than 50 route miles: 200 microseconds

Equal to or greater than

50 route miles: 400 microseconds

Continued

DATE ISSUED: May 9, 2012

EFFECTIVE DATE: July 1, 2012

Kenneth Mason
 Vice President – Government & Regulatory Affairs
 Citizens Communications Company
 180 S. Clinton Ave.
 Rochester, NY 14646

ACCESS SERVICE

9. Interface Groups, Transmission Specifications, and Channel Codes (Cont'd)

9.2 Transmission Specifications for Switched Access Service (Cont'd)

9.2.2 Data Transmission Parameters (Cont'd)

(A) Data Transmission Parameters Type DA (Cont'd)

(3) Impulse Noise Counts

The Impulse Noise Counts exceeding a 65 dBmCO threshold in 15 minutes is no more than 15 counts.

(4) Intermodulation Distortion

The Second Order (R2) and Third Order (R3) Intermodulation Distortion products are equal to or greater than:

Second Order (R2)	33 dB
Third Order (R3)	37 dB

(5) Phase Jitter

The Phase Jitter over the 4-300 Hz frequency band is less than or equal to 5° peak-to-peak.

(6) Frequency Shift

The maximum Frequency Shift does not exceed -2 to +2 Hz.

(B) Data Transmission Parameters Type DB

(1) Signal to C-Notched Noise Ratio

The signal to C-Notched Noise Ratio is equal to or greater than 30 dB.

** New or Revised*

Continued

DATE ISSUED: July 31, 2002

EFFECTIVE DATE: September 18, 2002

Aloa J. Stevens
Director – State Government Affairs
Citizens Communications Company
4 Triad Center, Suite 200
Salt Lake City, Utah 84180

ACCESS SERVICE

9. Interface Groups, Transmission Specifications, and Channel Codes (Cont'd)9.2 Transmission Specifications for Switched Access Service (Cont'd)9.2.2 Data Transmission Parameters (Cont'd)(B) Data Transmission Parameters Type DB (Cont'd)(2) Envelope Delay Distortion

The maximum Envelope Delay Distortion for the frequency bands and route miles specified is:

604 to 2804 Hz

Less than 50 route miles: 800 microseconds

Equal to or greater than

50 route miles: 1000 microseconds

1004 to 2404 Hz

Less than 50 route miles: 320 microseconds

Equal to or greater than

50 route miles: 500 microseconds

(3) Impulse Noise Counts

The Impulse Noise Counts exceeding a 67 dB_{rnCO} threshold in 15 minutes is no more than 15 counts.

(4) Intermodulation Distortion

The Second Order (R2) and Third Order (R3) Intermodulation Distortion products are equal to or greater than:

Second Order (R2)	31 dB
Third Order (R3)	34 dB

* *New or Revised**Continued*

DATE ISSUED: July 31, 2002

EFFECTIVE DATE: September 18, 2002

Aloa J. Stevens
Director – State Government Affairs
Citizens Communications Company
4 Triad Center, Suite 200
Salt Lake City, Utah 84180

ACCESS SERVICE

9. Interface Groups, Transmission Specifications, and Channel Codes (Cont'd)9.2 Transmission Specifications for Switched Access Service (Cont'd)9.2.2 Data Transmission Parameters (Cont'd)(B) Data Transmission Parameters Type DB (Cont'd)(5) Phase Jitter

The Phase Jitter over the 4-300 Hz frequency band is less than or equal to 7° peak-to-peak.

(6) Frequency Shift

The maximum frequency Shift does not exceed -2 to +2 Hz.

9.3 Channel Interface and Network Channel Codes

This section explains the Channel Interface codes and Network Channel codes that the customer must specify when ordering Special Access Service. Included is an example which explains the specific characters of the code, a glossary of Channel Interface codes, impedance levels, Network Channel codes and compatible Channel Interfaces.

Example: If the customer specifies a NT Network Channel Code and a 2DS8-3 Channel Interface at the customer's premises, the following is being requested:

- NT = Metallic Circuit with a Predefined Technical Specification Package (1)
- 2 = Number of physical wires at customer premises
- D.C. = Facility interface for direct current or voltage
- 8 = Variable impedance level
- 3 = Metallic facilities (D.C. continuity) for direct current/low frequency control signals or slow speed data (30 baud)

* *New or Revised**Continued*

DATE ISSUED: July 31, 2002

EFFECTIVE DATE: September 18, 2002

Aloa J. Stevens
Director – State Government Affairs
Citizens Communications Company
4 Triad Center, Suite 200
Salt Lake City, Utah 84180

ACCESS SERVICE

9. Interface Groups, Transmission Specifications, and Channel Codes (Cont'd)9.3 Channel Interface and Network Channel Codes (Cont'd)9.3.1 Glossary of Channel Interface Codes and Options

<u>Code</u>	<u>Option</u>	<u>Definition</u>
AB	-	Accepts 20 Hz ringing signal at customer's point of termination
AC	-	Accepts 20 Hz ringing signal at customer's end user's point of termination
AH	-	Analog high capacity interface
	B	60 kHz to 108 kHz (12 channels)
	C	312 kHz to 552 kHz (60 channels)
	D	564 kHz to 3084 kHz (600 channels)
CT	-	Centrex Tie Trunk Termination
DA	-	Data stream in VF frequency band at customer's end user's point of termination
DB	-	Data stream in VF frequency band at customer's point of termination
	10	VF for TG1 and TG2
	43	VF for 43 Telegraph Carrier type signals, TG1 and TG2 D.C. -direct current or voltage
	1	Monitoring interface with series RC combination (McCulloh format)
	2	Telephone Company energized alarm channel
	3	Metallic facilities (D.C. continuity) for direct current/low frequency control signals or slow speed data (30 baud)

* New or Revised

Continued

DATE ISSUED: July 31, 2002

EFFECTIVE DATE: September 18, 2002

Aloa J. Stevens
 Director – State Government Affairs
 Citizens Communications Company
 4 Triad Center, Suite 200
 Salt Lake City, Utah 84180

ACCESS SERVICE

9. Interface Groups, Transmission Specifications, and Channel Codes (Cont'd)9.3 Channel Interface and Network Channel Codes (Cont'd)9.3.1 Glossary of Channel Interface Codes and Options (Cont'd)

<u>Code</u>	<u>Option</u>	<u>Definition</u>
DD	-	DATAPHONE Select-A-Station (and TABS) interface at customer's point of termination
DE	-	DATAPHONE Select-A-Station (and TABS) interface at the customer's end user's point of termination
DS	-	Digital hierarchy interface
	15	1.544 Mbps (DS1) format per PUB 41451 plus D4
	15E	8-bit PCM encoded in one 64 kbps of the DS1 signal
	15F	8-bit PCM encoded in two 64 kbps of the DS1 signal
	15G	8-bit PCM encoded in three 64 kbps of the DS1 signal
	15H	14/11-bit PCM encoded in six 64 kbps of the DS1 signal
	15J	1.544 Mbps format per PUB 41451
	15K	1.544 Mbps format per PUB 41451 plus extended framing format
	15L	1.544 Mbps (DS1) with SF signaling
	27	274.176 Mbps (DS4)
	27L	274.176 Mbps (DS4) with SF signaling
	31	3.152 Mbps (DS1C)
	31L	3.152 Mbps (DS1C) with SF signaling
	44	44.736 Mbps (DS3)
	44L	44.736 Mbps (DS3) with SF signaling
	63	6.312 Mbps (DS2)
	63L	6.312 Mbps (DS2) with SF signaling

* New or Revised

Continued

DATE ISSUED: July 31, 2002

EFFECTIVE DATE: September 18, 2002

Aloa J. Stevens
 Director – State Government Affairs
 Citizens Communications Company
 4 Triad Center, Suite 200
 Salt Lake City, Utah 84180

ACCESS SERVICE

9. Interface Groups, Transmission Specifications, and Channel Codes (Cont'd)9.3 Channel Interface and Network Channel Codes (Cont'd)9.3.1 Glossary of Channel Interface Codes and Options (Cont'd)

<u>Code</u>	<u>Option</u>	<u>Definition</u>
DU -		Digital access interface
-	24	2.4 kbps
-	48	4.8 kbps
-	56	56.0 kbps
-	96	9.6 kbps
-	A	1.544 Mbps format per PUB 41451
-	B	1.544 Mbps format per PUB 41451 plus D4
-	C	1.544 Mbps format per PUB 41451 plus extended framing format
DX -		Duplex signaling interface at customer's point of termination
DY -		Duplex signaling interface at customer's end user's point of termination
EA -	E	Type I E&M Lead Signaling. Customer at POT or customer's end user at POT originates on E Lead.
EA -	M	Type I E&M Lead Signaling. Customer at POT or customer's end user at POT originates on M Lead.
EB -	E	Type II E&M Lead Signaling. Customer at POT or customer's end user at POT originates on E Lead.

* New or Revised

Continued

DATE ISSUED: July 31, 2002

EFFECTIVE DATE: September 18, 2002

Aloa J. Stevens
 Director – State Government Affairs
 Citizens Communications Company
 4 Triad Center, Suite 200
 Salt Lake City, Utah 84180

ACCESS SERVICE

9. Interface Groups, Transmission Specifications, and Channel Codes (Cont'd)9.3 Channel Interface and Network Channel Codes (Cont'd)9.3.1 Glossary of Channel Interface Codes and Options (Cont'd)

<u>Code</u>	<u>Option</u>	<u>Definition</u>
EB -	M	Type II E&M Lead Signaling. Customer at POT or customer's end user at POT originates on M Lead.
EC -		Type III E&M signaling at customer POT
EX -	A	Tandem channel unit signaling for loop start or ground start and customer supplies open end (dial tone, etc.) functions.
EX -	B	Tandem channel unit signaling for loop start or ground start and customer supplies closed end (dial pulsing, etc.) functions.
GO -		Ground start loop signaling - open end function by customer or customer's end user.
GS -		Ground start loop signaling - closed end function by customer or customer's end user
IA -		E.I.A. (25 pin RS-232)
LA -		End user loop start loop signaling - Type A OPS registered port open end

* *New or Revised**Continued*

DATE ISSUED: July 31, 2002

EFFECTIVE DATE: September 18, 2002

Aloa J. Stevens
 Director – State Government Affairs
 Citizens Communications Company
 4 Triad Center, Suite 200
 Salt Lake City, Utah 84180

ACCESS SERVICE

9. Interface Groups, Transmission Specifications, and Channel Codes (Cont'd)9.3 Channel Interface and Network Channel Codes (Cont'd)9.3.1 Glossary of Channel Interface Codes and Options (Cont'd)

<u>Code</u>	<u>Option</u>	<u>Definition</u>
LB	-	End user loop start loop signaling - Type B OPS registered port open end
LC	-	End user loop start loop signaling - Type C OPS registered port open end
LO	-	Loop start loop signaling - open end function by customer or customer's end user
LR	-	20 Hz automatic ringdown interface at customer with Telephone Company provided PLAR
LS	-	Loop start loop signaling - closed end function by customer or customer's end user
NO	-	No signaling interface, transmission only
PG	-	Program transmission - no d.c. signaling
	1	Nominal frequency from 50 to 15000 Hz
	3	Nominal frequency from 200 to 3500 Hz
	5	Nominal frequency from 100 to 5000 Hz
	8	Nominal frequency from 50 to 8000 Hz

* *New or Revised**Continued*

DATE ISSUED: July 31, 2002

EFFECTIVE DATE: September 18, 2002

Aloa J. Stevens
 Director – State Government Affairs
 Citizens Communications Company
 4 Triad Center, Suite 200
 Salt Lake City, Utah 84180

ACCESS SERVICE

9. Interface Groups, Transmission Specifications, and Channel Codes (Cont'd)9.3 Channel Interface and Network Channel Codes (Cont'd)9.3.1 Glossary of Channel Interface Codes and Options (Cont'd)

<u>Code</u>	<u>Option</u>	<u>Definition</u>
PR	-	Protective relaying*
RV	-O	Reverse battery signaling, one way operation, originate by customer
	-T	Reverse battery signaling, one way operation, terminate function by customer or customer's end user
SF	-	Single frequency signaling with VF band at either customer POT or customer's end user POT
TF	-	Telephotograph interface
TT	-	Telegraph/teletypewriter interface at either customer POT or customer's end user POT
	-2	20.0 milliamperes
	-3	3.0 milliamperes
	-6	62.5 milliamperes
TV	-	Television interface
	-1	Combined (diplexed) video and one audio signal
	-2	Combined (diplexed) video and two audio signals
	-5	Video plus one (or two) audio 5 kHz signal(s) or one (or two) two wire
	-15	Video plus one (or two) audio 15 kHz signal(s)

* Available only for the transmission of audio tone protective relaying signals used in the protection of electric power systems during fault conditions.

** New or Revised*

Continued

DATE ISSUED: July 31, 2002

EFFECTIVE DATE: September 18, 2002

Aloa J. Stevens
Director – State Government Affairs
Citizens Communications Company
4 Triad Center, Suite 200
Salt Lake City, Utah 84180

ACCESS SERVICE

9. Interface Groups, Transmission Specifications, and Channel Codes (Cont'd)9.3 Channel Interface and Network Channel Codes (Cont'd)9.3.1 Glossary of Channel Interface Codes and Options (Cont'd)

<u>Code</u>	<u>Option</u>	<u>Definition</u>
WA -		Wideband bandwidth interface at customer's end user
POT -		
-	1	Limited bandwidth
-	2	Nominal passband from 29000 to 44000 Hz
WB -		Wideband data interface at customer POT
-	18S	18.75 kbps, synchronous
-	19A	Up to 19.2 kbps asynchronous
-	19S	19.2 kbps synchronous
-	23A	Up to 230.4 kbps, asynchronous
-	23S	230.4 kbps, synchronous
-	40S	40.8 kbps, synchronous
-	50A	Up to 50.0 kbps, asynchronous
-	50S	50.0 kbps synchronous
WC -		Wideband data interface at customer's end user
-	18	POT 18.75 kbps, synchronous
-	19	For 12-wire interface: 19.2 kbps, synchronous for 10-wire interface: up to 19.2 kbps,
-	23	Asynchronous up to 230.4 kbps, asynchronous
-	23S	230.4 kbps, synchronous
-	40	40.8 kbps, synchronous
-	50	For 12-wire interface: 50.0 kbps, synchronous for 10-wire interface: up to 50.0 kbps, asynchronous

* New or Revised

Continued

DATE ISSUED: July 31, 2002

EFFECTIVE DATE: September 18, 2002

Aloa J. Stevens
 Director – State Government Affairs
 Citizens Communications Company
 4 Triad Center, Suite 200
 Salt Lake City, Utah 84180

ACCESS SERVICE

9. Interface Groups, Transmission Specifications, and Channel Codes (Cont'd)9.3 Channel Interface and Network Channel Codes (Cont'd)9.3.1 Glossary of Channel Interface Codes and Options (Cont'd)

<u>Code</u>	<u>Option</u>	<u>Definition</u>
WD -		Wideband bandwidth interface at customer POT
-	1	Nominal passband from 300 to 18000 Hz
-	2	Nominal passband from 28000 to 44000 Hz
-	3	Nominal passband from 29000 to 44000 Hz

9.3.2 Impedance

The nominal reference impedance with which the channel will be terminated for the purpose of evaluating transmission performance:

<u>Value (ohms)</u>	<u>Code(s)</u>
110	0
150	1
600	2
900	3+
135	5
75	6
124	7
Variable	8
100	9

- + For those interface codes with a four-wire transmission path at the customer's POT, rather than a standard 900 ohm impedance the code (3) denotes a customer provided transmission equipment termination. Such terminations were provided to customers in accordance with the F.C.C. Docket No. 20099 Settlement Agreement.

* *New or Revised**Continued*

DATE ISSUED: July 31, 2002

EFFECTIVE DATE: September 18, 2002

Aloa J. Stevens
Director – State Government Affairs
Citizens Communications Company
4 Triad Center, Suite 200
Salt Lake City, Utah 84180

ACCESS SERVICE

9. Interface Groups, Transmission Specifications, and Channel Codes (Cont'd)9.3 Channel Interface and Network Channel Codes (Cont'd)9.3.3 Digital Hierarchy Channel Interface Codes (4DS)

Customers selecting the multiplexed four-wire DSX-1 or higher facility interface option at the customer designated premises will be requested to provide subsequent system and channel assignment data. The various digital bit rates in the digital hierarchy employ the channel interface code 4DS8, 4DS9, 4DS0 or 4DS6 plus the speed options indicated below:

<u>Interface Code and Speed Option</u>	<u>Nominal Bit Rate (Mbps)</u>	<u>Digital Hierarchy Level</u>
4DS8-15	1.544	DS1
4DS9-31	3.152	DS1C
4DS0-63	6.312	DS2
4DS6-44	44.736	DS3
4DS6-27	274.176	DS4

9.3.4 Service Designator/Network Channel Code Conversion Table

The purpose of this table is to show the relationship between the service designator codes (e.g. VGC, MT2, etc.) and the network channel codes that are used for various administrative purposes.

<u>Service Designator Code</u>	<u>Network Channel Code</u>
MTC	MQ
MT1	NT
MT2	NU
MT3	NV
TGC	NQ
TG1	NW

* *New or Revised**Continued*

DATE ISSUED: July 31, 2002

EFFECTIVE DATE: September 18, 2002

Aloa J. Stevens
Director – State Government Affairs
Citizens Communications Company
4 Triad Center, Suite 200
Salt Lake City, Utah 84180

ACCESS SERVICE

9. Interface Groups, Transmission Specifications, and Channel Codes (Cont'd)9.3 Channel Interface and Network Channel Codes (Cont'd)9.3.4 Service Designator/Network Channel Code Conversion Table (Cont'd)

<u>Service Designator Code</u>	<u>Network Channel Code</u>
TG2	NY
VGC	LQ
VG1	LB
VG2	LC
VG3	LD
VG4	LE
VG5	LF
VG6	LG
VG7	LH
VG8	LJ
VG9	LK
VG1	LN
VG1	LP
VG12	LR
APC	PQ
AP1	PE
AP2	PF
AP3	PJ
AP4	PK
TVC	TQ
TV1	TV
TV2	TW
WA1	WJ
WA1T	WQ
WA2	WL
WA2A	WR
WA3	WN
WA4	WP

* *New or Revised**Continued*

DATE ISSUED: July 31, 2002

EFFECTIVE DATE: September 18, 2002

Aloa J. Stevens
Director – State Government Affairs
Citizens Communications Company
4 Triad Center, Suite 200
Salt Lake City, Utah 84180

ACCESS SERVICE

9. Interface Groups, Transmission Specifications, and Channel Codes (Cont'd)9.3 Channel Interface and Network Channel Codes (Cont'd)9.3.4 Service Designator/Network Channel Code Conversion Table (Cont'd)

<u>Service Designator Code</u>	<u>Network Channel Code</u>
WD1	WB
WD2	WE
WD3	WF
DA1	XA
DA2	XB
DA3	XG
DA4	XH
HCO	HS
HC1	HC
HC1C	HD
HC2	HE
HC3	HF
HC4	HG

* *New or Revised**Continued*

DATE ISSUED: July 31, 2002

EFFECTIVE DATE: September 18, 2002

Aloa J. Stevens
Director – State Government Affairs
Citizens Communications Company
4 Triad Center, Suite 200
Salt Lake City, Utah 84180

ACCESS SERVICE9. Interface Groups, Transmission Specifications, and Channel Codes (Cont'd)9.3 Channel Interface and Network Channel Codes (Cont'd)9.3.5 Compatible Channel Interfaces

The following tables show the channel interface codes (CIs)
Which are compatible:

(A) Metallic

<u>Compatible CIs</u>		<u>Compatible CIs</u>	
4AH5-B	2DC8-1	4AH6-D	2DC8-2
4AH5-B	24C8-2	2DC8-1	2DC8-2
4AH6-C	2DC8-1	2DC8-3	2DC8-3
4AH6-C	2DC8-2	4DS9-*	2DC8-1
4AH6-D	2DC8-1	4DS9-*	2DC8-2

(B) Telegraph Grade

<u>Compatible CIs</u>		<u>Compatible CIs</u>		<u>Compatible CIs</u>	
4AH5-B	10IA8	4AH6-D	4TT2-6	4DB2-43+	4TT2-2
4AH5-B	2TT2-2	2DB2-10	10IA8	4DS9-*	10IA8
4AH5-B	4TT2-2	2DB2-10	2TT2-2	4DS9-*	2TT2-2
4AH5-B	2TT2-6	2DB2-10	4TT2-2	4DS9-*	4TT2-2
4AH5-B	4TT2-6	2DB2-43+	10IA8	4DS9-*	2TT2-6
4AH6-C	10IA8	2DB2-43+	2TT2-2	4DS9-*	4TT2-6
4AH6-C	2TT2-2	2DB2-43+	2TT2-6	2TT2-2	2TT2-2
4AH6-C	4TT2-2	2DB2-43+	4TT2-2	2TT2-3	2TT2-2
4AH6-C	2TT2-6	4DB2-10	10IA8	2TT2-3	4TT2-2
4AH6-C	4TT2-6	4DB2-10	2TT2-2	2TT2-6	2TT2-6
4AH6-D	10IA8	4DB2-10	4TT2-2	2TT2-6	4TT2-2
4AH6-D	2TT2-2	4DB2-43+	10IA8	4TT2-2	4TT2-2
4AH6-D	4TT2-2	4DB2-43+	2TT2-6	4TT2-6	2TT2-6
4AH6-D	2TT2-6				

* See Section 7.5.3 preceding for explanation.

+ Supplemental Channel Assignment information required.

* *New or Revised*

Continued

DATE ISSUED: July 31, 2002

EFFECTIVE DATE: September 18, 2002

Aloa J. Stevens
Director – State Government Affairs
Citizens Communications Company
4 Triad Center, Suite 200
Salt Lake City, Utah 84180

ACCESS SERVICE

9. Interface Groups, Transmission Specifications, and Channel Codes (Cont'd)9.3 Channel Interface and Network Channel Codes (Cont'd)9.3.5 Compatible Channel Interfaces (Cont'd)(C) Voice Grade

<u>Compatible CIs</u>		<u>Compatible CIs</u>		<u>Compatible CIs</u>	
4AB2	4AB2				
4AB2	4AC2	4AH5-B	6DA2	4AH6-	D2DY2
4AB3	4AC2	4AH5-B	4DA2	4AH6-C	9DY2
4AB2	2AC2	4AH5-B	2DA2	4AHG-C	9DY3
4AB3	2AC2			4AH6-C	6DY2
2AB2	2AC2	4AH6-D	4DE2	4AH6-C	6DY3
2AB3	2AC2	4AH6-C	4DE2	4AH6-C	4DY2
		4AH5-B	4DE2	4AH6-C	2DY2
4AB2	4SF2	4AH6-D	2DE2	4AH5-B	9DY2
4AB3	4SF2	4AH6-C	2DE2	4AH5-B	9DY3
		4AH5-B	2DE2	4AH5-B	6DY2
4AH6-D	4AC2			4AH5-B	6DY3
4AH6-D	2AC2	4AH6-D	4DX3	4AH5-B	4DY2
4AH6-C	4AC2	4AH6-C	4DX3	4AH5-B	2DY2
4AH6-C	2AC2	4AH5-B	4DX3		
4AH5-B	4AC2	4AH6-D	4DX2	4AH6-D	9EA2
4AH5-B	2AC2	4AH6-C	4DX2	4AH6-D	9EA3
		4AH5-B	4DX2	4AH6-D	6EA2-E
4AH6-D	2CT3			4AH6-D	6EA2-M
				4AH6-D	4EA2-E
4AH6-C	2CT3			4AH6-D	4EA2-M
4AH5-B	2CT3			4AH6-C	9EA2
4AH6-D	6DA2			4AJ7-C	9EA3
4AH6-D	4DA2	4AH6-D	9DY2	4AH6-C	6EA2-E
4AH6-D	2DA2	4AH6-D	9DY3		
4AH6-C	6DA2	4AH6-D	6DY2		
4AH6-C	4DA2	4AH6-D	6DY3		
4AH6-C	2DA2	4AH6-D	4DY2		

* New or Revised

Continued

DATE ISSUED: July 31, 2002

EFFECTIVE DATE: September 18, 2002

Aloa J. Stevens
 Director – State Government Affairs
 Citizens Communications Company
 4 Triad Center, Suite 200
 Salt Lake City, Utah 84180

ACCESS SERVICE

9. Interface Groups, Transmission Specifications, and Channel Codes (Cont'd)9.3 Channel Interface and Network Channel Codes (Cont'd)9.3.5 Compatible Channel Interfaces (Cont'd)(C) Voice Grade (Cont'd)

<u>Compatible CIs</u>		<u>Compatible CIs</u>		<u>Compatible CIs</u>	
4AH6-C	6EA2-M	4AH6-D	6GS2	4AH6-D	2LO2
4AH6-C	4EA2-E	4AH6-D	4GS2	4AH6-C	2LO3
4AH6-C	4EA2-M	4AH6-D	2GS3	4AH6-C	2LO2
4AH5-B	9EA2	4AH6-D	2GS2	4AH5-B	2LO3
4AH5-B	9EA3	4AH6-C	6GS2	4AH5-B	2LO2
4AH5-B	6EA2-E	4AH6-C	4GS2		
4AH5-B	6EA2-M	4AH6-C	2GS3	4AH6-B	4LR2
4AH5-B	4EA2-E	4AH6-C	2GS2	4AH6-D	2LR2
4AH5-B	4EA2-M	4AH5-B	6GS2	4AH6-C	4LR2
		4AH5-B	4GS2	4AH6-C	2LR2
4AH6-D	8EB2-E	4AH5-B	2GS3	4AH5-B	4LR2
4AH6-D	8EB2-M	4AH5-B	2GS2	4AH5-B	2LR2
4AH6-D	6EB2-E				
4AH6-D	6EB2-M	4AH6-D	2LA2	4AH6-D	6LS2
4AH6-C	8EB2-E	4AH6-C	2LA2	4AH6-D	4LS2
4AH6-C	8EB2-M	4AH5-B	2LA2	4AH6-D	2LS2
4AH6-C	6EB2-E			4AH6-D	2LS3
4AH6-C	6EB2-M	4AH6-D	2LB2	4AH6-C	6LS2
4AH5-B	8EB2-E	4AHG-C	2LB2	4AH6-C	4LS2
4AH5-B	8EB2-M	4AH5-B	2LB2	4AH6-C	2LS2
4AH5-B	6EB2-E			4AH6-C	2LS3
4AH5-B	6EB2-M	4AH6-D	2LC2	4AH5-B	6LS2
		4AH6-C	2LC2	4AH5-B	4LS2
4AH6-D	2GO24	AH5-B	2LC2	4AH5-B	2LS2
4AH6-D	2GO3				
4AH6-C	2GO2				
4AH6-C	2GO2			4AH5-B	2LS3
4AH5-B	2GO24	AH6-D	2LO3		
4AH5-B	2GO3				

* New or Revised

Continued

DATE ISSUED: July 31, 2002

EFFECTIVE DATE: September 18, 2002

Aloa J. Stevens
 Director – State Government Affairs
 Citizens Communications Company
 4 Triad Center, Suite 200
 Salt Lake City, Utah 84180

ACCESS SERVICE

9. Interface Groups, Transmission Specifications, and Channel Codes (Cont'd)9.3 Channel Interface and Network Channel Codes (Cont'd)9.3.5 Compatible Channel Interfaces (Cont'd)(C) Voice Grade (Cont'd)

<u>Compatible CIs</u>		<u>Compatible CIs</u>		<u>Compatible CIs</u>	
4AH6-D	4NO2	4AH6-D	4TF2	2CT3	8EB2-E
4AH6-D	2NO2	4AH7-D	2TF2	2CT3	8EB2-M
4AH6-C	4NO2	4AH6-C	4TF2		
4AH6-C	2NO2	4AH6-C	2TF2	2CT3	6EB2-E
4AH5-B	4NO2	4AH5-B	4TF2	2CT3	6EB2-M
4AH5-B	2NO2	4AH5-B	2TF2		
		2CT3	4DS9-*	2CT3	6EB3-E
				2CT3	8EC2
		2CT3	6DX2		
		2CT3	4DX2	2CT3	4SF2
		2CTS	4DX3	2CT3	4SF3
4AH6-D	4PR2	2CT3	9DY3	6DA2	6DA2
4AH6-D	2PR2	2CT3	6DY3	6DA2	4DA2
4AH6-C	4PR2	2CT3	9DT2	4DA2	4DA2
4AH6-C	2PR2	2CT3	6DY2		
4AH5-B	4PR2	2CT3	4DY3	4DB2	6DA2
4AH5-B	2PR2	2CT3	2DY2	4DB2	4DA2
				4DB2	2DA2
4AH6-D	4RV2-T	2CT3	9EA3	2DB3	2DA2
4AH6-D	2RV2-T	2CT3	9EA2	2DB2	2DA2
4AH6-C	4RV2-T	2CT3	6EA2-E	4DB2	4DB2
4AH6-C	2RV2-T	2CT3	6EA2-M	4DB2	4NO2
4AH5-B	4TV2-T	2CT3	4EA2-E	4DB2	2NO2
4AH5-B	2RV2-T	2CT3	4EA2-M	2DB2	2NO2

* See 9.3.3 preceding for explanation.

* *New or Revised**Continued*

DATE ISSUED: July 31, 2002

EFFECTIVE DATE: September 18, 2002

Aloa J. Stevens
 Director – State Government Affairs
 Citizens Communications Company
 4 Triad Center, Suite 200
 Salt Lake City, Utah 84180

ACCESS SERVICE

9. Interface Groups, Transmission Specifications, and Channel Codes (Cont'd)9.3 Channel Interface and Network Channel Codes (Cont'd)9.3.5 Compatible Channel Interfaces (Cont'd)(C) Voice Grade (Cont'd)

<u>Compatible CIs</u>		<u>Compatible CIs</u>		<u>Compatible CIs</u>	
4AH6-D	4SF2			4DB2	4PR2
4AH6-C	4SF2			4DB2	2PR2
4AH5-B	4SF2			2DB2	2PR2
4AH6-D	4SF3				
4AH6-C	4SF3				
4AH5-B	4SF3				
4DD3	4DE2	4DS8-*	9DY3		
4DD3	2DE2	4DS8-*	9DY2		
		4DS8-*	6DY3		
4DS8-*	4AC2	4DS8-*	6DY2		
4DS8-*	2AC2	4DS8-*	4DY2		
		4DS8-*	2DY2		
4DS8-*	6DA2				
4DS8-*	4DA2				
4DS8-*	2DA2	4DS8-*	9EA2		
		4DS8-*	9EA3		
4DS8-*	4DE2	4DS8-*	6EA2-E		
4DS8-*	EDE2	4DS8-*	6EA2-M		
		4DS8-*	4EA2-E		
4DS8-*	4DX3	4DS8-*	4EA2-E		
4DS8-*	4DX2				

* See 9.3.3 preceding for explanation.

* *New or Revised**Continued*

DATE ISSUED: July 31, 2002

EFFECTIVE DATE: September 18, 2002

Aloa J. Stevens
 Director – State Government Affairs
 Citizens Communications Company
 4 Triad Center, Suite 200
 Salt Lake City, Utah 84180

ACCESS SERVICE

9. Interface Groups, Transmission Specifications, and Channel Codes (Cont'd)9.3 Channel Interface and Network Channel Codes (Cont'd)9.3.5 Compatible Channel Interfaces (Cont'd)(C) Voice Grade (Cont'd)

<u>Compatible CIs</u>		<u>Compatible CIs</u>		<u>Compatible CIs</u>	
4DS8-*	8EB2-E	4DS8-*	4NO2	4DX3	9DY2
4DS8-*	8EB2-M	4DS8-*	2NO2	4DX2	6DY3
4DS8-*	6EB2-E			4DX3	6DY3
4DS8-*	6EB2-M	4DS8-*	4PR2	4DX2	6DY2
		4DS8-*	2PR2	4DX3	6DY2
4DS8-*	2GO2			4DX2	4DY2
4DS8-*	2GO3	4DS8-*	4RV2-T	4DX3	4DY2
4DS8-*	6GS2	4DS8-*	2RV2-T	4DX2	2DY2
4DS8-*	4GS2			4DX3	2DY2
4DS8-*	2GS2	4DS8-*	4SF2		
4DS8-*	2GS3	4DS8-*	4SF3	6DX2	9EA3
				6DX2	9EA2
4DS8-*	2LA2	4DS8-*	4TF2	6DX2	6EA2-E
		4DS8-*	2TF2	6DX2	6EA2-M
4DS8-*	2LB2			6DX2	4EA2-E
		4DX2	4DX2	6DX2	4EA2-M
8DS8-*	2LC2	4DX3	4DX2	4DX2	9EA2
		4DX3	4DX3	4DX3	9EA2
4DS8-*	2LO2		4DX2	9EA3	
4DS8-*	2LO3	6DX2	9DY3	4DX3	9EA3
		6DX2	9DY2	4DX2	6EA2-E
4DS8-*	4LR2	6DX2	6DY3	4DX3	6EA2-E
4DS8-*	2LR2	6DX2	6DY2	4DX2	6EA2-M
		6DX2	4DY2	4DX3	6EA2-M
4DS8-*	6LS2	6DX2	2DY2	4DX2	4EA2-E
4DS8-*	4LS2	4DX2	9DY3	4DX3	4EA2-E
4DS8-*	2LS2	4DX3	9DY3	4DX2	4EA2-M
4DS8-*	2LS3	4DX2	9DY2	4DX3	4EA2-M

* See 9.3.3 for explanation.

* *New or Revised**Continued*

DATE ISSUED: July 31, 2002

EFFECTIVE DATE: September 18, 2002

Aloa J. Stevens
 Director – State Government Affairs
 Citizens Communications Company
 4 Triad Center, Suite 200
 Salt Lake City, Utah 84180

ACCESS SERVICE

9. Interface Groups, Transmission Specifications, and Channel Codes (Cont'd)9.3 Channel Interface and Network Channel Codes (Cont'd)9.3.5 Compatible Channel Interfaces (Cont'd)(C) Voice Grade (Cont'd)

<u>Compatible CIs</u>		<u>Compatible CIs</u>		<u>Compatible CIs</u>	
6DX2	8EB2-E	4DX2	6LS2	9DY2	6DY3
6DX2	8EB2-M	4DX3	6LS2	9DY3	4DY2
6DX2	6EB2-E	4DX3	4LS2	9DY2	4DY2
6DX2	6EB2-M	4DX2	4LS2	9DY2	2DY2
4DX2	8EB2-E	4DX3	2LS3	9DY3	2DY2
4DX2	8EB2-M	4DX2	2LS3	6DY3	6DY3
4DX3	8EB2-E	4DX3	2LS2	6DY3	6DY2
4DX3	8EB2-M	4DX2	2LS2	6DY2	6DY2
4DX2	6EB2-E	2DX3	2LS2	6DY3	4DY2
4DX2	6EB2-M	2DX3	2LS3	6DY3	2DY2
4DX3	6E82-E			6DY2	4DY2
4DX3	6EB2-M	4DX3	4RV2-T	6DY2	2DY2
		4DX2	4RV2-T	4DY2	2DY2
4DX2	2LA2	4DX3	2RV2-T	4DY2	4DY2
4DX3	2LA2	4DX2	2RV2-T		
2DX3	2LA2			6EA2-E	4AC2
		6DX2	4SF2	6EA2-M	4AC2
4DX2	2LB2	4DX2	4SF2	6EA2-E	2AC2
4DX3	2LB2	4DX3	4SF2	6EA2-M	2AC2
2DX3	2LB2	4DX2	4SF3		
		4DX3	4SF3	9EA2	9DY3
4DX2	2LC2			9EA2	9DY2
4DX3	2LC2	9DY3	9DY3	9EA2	6DY3
2DX3	2LC2	9DY3	9DY2	9EA2	6DY2
		9DY2	9DY2	9EA2	4DY2
4DX2	2LO3	9DY3	6DY3	9EA2	2DY2
4DX3	2LO3	9DY3	6DY2	9EA3	9DY3
2DX3	2LO3	9DY2	6DY2		

* *New or Revised**Continued*

DATE ISSUED: July 31, 2002

EFFECTIVE DATE: September 18, 2002

Aloa J. Stevens
 Director – State Government Affairs
 Citizens Communications Company
 4 Triad Center, Suite 200
 Salt Lake City, Utah 84180

ACCESS SERVICE

9. Interface Groups, Transmission Specifications, and Channel Codes (Cont'd)

9.3 Channel Interface and Network Channel Codes (Cont'd)

9.3.5 Compatible Channel Interfaces (Cont'd)

(C) Voice Grade (Cont'd)

<u>Compatible CIs</u>		<u>Compatible CIs</u>		<u>Compatible CIs</u>	
9EA3	9DY2	4EA2-M	9DY2	4EA3-E	9EA2
9EA3	6DY3	4EA2-M	6DY3	4EA3-E	9EA3
9EA3	6DY2	4EA2-M	6DY2	4EA2-M	4EA2-M
9EA3	4DY2	4EA2-M	4DY2		
9EA3	2DY2	4EA2-M	2DY2	9EA2	8EB2-E
6EA2-E	9DY3			9EA2	8EB2-M
6EA2-E	9DY2	9EA2	9EA2	9EA2	6EB2-E
6EA2-E	6DY3	9EA2	9EA3	9EA2	6EB2-M
6EA2-E	6DY2	9EA2	6EA2-E	9EA3	8EB2-E
6EA2-E	4DY2	9EA2	6EA2-M	9EA3	8E82-M
6EA2-E	2DY2	9EA2	4EA2-E	9EA3	6EB2-E
6EA2-M	9DY3	9EA2	4EA2-M	9EA3	6EB2-M
6EA2-M	9DY2	9EA3	9EA3	6EA2-E	8EB2-E
6EA2-M	6DY3	9EA3	6EA2-E	6EA2-E	8EB2-M
6EA2-M	6DY2	9EA3	6EA2-M	6EA2-E	6EB2-E
6EA2-M	4DY2	9EA3	4EA2-E	6EA2-E	6EB2-M
6EA2-M	2DY2	9EA3	4EA2-M	6EA2-M	8EB2-E
4EA2-E	9DY3	6EA2-E	6EA2-E	6EA2-M	8E82-M
4EA2-E	9DY2	6EA2-E	6EA2-M	6EA2-M	6EB2-E
4EA3-E	9DY3	6EA2-M	6EA2-M	6EA2-M	6EB2-M
4EA3-E	9DY2	6EA2-E	4EA2-E	4EA2-E	8EB2-E
4EA3-E	6DY3	6EA2-E	4EA2-M	4EA2-E	8EB2-M
4EA3-E	6DY2	6EA2-M	4EA2-E	4EA3-E	8EB2-E
4EA3-E	4DY2	6EA2-M	4EA2-M	4EA3-E	8E82-M
4EA3-E	2DY2	4EA2-E	4EA2-E	4EA2-E	6EB2-E
4EA2-E	6DY3	4EA3-E	6EA2-E	4EA2-E	6EB2-M
4EA2-E	6DY2	4EA3-E	6EA2-M	4EA3-E	6EB2-E
4EA2-E	4DY2	4EA3-E	4EA2-E	4EA3-E	6EB2-M
4EA2-E	2DY2	4EA3-E	4EA2-M	4EA2-M	8EB2-E
4EA2-M	9DY3	4EA2-E	4EA2-M		

* New or Revised

Continued

DATE ISSUED: July 31, 2002

EFFECTIVE DATE: September 18, 2002

Aloa J. Stevens
Director – State Government Affairs
Citizens Communications Company
4 Triad Center, Suite 200
Salt Lake City, Utah 84180

ACCESS SERVICE

9. Interface Groups, Transmission Specifications, and Channel Codes (Cont'd)9.3 Channel Interface and Network Channel Codes (Cont'd)9.3.5 Compatible Channel Interfaces (Cont'd)(C) Voice Grade (Cont'd)

<u>Compatible CIs</u>		<u>Compatible CIs</u>		<u>Compatible CIs</u>	
4EA2-M	8EB2-M	9EA3	43F2	6EB3-E	9DY2
4EA2-M	6EB2-E	9EA2	4SF2	6EB3-E	9DY3
4EA2-M	6EB2-M	6EA2-E	4SF3	6EB2-E	6DY2
		6EA2-M	4SF3	6EB3-E	6DY2
6EA2-E	2LA2	6EA2-E	4SF2	6EB2-E	6DY3
6EA2-M	2LA2	6EA2-M	4SF2	6EB3-E	6DY3
		4EA3-E	4SF2	6EB2-E	4DY2
6EA2-E	2LB2	4EA2-E	4SF2	6EB3-E	2DY2
6EA2-M	2LB2	4EA2-M	4SF2	6EB3-E	4DY2
				6EB2-M	9DY2
6EA2-E	2LC2	8EB2-E	4AC2	6EB2-M	9DY3
6EA2-M	2LC2	8EB2-M	4AC2	6EB2-M	6DY2
		8EB2-E	2AC2	6EB2-M	6DY3
6EA2-E	2LO3	8EB2-M	2AC2	6EB2-M	4DY2
6EA2-M	2LO3			6EB2-E	2DY2
		8EB2-E	9DY3	6EB2-M	2DY2
6EA2-E	6LS2	8EB2-E	9DY2		
6EA2-M	6LS2	8EB2-E	6DY3	6EB3-E	9EA2
6EA2-E	4LS2	8EB2-E	6DY2	6EB3-E	9EA3
6EA2-M	4LS2	8EB2-E	4DY2	6EB3-E	6EA2-E
6EA2-E	2LS2	8EB2-E	2DY2	6EB3-E	6EA2-M
6EA2-M	2LS2	8EB2-M	9DY3	6EB3-E	4EA2-E
6EA2-E	2LS3	8EB2-M	9DY2	6EB3-E	4EA2-M
6EA2-M	2LS3	8EB2-M	6DY3		
		8EB2-M	6DY2	8EB2-E	8EB2-E
6EA2-E	4RV2-T	8EB2-M	4DY2	8EB2-E	8EB2-M
6EA2-M	4RV2-T	8EB2-M	2DY2	8EB2-M	8EB2-M
6EA2-E	2RV2-T	6EB2-E	9DY2	8EB2-E	6EB2-E
6EA2-M	2RV2-T	6EB2-E	9DY3	8EB2-E	6EB2-M

* *New or Revised**Continued*

DATE ISSUED: July 31, 2002

EFFECTIVE DATE: September 18, 2002

Aloa J. Stevens
 Director – State Government Affairs
 Citizens Communications Company
 4 Triad Center, Suite 200
 Salt Lake City, Utah 84180

ACCESS SERVICE

9. Interface Groups, Transmission Specifications, and Channel Codes (Cont'd)9.3 Channel Interface and Network Channel Codes (Cont'd)9.3.5 Compatible Channel Interfaces (Cont'd)(C) Voice Grade (Cont'd)

<u>Compatible CIs</u>		<u>Compatible CIs</u>		<u>Compatible CIs</u>	
8EB2-M	6EB2-E	8EB2-E	4RV2-T	8EC2	8EB2-M
8EB2-M	6EB2-M	8EB2-M	4RV2-T	8EC2	6EB2-E
6EB2-E	6EB2-E	8EB2-E	2RV2-T	8EC2	6EB2-M
6EB2-E	6EB2-M	8EB2-M	2RV2-T		
6EB3-E	8EB2-E			8EC2	4SF2
6EB3-E	8EB2-M	8EB2-E	4SF2	6EX2-B	2GO3
6EB2-M	6EB2-M	8EB2-M	4SF2	6EX2-A	6GS2
		8EB2-E	4SF3	6EX2-A	4GS2
8EB2-E	2LA2	8EB2-M	4SF3	6EX2-A	2GS2
8EB2-M	2LA2	6EB3-E	4SF2	6EX2-A	2GS3
		6EB2-E	4SF2		
8EB2-E	2LB2	6EB2-M	4SF2	6EX2-B	2LA2
8EB2-M	2LB2				
		8EC2	9DY2	6EX2-B	2LB2
8EB2-E	2LC2	8EC2	9DY3		
8EB2-M	2LC2	8EC2	6DY2	6EX2-B	2LC2
		84C2	6DY3		
8EB2-E	2LO3	8EC2	4DY2	6EX2-B	2LO2
8EB2-M	2LO3	8EC2	2DY2	6EX2-B	2LO3
8EB2-E	6LS2	8EC2	9EA2	6EX2-B	4LR2
8EB2-M	6LS2	8EC2	9EA3	6EX2-B	2LR2
8EB2-E	4LS2	8EC2	6EA2-E		
8EB2-M	4LS2	8EC2	6EA2-M	6EX2-A	6LS2
8EB2-E	2LS2	8EC2	4EA2-E	6EX2-A	4LS2
8EB2-M	2LS2	8EC2	4EA2-M	6EX2-A	2LS2
8EB2-E	2LS3			6EX2-A	2LS3
8EB2-M	2LS3	8EC2	8EB2-E		

* New or Revised

Continued

DATE ISSUED: July 31, 2002

EFFECTIVE DATE: September 18, 2002

Aloa J. Stevens
 Director – State Government Affairs
 Citizens Communications Company
 4 Triad Center, Suite 200
 Salt Lake City, Utah 84180

ACCESS SERVICE

9. Interface Groups, Transmission Specifications, and Channel Codes (Cont'd)9.3 Channel Interface and Network Channel Codes (Cont'd)9.3.5 Compatible Channel Interfaces (Cont'd)(C) Voice Grade (Cont'd)

<u>Compatible CIs</u>		<u>Compatible CIs</u>		<u>Compatible CIs</u>	
6EX2-A	4SF2	6LO2	6LS2	4LR2	4SF2
6EX2-B	4SF2	6LO2	4LS2	4LR3	4SF2
		6LO2	2LS2		
6GO2	6GS2	6LO2	2LS3	6LS2	2LA2
6GO2	4GS2	4LO2	6LS2	4LS2	2LA2
6GO2	2GS2	4LO2	4LS2	4LS3	2LA2
6GO2	2GS3	4LO3	6LS2	2LS2	2LA2
4GO2	6GS2	4LO3	4LS2	2LS3	2LA2
4GO3	6GS2	4LO3	2LS3		
4GO2	4GS2	4LO3	2LS2	6LS2	2LB2
4GO3	4GS2	4LO2	2LS2	4LS2	2LB2
4GO2	2GS2	4LO2	2LS3	4LS3	2LB2
4GO2	2GS3	2LO3	2LS3	2LS2	2LB2
4GO3	2GS2	2LO3	2LS2	2LS3	2LB2
4GO3	2GS3	2LO2	2LS2		
2GO2	2GS2	2LO2	2LS3	6LS2	2LC2
2GO3	2GS2		4LS2	2LC2	
2GO2	2GS3	6LO2	4SF2	4LS3	2LC2
2GO3	2GS3	4LO2	4SF2	2LS2	2LC2
		4LO3	4SF2	2LS3	2LC2
6GO2	4SF2				
4GO2	4SF2	4LR2	4LR1	6LS2	2LO3
4GO3	4SF2	4LR3	2LR2	6LS2	2LO2
		4LR2	4LR2	4LS2	2LO2
6GS2	2GO2	4LR2	2LR2	4LS2	2LO3
4GS2	2GO2	2LR2	2LR2	4LS3	2LO2
4GS3	2GO2	2LR3	2LR2	4LS3	2LO3
4GS2	2GO3				

* *New or Revised**Continued*

DATE ISSUED: July 31, 2002

EFFECTIVE DATE: September 18, 2002

Aloa J. Stevens
 Director – State Government Affairs
 Citizens Communications Company
 4 Triad Center, Suite 200
 Salt Lake City, Utah 84180

ACCESS SERVICE

9. Interface Groups, Transmission Specifications, and Channel Codes (Cont'd)9.3 Channel Interface and Network Channel Codes (Cont'd)9.3.5 Compatible Channel Interfaces (Cont'd)(C) Voice Grade (Cont'd)

<u>Compatible CIs</u>		<u>Compatible CIs</u>		<u>Compatible CIs</u>	
6LS2	4SF2	4SF3	9DY2	4SF3	2LA2
4LS3	4SF2	4SF2	9DY3		
		4SF3	6DY3	4SF2	2LB2
4NO2	6DA2	4SF2	6DY3	4SF3	2LB2
4NO2	4DA2	4SF2	6DY3		
4NO2	2DA2	4SF3	6DY2	4SF2	2LC2
2NO2	2DA2	4SF2	4DY2	4SF3	2LC2
		4SF3	4DY2		
4NO2	4DE2	4SF3	2DY2	4SF2	2LO3
4NO2	2DE2	4SF2	2DY2	4SF3	2LO3
4NO2	4NO2	4SF3	9EA2	4SF2	2LR2
4NO2	2NO2	4SF3	9EA3	4SF3	4LR2
2NO2	2NO2	4SF3	4EA2-E	4SF3	2LR2
2NO3	2NO2	4SF3	4EA2-M		
				4SF3	6LS2
2NO3	2PR2	4SF3	6EB2-E	4SF2	4LS2
		4SF3	6EB2-M	4SF3	4LS2
4RV2-0	4RV2-T	4SF3	2GO3	4SF2	2LS2
4RV2-0	2RV2-T	4SF3	6GS2	4SF2	2LS3
4RV2-0	2RV2-T	4SF2	6GS2	4SF3	2LS2
		4SF2	6GS2	4SF3	2LS3
4RV2-0	4SF2	4SF3	4GS2		
		4SF2	2GS2	4SF3	4RV2-T
4SF2	4AC2	4SF2	2GS3	4SF2	4RV2-T
4SF2	2AC2	4SF3	2GS2	4SF2	2RV2-T
		4SF3	2GS3	4SF3	2RV2-T
4SF3	9DY3				
4SF2	9DY2	4SF2	2LA2	4SF3	4SF3

* *New or Revised**Continued*

DATE ISSUED: July 31, 2002

EFFECTIVE DATE: September 18, 2002

Aloa J. Stevens
 Director – State Government Affairs
 Citizens Communications Company
 4 Triad Center, Suite 200
 Salt Lake City, Utah 84180

ACCESS SERVICE9. Interface Groups, Transmission Specifications, and Channel Codes (Cont'd)9.3 Channel Interface and Network Channel Codes (Cont'd)9.3.5 Compatible Channel Interfaces (Cont'd)(C) Voice Grade (Cont'd)Compatible CIs

4SF3	4SF2
4SF2	4SF2

4TF2	4TF2
4TF2	2TF2
2TF3	2TF2

(D) Program AudioCompatible CIs

4AH5-B	2PG1-3
4AH5-B	2PG1-5
4AH5-B	2PG1-8
4AH5-B	2PG2-3
4AH5-B	2PG2-5
4AH5-B	2PG2-8
4AH6-C	2PG1-3
4AH6-C	2PG1-5
4AH6-C	2PG1-8
4AH6-C	2PG2-3
8AH6-C	2PG2-5

Compatible CIs

4AH6-D	2PG1-3
4AH6-D	2PG1-5
4AH6-D	2PG1-8
4AH6-D	2PG2-3
4AH6-D	2PG2-5
4AH6-D	2PG2-8
4DS8-15E	2PG1-3
4DS8-15F	2PG1-5
4DS8-15G	2PG1-8
4DS8-15H	2PG1-1
4DS8-15E	2PG2-3

Compatible CIs

4DS8-15F	2PG2-5
4DS8-15G	2PG2-8
4DS8-15H	2PG2-1
2PG2-1	2PG1-1
2PG2-1	2PG2-1
2PG2-3	2PGI-3
2PG2-3	2PG2-3
2PG2-5	2PG1-5
2PG2-5	2PG2-5
2PG2-8	2PG1-8
2PG2-8	2PG2-8

* *New or Revised**Continued*

DATE ISSUED: July 31, 2002

EFFECTIVE DATE: September 18, 2002

Aloa J. Stevens
Director – State Government Affairs
Citizens Communications Company
4 Triad Center, Suite 200
Salt Lake City, Utah 84180

ACCESS SERVICE

9. Interface Groups, Transmission Specifications, and Channel Codes (Cont'd)

9.3 Channel Interface and Network Channel Codes (Cont'd)

9.3.5 Compatible Channel Interfaces (Cont'd)

(E) Video

<u>Compatible CIs</u>		<u>Compatible CIs</u>	
2TV6-1	4TV6-15	4TV7-5	4TV6-5
	4TV7-15		4TV7-5
2TV6-2	6TV6-15	4TV7-15	4TV6-15
	6TV7-15		4TV7-15
2TV7-1	4TV6-15	6TV6-5	6TV6-5
	4TV7-15		6TV7-5
2TV7-2	6TV6-15	6TV6-15	6TV6-15
	6TV7-15		6TV7-15
4TV6-5	4TV6-5	6TV7-5	6TV6-5
		4TV7-5	6TV7-5
4TV6-15	4TV6-15	6TV7-15	6TV6-15
	4TV7-15		6TV7-15

(F) Wideband Analog

<u>Compatible CIs</u>		<u>Compatible CIs</u>		<u>Compatible CIs</u>	
4AH5-B	4AH5-B			4WD5-1	4WA5-1
4AH6-C	4AH5-B			4WD5-2	4WA5-1
4AH6-C	4AH6-C	4AH6-D	4AH6-D	4WD5-3	4WA5-2
	4AH6-D	4AH5-B	4AH5-B	4DS8-15	
	4AH6-D	4AH6-C	4AH5-B	4DU8-A,B, or C	
	4AH6-C	4DU8-A,B, or C			
		4AH6-D	4DU8-A,B, or C		

* *New or Revised*

Continued

DATE ISSUED: July 31, 2002

EFFECTIVE DATE: September 18, 2002

Aloa J. Stevens
Director – State Government Affairs
Citizens Communications Company
4 Triad Center, Suite 200
Salt Lake City, Utah 84180

ACCESS SERVICE

9. Interface Groups, Transmission Specifications, and Channel Codes (Cont'd)9.3 Channel Interface and Network Channel Codes (Cont'd)9.3.5 Compatible Channel Interfaces (Cont'd)(G) Wideband Data

<u>Compatible Cls</u>		<u>Compatible Cls</u>		<u>Compatible Cls</u>	
8WB5-18S	12WC6-18	8WB5-23A	10WC6-23	8WB5-50A	10WC6-50
8WB5-19A	10WC6-19	8WB5-23S	12W6-23S	8WB5-50S	12WB6-50
8WB5-19S	12WC6-19	8WB5-40S	12W6-40		

(H) Digital Data

<u>Compatible Cls</u>		<u>Compatible Cls</u>		<u>Compatible Cls</u>	
			4DS8-15	6DU5-48	
4DS8-15	4DU8-15*	4DS8-15	6DU5-56	4DU5-96	4DU5-96
4DS8-15	4DU8-24	4DS8-15	6DU5-96	6DU5-24	6DU5-24
4DS8-15	4DU8-48	4DU5-24	4DU5-24	6DU5-48	6DU5-48
4DS8-15	4DU8-56	4DU5-48	4DU5-48	6DU5-56	6DU5-56
4DS8-15	6DU5-96	4DU8-56	4DU5-56	6DU5-96	6DU5-96
4DS8-15	6DU5-24				

(I) High Capacity

<u>Compatible Cls</u>		<u>Compatible Cls</u>	
		4DS8-15	4DU8-8
4DSO-63	4DSO-63	4DS8-15J	6DU8-A
4DSO-63	6DU8-A,B or C	4DS8-15J	4DU8-A
4DSO-63	4DU8-A,B or C	4DS8-15K	6DU8-B
4DS6-27	4DS6-27	4DS8-15K	4DU8-B
4DS6-27	6DU8-A,B or C	4DS8-15K	6DU8-C
4DS6-27	4DU8-A,B or C	4DS8-15K	4D78-C
4DS6-44	4DS6-44	4DS9-31	4DS9-31
4DS6-44	6DU8-A,B or C	4DS9-31	6DU8-A,B or C
4DS6-44	4DU8-A,B or C	4DS9	4DU8-A,B or C
4DS8-15	4DS8-15+	4DU9-A,B or C	4DU8-A,B or C
4DS8-15	6DU8-B		

* Available only as a cross connect of two digital circuits at appropriate digital speeds at a Telephone Company hub.

+ Available only as a cross connect of two individual circuits of 1.544 Mbps

* *New or Revised*

Continued

DATE ISSUED: July 31, 2002

EFFECTIVE DATE: September 18, 2002

Aloa J. Stevens
Director – State Government Affairs
Citizens Communications Company
4 Triad Center, Suite 200
Salt Lake City, Utah 84180

ACCESS SERVICE

10. Special Federal Government Access Services

10.1 General

This section covers Special Access Services that are provided to a customer for use only by agencies or branches of the Federal Government and other users authorized by the Federal Government. Services provided to state emergency operations centers are included. These services provide for command and control communications, including communications for national security, emergency preparedness and presidential requirements. They are required to assure continuity of Government in emergency and crisis situations and to provide for national security.

Services for command and control communications and for national security and emergency preparedness sometimes require short notice and short duration service provisions. These provisions are especially needed to meet presidential requirements or in response to natural, man-made, or declared emergencies. Requirements of this type cannot be forecasted and are usually needed for a relatively short period. The provision of service under these conditions may require the availability of facilities, such as portable microwave equipment, which are provided on a temporary basis by the Telephone Company or customer. Rates for these services can be found in Section 16.4 following.

10.2 Emergency Conditions

These services will be provided on the date requested or as soon as possible thereafter when the emergency falls into one of the following categories:

- State of crisis declared by the National Command Authorities (includes commitments made to the National Communications System in the "National Plan for Emergencies and Major Disasters").

** New or Revised*

Continued

DATE ISSUED: July 31, 2002

EFFECTIVE DATE: September 18, 2002

Aloa J. Stevens
Director – State Government Affairs
Citizens Communications Company
4 Triad Center, Suite 200
Salt Lake City, Utah 84180

ACCESS SERVICE

10. Special Federal Government Access Services (Cont'd)

10.2 Emergency Conditions (Cont'd)

- Efforts to protect endangered U.S. personnel or property both in the U.S. and abroad. (Includes space vehicle recovery and protection efforts.)
- Communications requirements resulting from hostile action, a major disaster or a major civil disturbance.
- The director (Cabinet level) of a Federal department, Commander of a Unified/Specified Command, or head of a military department has certified that a communications requirement is so critical to the protection of life and property or to the National Defense that it must be processed immediately.
- Political unrest in foreign countries which affect the national interest.
- Presidential service.

10.3 Intervals to Provide Service

Services provided under the provisions of this section of the tariff are provided on an individual case basis. Therefore, orders for such service shall be placed under the Negotiated Interval provisions set forth in Section 5.1.7 preceding.

10.4 Safeguarding of Service

10.4.1 Facility Availability

In order to insure communications during periods of emergency, the Telephone Company will, within the limits of good management, make available the necessary facilities to restore service in the event of damage or to provide temporary emergency service.

** New or Revised*

Continued

DATE ISSUED: July 31, 2002

EFFECTIVE DATE: September 18, 2002

Aloa J. Stevens
Director – State Government Affairs
Citizens Communications Company
4 Triad Center, Suite 200
Salt Lake City, Utah 84180

ACCESS SERVICE

10. Special Federal Government Access Services (Cont'd)

10.4 Safeguarding of Service (Cont'd)

10.4.1 Facility Availability (Cont'd)

In order to meet the requirements of agencies or branches of the Federal Government, the Telephone Company may utilize government-owned facilities, when necessary to provide service.

10.5 Federal Government Regulations

In accordance with Federal Government Regulations, all service provided to the Federal Government will be billed in arrears. However, this provision does not apply to other customers that obtain services under the provisions of this tariff to provide their services to the Federal Government.

10.6 Service Offerings to the Federal Government

The following unique services are provided to a customer for use only by agencies or branches of the Federal Government, other authorized users and state emergency operations centers. The rates and charges for these services shall be developed on an individual case basis and shall be consistent with the rates and charges for services offered in other sections of this tariff.

10.6.1 Type and Description

(A) Voice Grade Special Access Services

(1) Voice Grade Secure Communications Type I

Approximate bandwidth of 10-50,000 Hz. Furnished for two-point secure communications on two-wire or four-wire metallic facilities between an IC premise and an end user premise. Services are conditioned as follows:

** New or Revised*

Continued

DATE ISSUED: July 31, 2002

EFFECTIVE DATE: September 18, 2002

Aloa J. Stevens
Director – State Government Affairs
Citizens Communications Company
4 Triad Center, Suite 200
Salt Lake City, Utah 84180

ACCESS SERVICE

10. Special Federal Government Access Services (Cont'd)10.6 Service Offerings to the Federal Government (Cont'd)10.6.1 Type and Description (Cont'd)(A) Voice Grade Special Access Services (Cont'd)(1) Voice Grade Secure Communications Type I (Cont'd)

T-3 Conditioning - The absolute loss (referenced to 1 milliwatt) with respect to frequency shall not exceed:

15 dB at 10 Hz
 13 dB at 100 Hz
 9 dB at 1,000 Hz
 20 dB at 10,000 Hz
 30 dB at 50,000 Hz

Additional conditioning (available in one or two directions on four-wire facilities only) to provide the following characteristics:

The absolute loss (referenced to one milliwatt) with respect to frequency shall not exceed:

0 db at 1,000 Hz
 ± 1 dB between 1,000 Hz and 40,000 Hz
 ± 2 dB between 10 Hz and 50,000 Hz
 (+ means more loss)

The net loss of the conditioned service (with or without additional conditioning) shall not vary by more than four dB at 1,000 Hz from the levels specified above. Voice frequency signaling or supervisory tones can be transmitted.

* *New or Revised**Continued*

DATE ISSUED: July 31, 2002

EFFECTIVE DATE: September 18, 2002

Aloa J. Stevens
 Director – State Government Affairs
 Citizens Communications Company
 4 Triad Center, Suite 200
 Salt Lake City, Utah 84180

ACCESS SERVICE

10. Special Federal Government Access Services (Cont'd)

10.6 Service Offerings to the Federal Government (Cont'd)

10.6.1 Type and Description (Cont'd)

(A) Voice Grade Special Access Services (Cont'd)

(2) Voice Grade Secure Communications Type II

Approximate bandwidth 10-50,000 Hz. Furnished on four-wire metallic facilities for duplex operation for two-point secure communications between an IC premise and an end user premise or an end user premise and an end user premise. Services are conditioned as follows:

G-1 Conditioning - The absolute loss with respect to frequency and the net loss variation shall be the same as Voice Grade Secure Communications Type I services without additional conditioning. Voice frequency signaling or supervisory tones can be transmitted.

(3) Voice Grade Secure Communications Type III

Approximate bandwidth 10-50,000 Hz. Furnished on four-wire metallic facilities for duplex operation for two-point secure communications between an IC premises switch and an end user premise. Services are conditioned as follows:

G-2 Conditioning - The absolute loss with respect to frequency and the net loss variation from the switch to an end user premise shall be the same as Voice Grade Secure Communications Type I services without additional conditioning; from an end user premise to the switch shall be the same as Voice Grade Secure Communications Type I services with additional conditioning. Voice frequency signaling or supervisory tones can be transmitted.

** New or Revised*

Continued

DATE ISSUED: July 31, 2002

EFFECTIVE DATE: September 18, 2002

Aloa J. Stevens
Director – State Government Affairs
Citizens Communications Company
4 Triad Center, Suite 200
Salt Lake City, Utah 84180

ACCESS SERVICE

10. Special Federal Government Access Services (Cont'd)

10.6 Service Offerings to the Federal Government (Cont'd)

10.6.1 Type and Description (Cont'd)

(A) Voice Grade Special Access Services (Cont'd)

(4) Voice Grade Secure Communications Type IV

Approximate bandwidth 10-50,000 Hz. Furnished on four-wire metallic facilities for duplex operation for two-point secure communication between two IC premises switches. Services are conditioned as follows:

G-3 Conditioning - The absolute loss with respect to frequency and the net loss variation shall be the same in both directions of transmission as Voice Grade Secure Communications Type I services with additional conditioning. Voice frequency signaling or supervisory tones can be transmitted.

(B) Wideband Digital Special Access Service

Service arrangements for secured communications to accommodate the transmission of binary digital baseband signals in a random polar format.

(1) Wideband Secure Communications Type I

For transmission at the rate of 18,750 bits per second.

(2) Wideband Secure Communications Type II

For transmission at the rate of 50,000 bits per second.

** New or Revised*

Continued

DATE ISSUED: July 31, 2002

EFFECTIVE DATE: September 18, 2002

Aloa J. Stevens
Director – State Government Affairs
Citizens Communications Company
4 Triad Center, Suite 200
Salt Lake City, Utah 84180

ACCESS SERVICE

10. Special Federal Government Access Services (Cont'd)

10.6 Service Offerings to the Federal Government (Cont'd)

10.6.1 Type and Description

(B) Wideband Digital Special Access Service (Cont'd)

(3) Wideband Secure Communications Type III

To accommodate the transmission of restored polar two-level facsimile signals with a minimum signal element width of twenty microseconds at a rate of 50,000 bits per second.

To accommodate the transmission of binary digital baseband signals in a random polar format at the rate of 50,000 bits per second.

(C) Special Routing Access Service

Special Routing Access Service is furnished only to AT&T Communications (AT&T-C) for an agency or branch of the Federal Government. This service provides the customer's end users the ability to originate and terminate calls to or from the customer's premises utilizing a Special Routing Plan.

This service is an optional service which operates in conjunction with Trunk Side Premium Access Service furnished to AT&T-C under other provisions of this tariff.

10.6.2 Mileage Application

Mileage, when used for rate application between two customer premises, shall be determined by the V & H Coordinates information as set forth in Section 15 of this tariff.

** New or Revised*

Continued

DATE ISSUED: July 31, 2002

EFFECTIVE DATE: September 18, 2002

Aloa J. Stevens
Director – State Government Affairs
Citizens Communications Company
4 Triad Center, Suite 200
Salt Lake City, Utah 84180

ACCESS SERVICE

10. Special Federal Government Access Services (Cont'd)10.6 Service Offerings to the Federal Government (Cont'd)10.6.3 Rates and Charges(A) Voice Grade Special Access Service

The provision of T-3 and G conditioned services contemplates station and tandem switching operations, using customer provided equipment, as well as Special Access Service. Separate narrowband or voice grade services, where required by the customer provided equipment or switching operation, are furnished in accordance with the applicable sections of this tariff. Rates and charges can be found in Section 16.4 following.

(B) Wideband Digital Special Access Service(C) Move Charges

- (1) When service without a termination charge associated with it, as set forth in (A) and (B) preceding, is moved to a different building, the nonrecurring charge applies; when moved to a new location in the same building, a charge of one-half the nonrecurring charge applies.
- (2) When service with a termination charge associated with it, as set forth in (A) and (B) preceding, is moved and is reinstalled at a new location, the customer may elect:
 - to pay the unexpired portion of the termination charge for the service, if any, with the application of nonrecurring charge and the establishment of a new termination charge for such service at the new location, or
 - to continue service subject to the unexpired portion of the termination charge, if any, and pay the estimated costs of moving such service, provided that the customer requests

** New or Revised**Continued*

DATE ISSUED: July 31, 2002

EFFECTIVE DATE: September 18, 2002

Aloa J. Stevens
Director – State Government Affairs
Citizens Communications Company
4 Triad Center, Suite 200
Salt Lake City, Utah 84180

ACCESS SERVICE

10. Special Federal Government Access Services (Cont'd)

10.6 Service Offerings to the Federal Government (Cont'd)

10.6.3 Rates and Charges (Cont'd)

(C) Move Charges (Cont'd)

(2) (Cont'd)

- these charges be quoted prior to ordering the service move. Charges for moving such service will be based on estimated costs attributable to the move.

Move charges include the estimated costs of removal, restoration of services or facilities necessitated by the move, transportation, storage, reinstallation, engineering, labor, supervision, materials, administration, and any other specific items of cost directly attributable to the move.

(D) Special Routing Access Services

The following rates and charges are in addition to all other rates and charges that may be applicable for other services that may be furnished under the provisions of this tariff to operate in conjunction with this service, and can be found in Section 16.4 following.

** New or Revised*

Continued

DATE ISSUED: July 31, 2002

EFFECTIVE DATE: September 18, 2002

Aloa J. Stevens
Director – State Government Affairs
Citizens Communications Company
4 Triad Center, Suite 200
Salt Lake City, Utah 84180

ACCESS SERVICE

11. Special Facilities Routing of Access Services

11.1 Description of Special Facilities Routing of Access Services

The services provided under this tariff are provided over such routes and facilities as the Telephone Company may elect. Special Facilities Routing is involved when, in order to comply with requirements specified by the customer, the Telephone Company provides Switched Access Service, or Special Federal Government Access Service in a manner which includes one or more of the following conditions:

11.1.1 Diversity

Two or more services must be provided over not more than two different physical routes.

11.1.2 Avoidance

A service must be provided on a route which avoids specified geographical locations.

11.1.3 Cable-Only Facilities

Certain Voice Grade services are provided on Cable-Only Facilities to meet the particular needs of a customer.

Service is provided subject to the availability of Cable-Only facilities. In the event of service failure, restoration will be made through the use of any available facilities as selected by the Telephone Company.

Avoidance and Diversity are available on Switched Access Service as set forth in Section 6 preceding; Metallic and Telegraph Grade, Voice Grade and Wideband Analog Special Access Services as set forth in Section 7.3, 7.4, 7.5 and 7.8 preceding and Special Federal Government Access Services as set forth in 10.6 preceding. Cable-Only Facilities are available

** New or Revised*

Continued

DATE ISSUED: July 31, 2002

EFFECTIVE DATE: September 18, 2002

Aloa J. Stevens
Director – State Government Affairs
Citizens Communications Company
4 Triad Center, Suite 200
Salt Lake City, Utah 84180

ACCESS SERVICE

11. Special Facilities Routing of Access Services (Cont'd)

11.1 Description of Special Facilities Routing of Access Services (Cont'd)

11.1.3 Cable-Only Facilities (Cont'd)

for Switched Access Service as set forth in Section 6 preceding; Voice Grade Special Access Services as set forth in Section 7.5 preceding and Special Federal Government Access Services as set forth in Section 10.6 preceding.

In order to avoid the compromise of special routing information, the Telephone Company will provide the required routing information for each specially routed service to only the ordering customer. If requested by the customer, this information will be provided when service is installed and prior to any subsequent changes in routing.

The rates and charges for Special Facilities Routing of Access Services as set forth in 16.5 following are in addition to all other rates and charges that may be applicable for services provided under other sections of this tariff.

11.2 Rates and Charges for Special Facilities Routing of Access Services

The rates and charges for Special Facilities Routing of Access Services are as follows:

11.2.1 Diversity

For each service provided in accordance with 11.2.1 preceding, the rates can be found in Section 16.5.

11.2.2 Avoidance

For each service provided in accordance with 11.2.2 preceding, the rates can be found in Section 16.5.

** New or Revised*

Continued

DATE ISSUED: July 31, 2002

EFFECTIVE DATE: September 18, 2002

Aloa J. Stevens
Director – State Government Affairs
Citizens Communications Company
4 Triad Center, Suite 200
Salt Lake City, Utah 84180

ACCESS SERVICE

11. Special Facilities Routing of Access Services (Cont'd)

11.2 Rates and Charges for Special Facilities Routing of Access Services (Cont'd)

11.2.3 Diversity and Avoidance Combined

For each service provided in accordance with 11.2.3 preceding, the rates can be found in Section 16.5.

11.2.4 Cable-Only Facilities

For each service provided in accordance with 11.2.4 preceding, the rates can be found in Section 16.5.

** New or Revised*

Continued

DATE ISSUED: July 31, 2002

EFFECTIVE DATE: September 18, 2002

Aloa J. Stevens
Director – State Government Affairs
Citizens Communications Company
4 Triad Center, Suite 200
Salt Lake City, Utah 84180

ACCESS SERVICE

12. Specialized Service or Arrangements

12.1 General

Specialized Service or Arrangements may be provided by the Telephone Company, at the request of a customer, on an individual case basis if such service or arrangements meet the following criteria:

- The requested service or arrangements are not offered under other sections of this tariff.
- The facilities utilized to provide the requested service or arrangements are of a type normally used by the Telephone Company in furnishing its other services.
- The requested service or arrangements are provided within a LATA.
- The requested service or arrangements are compatible with other Telephone Company services, facilities, and its engineering and maintenance practices.
- This offering is subject to the availability of the necessary Telephone Company personnel and capital resources.

12.2 Rates and Charges

Rates and charges and additional regulations if applicable, for specialized service or arrangements provided on an individual case basis are filed in Section 16.6.

** New or Revised*

Continued

DATE ISSUED: July 31, 2002

EFFECTIVE DATE: September 18, 2002

Aloa J. Stevens
Director – State Government Affairs
Citizens Communications Company
4 Triad Center, Suite 200
Salt Lake City, Utah 84180

ACCESS SERVICE

13. Exceptions to Access Service Offerings

The services offered under the provisions of this tariff are subject to availability as set forth in 2.1.4 preceding. In addition, the following exceptions apply:

(Paragraphs 13.1 through 13.5 following are reserved for future listing. In the meantime, in planning an end-to-end service, the customer should contact the Telephone Company in each customer premise city to assure itself that all of the services or service components required for a given customer service are currently available).

13.1 The following service(s) is (are) not offered in the operating territory of listed Issuing Carriers.

(Reserved for future use).

13.2 The following offering(s) is (are) limited to existing locations. No inside moves, rearrangements or additions will be permitted.

(Reserve for future use).

13.3 The following offering(s) is (are) limited to existing locations. Inside moves or rearrangements may be undertaken. However, no additions will be permitted.

(Reserve for future use).

13.4 The following offering(s) is (are) limited to existing locations where additional units may be added for growth. Inside moves or rearrangements may be undertaken.

(Reserved for future use).

13.5 The following offering(s) is (are) limited to existing locations where additional units may be added for growth. However inside moves or rearrangements will not be permitted.

(Reserved for future use).

ACCESS SERVICE

14. Special Construction

14.1 Application of Tariff

This section contains regulations, rates, charges, and liabilities applicable for the special construction of intrastate facilities provided by the Telephone Company.

When special construction of facilities is required, the provisions of this section apply in addition to all regulations, rates, and charges set forth in the appropriate service tariff.

14.2 Regulations

14.2.1 Filing of Charges

Rates, charges, and liabilities for special construction to provide facilities for use for one month or more are filed in 14.3 following, as appropriate.

Rates, charges, and liabilities for the construction of facilities for use for less than one month are filed in supplements to this tariff.

14.2.2 Ownership of Facilities

The Telephone Company providing specially constructed facilities under the provisions of this tariff retains ownership of all such facilities.

14.2.3 Interval to Provide Facilities

Based on available information and the type of service ordered, the Telephone Company will establish a completion date for the specially constructed facilities. If the scheduled completion date cannot be met due to circumstances beyond the control of the Telephone Company, a new completion date will be established, and the customer will be notified.

** New or Revised*

Continued

DATE ISSUED: July 31, 2002

EFFECTIVE DATE: September 18, 2002

Aloa J. Stevens
Director – State Government Affairs
Citizens Communications Company
4 Triad Center, Suite 200
Salt Lake City, Utah 84180

ACCESS SERVICE

14. Special Construction (Cont'd)14.2 Regulations (Cont'd)14.2.4 Special Construction Involving Both Interstate and Intrastate Facilities

When special construction involves facilities to be used to provide both interstate and intrastate services, charges for the portion of the construction used to provide interstate service shall be in accordance with this tariff. Charges for the portion of the construction used to provide intrastate service shall be in accordance with the appropriate intrastate tariff.

14.2.5 Payments for Special Construction14.2.5.1 Payment of Charges

All bills associated with special construction charges are due in accordance with the regulations in the appropriate service tariff.

14.2.5.2 Start/End of Billing

Billing of recurring charges for specially constructed facilities starts on the day after the facilities are made available for use. Billing accrues through and includes the day that the specially constructed facilities are discontinued.

14.2.5.3 Credit Allowance for Service Interruptions

In the event of a service interruption involving a specially constructed facility, the customer shall receive a recurring monthly charge credit in accordance with the credit allowance provisions in the appropriate service tariff associated with the affected services.

* *New or Revised*

Continued

DATE ISSUED: July 31, 2002

EFFECTIVE DATE: September 18, 2002

Aloa J. Stevens
Director – State Government Affairs
Citizens Communications Company
4 Triad Center, Suite 200
Salt Lake City, Utah 84180

ACCESS SERVICE

14. Special Construction (Cont'd)

14.2 Regulations (Cont'd)

14.2.5 Payments for Special Construction (Cont'd)

14.2.5.3 Credit Allowance for Service Interruptions (Cont'd)

When an interruption continues due to the failure of the customer to authorize the replacement of facilities subject to a Replacement Charge, as specified in 14.2.6.4(A)(4) following, the credit allowance will be terminated on the seventh calendar day after the Telephone Company has provided the customer with written notification of the need for replacement. The credit allowance will resume on the day after the Telephone Company receives written authorization for the replacement from the customer.

14.2.6 Liabilities and Charges for Special Construction

14.2.6.1 General

This section describes the various charges and liabilities that may apply when the Telephone Company provides special construction of facilities in accordance with an order for service. Written approval of all liabilities and charges must be provided to the Telephone Company prior to the start of construction.

14.2.6.2 Conditions Requiring Special Construction

Special construction is required when (1) facilities are not available to meet an order for service, and (2) the Telephone Company constructs facilities, and (3) one or more of the following conditions exists:

** New or Revised*

Continued

DATE ISSUED: July 31, 2002

EFFECTIVE DATE: September 18, 2002

Aloa J. Stevens
Director – State Government Affairs
Citizens Communications Company
4 Triad Center, Suite 200
Salt Lake City, Utah 84180

ACCESS SERVICE

14. Special Construction (Cont'd)14.2 Regulations (Cont'd)14.2.6 Liabilities and Charges for Special Construction (Cont'd)14.2.6.2 Conditions Requiring Special Construction (Cont'd)

- The Telephone Company has no other requirement for the facilities requested.
- It is requested that service be furnished using a type of facility, or via a route, other than that which the Telephone Company would normally utilize in furnishing the requested service.
- More facilities are requested than would normally be required to satisfy an order.
- It is requested that construction be expedited, resulting in added cost to the Telephone Company.

14.2.6.3 Development of Liabilities and Charges

Special construction charges and liabilities will be developed based on estimated costs, except when actual costs are requested in writing prior to the start of special construction.

In order to meet a scheduled service date when actual costs are requested, an initial special construction filing may be made based on estimated costs. Such a filing will be revised when actual costs are available.

* *New or Revised*

Continued

DATE ISSUED: July 31, 2002

EFFECTIVE DATE: September 18, 2002

Aloa J. Stevens
Director – State Government Affairs
Citizens Communications Company
4 Triad Center, Suite 200
Salt Lake City, Utah 84180

ACCESS SERVICE

14. Special Construction (Cont'd)14.2 Regulations (Cont'd)14.2.6 Liabilities and Charges for Special Construction (Cont'd)14.2.6.4 Types of Liabilities and Charges

Depending on the specifics associated with each individual case, one or more of the following special construction charges and/or liabilities may be applicable:

(A) Nonrecurring Charge

A nonrecurring charge always applies and includes one or more of the following components:

(1) Case Preparation Charge

A nonrecurring charge always includes a case preparation charge component to cover the administrative expenses associated with preparing a special construction case and the associated tariff filing.

(2) Expediting Charge

A nonrecurring charge may include an expediting charge when it is requested that special construction be completed on an expedited basis. The charge equals the difference in estimated cost between expedited and nonexpedited construction.

* *New or Revised*

Continued

DATE ISSUED: July 31, 2002

EFFECTIVE DATE: September 18, 2002

Aloa J. Stevens
Director – State Government Affairs
Citizens Communications Company
4 Triad Center, Suite 200
Salt Lake City, Utah 84180

ACCESS SERVICE

14. Special Construction (Cont'd)14.2 Regulations (Cont'd)14.2.6 Liabilities and Charges for Special Construction (Cont'd)14.2.6.4 Types of Liabilities and Charges (Cont'd)(A) Nonrecurring Charge (Cont'd)(3) Optional Payment

An optional payment charge may be included in the nonrecurring charge in association with a type of facility or route other than that which the Telephone Company would normally use in furnishing the requested service if lower recurring monthly charges are desired for the specially constructed facilities. This charge is equal to the excess installed cost or the total nonrecoverable cost, whichever is less. This election must be made in writing before special construction starts. If this election is coupled with the actual cost option, the optional payment charge will reflect the actual cost of the specially constructed facilities.

(4) Replacement Charge

If any portion of specially constructed facilities for which an optional payment charge has been paid requires replacement involving capital investment, a replacement charge will apply. This charge will be in the same ratio to the total replacement cost as the initial

** New or Revised**Continued*

DATE ISSUED: July 31, 2002

EFFECTIVE DATE: September 18, 2002

Aloa J. Stevens
Director – State Government Affairs
Citizens Communications Company
4 Triad Center, Suite 200
Salt Lake City, Utah 84180

ACCESS SERVICE

14. Special Construction (Cont'd)14.2 Regulations (Cont'd)14.2.6 Liabilities and Charges for Special Construction (Cont'd)14.2.6.4 Types of Liabilities and Charges (Cont'd)(A) Nonrecurring Charge (Cont'd)(4) Replacement Charge (Cont'd)

optional payment charge was to the installed cost of the original specially constructed facilities. If any portion of the facilities subject to the replacement charge fails, service will not be restored until notification is provided in writing that replacement is required and such replacement is ordered.

(5) Rearrangement Charge

If the Telephone Company is requested to rearrange existing specially constructed facilities, a nonrecurring charge equal to the cost of any additional special construction will apply.

(6) Special Construction of Facilities for Use for Less Than One Month

When the Telephone Company is requested to construct facilities to provide service for less than one month, a nonrecurring charge only applies. In addition to the case preparation charge component, this nonrecurring charge recovers all elements of cost, including engineering, shipping of equipment,

* *New or Revised*

Continued

DATE ISSUED: July 31, 2002

EFFECTIVE DATE: September 18, 2002

Aloa J. Stevens
Director – State Government Affairs
Citizens Communications Company
4 Triad Center, Suite 200
Salt Lake City, Utah 84180

ACCESS SERVICE

14. Special Construction (Cont'd)14.2 Regulations (Cont'd)14.2.6 Liabilities and Charges for Special Construction (Cont'd)14.2.6.4 Types of Liabilities and Charges (Cont'd)(A) Nonrecurring Charge (Cont'd)(6) Special Construction of Facilities for Use for Less Than One Month (Cont'd)

equipment installation, lineup, equipment leasing, space rental, equipment removal, and any other costs associated with the construction of the facilities.

(B) Maximum Termination Liability and Termination Charge

A Maximum Termination Liability is equal to the nonrecoverable costs associated with specially constructed facilities and is the maximum amount which could be applied as a Termination Charge if all specially constructed facilities were discontinued before the Maximum Termination Liability expires.

The liability period is equal to the average life of the account associated with the specially constructed facilities. The liability period is generally expressed in terms of an effective and expiration date.

The Maximum Termination Liability is filed with the initial tariff filing in decreasing amounts at ten-year intervals over the average account life

* *New or Revised*

Continued

DATE ISSUED: July 31, 2002

EFFECTIVE DATE: September 18, 2002

Aloa J. Stevens
Director – State Government Affairs
Citizens Communications Company
4 Triad Center, Suite 200
Salt Lake City, Utah 84180

ACCESS SERVICE

14. Special Construction (Cont'd)14.2 Regulations (Cont'd)14.2.6 Liabilities and Charges for Special Construction (Cont'd)14.2.6.4 Types of Liabilities and Charges (Cont'd)(B) Maximum Termination Liability and Termination Charge (Cont'd)

of the facilities. In the event that the average account life of the facilities is not an even multiple of ten, the last increment will reflect the appropriate number of years remaining.

Example Illustrating a 27-Year Average Account Life

<u>Maximum Termination Liability</u>	<u>Effective Date</u>	<u>Expiration Date</u>
\$10,000	6/1/84	6/1/94
7,000	6/1/94	6/1/04
3,000	6/1/04	6/1/11

Prior to the expiration of each liability period, the customer has the option to (A) terminate the special construction case and pay the appropriate charges, or (B) extend the use of the specially constructed facilities for the new liability period.

The Telephone Company will notify the customer six months in advance of the expiration date of each ten-year liability period. The customer must provide the Telephone Company with written notification at least 30

* *New or Revised**Continued*

DATE ISSUED: July 31, 2002

EFFECTIVE DATE: September 18, 2002

Aloa J. Stevens
Director – State Government Affairs
Citizens Communications Company
4 Triad Center, Suite 200
Salt Lake City, Utah 84180

ACCESS SERVICE

14. Special Construction (Cont'd)14.2 Regulations (Cont'd)14.2.6 Liabilities and Charges for Special Construction (Cont'd)14.2.6.4 Types of Liabilities and Charges (Cont'd)(B) Maximum Termination Liability and Termination Charge (Cont'd)

days prior to the expiration of the liability period if termination is elected. Failure to do so will result in an automatic extension of the special construction case to the next liability period at the filed Maximum Termination Liability amount.

A Termination Charge may apply when all services using specially constructed facilities which have a tariffed Maximum Termination Liability are discontinued prior to the expiration of the liability period. The charge reflects the unamortized portion of the nonrecoverable costs at the time of termination, adjusted for net salvage and possible reuse. Administrative costs associated with the specific case of special construction and any cost for restoring a location to its original condition are also included. A Termination Charge may never exceed the filed Maximum Termination Liability.

A partial termination of specially constructed facilities will be provided, at the election of the customer. The amount of the Termination Charge associated with such partial termination is determined by multiplying the termination

* *New or Revised*

Continued

DATE ISSUED: July 31, 2002

EFFECTIVE DATE: September 18, 2002

Aloa J. Stevens
Director – State Government Affairs
Citizens Communications Company
4 Triad Center, Suite 200
Salt Lake City, Utah 84180

ACCESS SERVICE

14. Special Construction (Cont'd)14.2 Regulations (Cont'd)14.2.6 Liabilities and Charges for Special Construction (Cont'd)14.2.6.4 Types of Liabilities and Charges (Cont'd)(B) Maximum Termination Liability and Termination Charge (Cont'd)

charge which would result if all services using the specially constructed facilities were discontinued, at the time partial termination is elected, by the percentage of specially constructed facilities to be partially terminated. A tariff filing will be made following a partial termination to list remaining Maximum Termination Liability amounts and the number of specially constructed facilities the customer will remain liable for.

Example:

A customer with a filed Maximum Termination Liability of \$100,000 for 3600 specially constructed facilities requests a partial termination of 900 facilities. The Termination Charge for all facilities, at the time of election, is \$60,000. The partial termination charge, in this example, is $\$60,000 \times 900/3600$, or \$15,000.

(C) Annual Underutilization Liability and Underutilization Charge

Prior to the start of special construction, the Telephone Company and the customer will agree on (1) the quantity of facilities to be

** New or Revised**Continued*

DATE ISSUED: July 31, 2002

EFFECTIVE DATE: September 18, 2002

Aloa J. Stevens
Director – State Government Affairs
Citizens Communications Company
4 Triad Center, Suite 200
Salt Lake City, Utah 84180

ACCESS SERVICE

14. Special Construction (Cont'd)14.2 Regulations (Cont'd)14.2.6 Liabilities and Charges for Special Construction (Cont'd)14.2.6.4 Types of Liabilities and Charges (Cont'd)(C) Annual Underutilization Liability and Underutilization Charge (Cont'd)

provided, and (2) the length of the planning period during which the customer expects to place the facilities in service. The planning period is hereinafter referred to as the Initial Liability Period (ILP). The ILP is listed in the tariff with an effective and expiration date.

Underutilization occurs only if, at the expiration date of the ILP and annually thereafter, less than 70 percent of the specially constructed facilities are in service at filed tariff service rates.

An annual underutilization liability amount is filed on a per unit basis (e.g., per cable pair) for each case of special construction. This amount is equal to the annual per unit cost and includes depreciation, maintenance, administration, return, taxes, and any other costs identified in the supporting documentation provided at the time the special construction case is filed.

Upon the expiration of the ILP, the number of underutilized facilities, if any, are multiplied by the annual underutilization liability amount. This product is then multiplied by the number of years (including any fraction thereof) in the ILP to determine the underutilization charge.

* *New or Revised*

Continued

DATE ISSUED: July 31, 2002

EFFECTIVE DATE: September 18, 2002

Aloa J. Stevens
Director – State Government Affairs
Citizens Communications Company
4 Triad Center, Suite 200
Salt Lake City, Utah 84180

ACCESS SERVICE

14. Special Construction (Cont'd)14.2 Regulations (Cont'd)14.2.6 Liabilities and Charges for Special Construction (Cont'd)14.2.6.4 Types of Liabilities and Charges (Cont'd)(C) Annual Underutilization Liability and Underutilization Charge (Cont'd)

Annually thereafter, the number of underutilized facilities, if any, existing on the anniversary of the ILP expiration date will be multiplied by the annual underutilization liability amount to determine the underutilization charge for the preceding 12-month period.

Example:

A customer orders 100 services and the special construction of a 600 pair building riser cable is agreed to, based on the customer's 5-year facility requirements. The ILP, in this example, would be filed at 5 years. The annual underutilization liability is filed at \$2.00 per pair. If 400 pairs were in service at the end of the ILP, there would be an underutilization of 20 pairs; i.e., $420 (70\% \text{ of } 600) - 400 = 20$. The total underutilization charge for the first 5 years would be \$200.00, or \$2.00 per pair x 20 pairs x 5 years.

If 420 pairs are in service at the end of the sixth year, there is no underutilization; i.e., $420 - 420 = 0$.

* *New or Revised*

Continued

DATE ISSUED: July 31, 2002

EFFECTIVE DATE: September 18, 2002

Aloa J. Stevens
Director – State Government Affairs
Citizens Communications Company
4 Triad Center, Suite 200
Salt Lake City, Utah 84180

ACCESS SERVICE

14. Special Construction (Cont'd)14.2 Regulations (Cont'd)14.2.6 Liabilities and Charges for Special Construction (Cont'd)14.2.6.4 Types of Liabilities and Charges (Cont'd)(D) Recurring Monthly Charges(1) Charge for Route or Type Other Than Normal

When special construction is requested using a route or type of facility other than that which the Telephone Company would normally use, a recurring monthly charge, in addition to the monthly rates for service, is applicable. The charge is equal to the difference between the recurring costs of the specially constructed facilities and the recurring costs of the facilities the Telephone Company would have normally used.

(a) When an Optional Payment Charge as set forth in 14.2.6.4(A)(3) preceding has been elected, the recurring monthly charge will be reduced to include specially constructed facility operating expenses only.

(b) If the actual cost option as set forth in 14.2.6.3 preceding has been elected, the recurring charge will be adjusted to reflect the actual cost of the new construction when the costs

* *New or Revised*

Continued

DATE ISSUED: July 31, 2002

EFFECTIVE DATE: September 18, 2002

Aloa J. Stevens
Director – State Government Affairs
Citizens Communications Company
4 Triad Center, Suite 200
Salt Lake City, Utah 84180

ACCESS SERVICE

14. Special Construction (Cont'd)14.2 Regulations (Cont'd)14.2.6 Liabilities and Charges for Special Construction (Cont'd)14.2.6.4 Types of Liabilities and Charges (Cont'd)(D) Recurring Monthly Charges(1) Charge for Route or Type Other Than Normal (Cont'd)

(b) (Cont'd)

have been determined. This adjusted recurring charge is applicable from the start of service.

(E) Lease Charge

This charge applies when the Telephone Company leases equipment in order to meet service requirements. The amount of the charge is equal to the net added cost to the Telephone Company caused by the lease.

(F) Cancellation Charge

If a service order with which special construction is associated is cancelled prior to the start of service, a cancellation charge will apply. The charge will include all nonrecoverable costs incurred by the Telephone Company in association with the special construction up to and including the time of cancellation.

* *New or Revised*

Continued

DATE ISSUED: July 31, 2002

EFFECTIVE DATE: September 18, 2002

Aloa J. Stevens
Director – State Government Affairs
Citizens Communications Company
4 Triad Center, Suite 200
Salt Lake City, Utah 84180

ACCESS SERVICE

14. Special Construction (Cont'd)14.2 Regulations (Cont'd)14.2.7 Deferral of Start of Service

The Telephone Company may be requested to defer the start of service which will use specially constructed facilities subject to the provisions set forth in the service tariff under which service is being provided. Requests for special construction deferral must be in writing and are subject to the following regulations:

14.2.7.1 Construction Has Not Begun

If the Telephone Company has not incurred any installation costs before receiving a request for deferral, no charge applies.

14.2.7.2 Construction Has Begun

If the construction of facilities has begun before the Telephone Company receives a request for deferral, charges will vary as follows:

(A) All Services Are Deferred

When all services which will use specially constructed facilities are deferred, a charge based on the costs incurred by the Telephone Company during each month of the deferral will apply. Those costs include the recurring costs for that portion of the facilities already completed and any other costs associated with the deferral. The cost of any components of the nonrecurring charge which have been completed at the time of deferral will also apply.

* *New or Revised*

Continued

DATE ISSUED: July 31, 2002

EFFECTIVE DATE: September 18, 2002

Aloa J. Stevens
Director – State Government Affairs
Citizens Communications Company
4 Triad Center, Suite 200
Salt Lake City, Utah 84180

ACCESS SERVICE

14. Special Construction (Cont'd)14.2 Regulations (Cont'd)14.2.7 Deferral of Start of Service (Cont'd)14.2.7.2 Construction Has Begun (Cont'd)(B) Some Services Are Deferred

When some services which will use the specially constructed facilities are deferred, the construction case will be completed, and all special construction charges will apply.

14.2.7.3 Construction Complete

If the construction of facilities has been completed before the Telephone Company receives a request for deferral, all special construction charges will apply.

14.2.8 Definitions

Actual Cost - The term "Actual Cost" denotes all costs charged against a specific case of special construction, including any appropriate taxes.

Annual Underutilization Liability - The term "Annual Underutilization Liability" denotes a per unit amount which may be billed annually if fewer services are in use utilizing specially constructed facilities at filed tariff rates than were originally specially constructed.

Estimated Cost - The term "Estimated Cost" denotes all estimated costs that will be incurred in providing a specific case of special construction, including any appropriate taxes.

* *New or Revised*

Continued

DATE ISSUED: July 31, 2002

EFFECTIVE DATE: September 18, 2002

Aloa J. Stevens
Director – State Government Affairs
Citizens Communications Company
4 Triad Center, Suite 200
Salt Lake City, Utah 84180

ACCESS SERVICE

14. Special Construction (Cont'd)14.2 Regulations (Cont'd)14.2.8 Definitions (Cont'd)

Facilities - The term "Facilities" denotes any cable, poles, conduit, microwave or carrier equipment, wire center distribution frames, central office switching equipment, etc., utilized to provide intrastate services.

Initial Liability Period - The term "Initial Liability Period" denotes the initial planning period during which the customer expects to place specially constructed facilities in service.

Installed Cost - The term "Installed Cost" denotes the total investment (estimated or actual) required by the Telephone Company to provide specially constructed facilities.

Maximum Termination Liability - The term "Maximum Termination Liability" denotes the maximum amount which may be billed if all services using specially constructed facilities are terminated prior to the expiration of the Maximum Termination Liability Period.

Maximum Termination Liability Period - The term "Maximum Termination Liability Period" denotes the length of time for which a termination charge may apply if all services using specially constructed facilities are terminated.

Net Salvage - The term "Net Salvage" denotes the estimated scrap, sale, or trade-in value, less the estimated cost of removal. Cost of removal includes the costs of demolishing, tearing down, or otherwise disposing of the material and any other applicable costs. Since the cost of removal may exceed salvage value, net salvage may be negative.

* *New or Revised*

Continued

DATE ISSUED: July 31, 2002

EFFECTIVE DATE: September 18, 2002

Aloa J. Stevens
Director – State Government Affairs
Citizens Communications Company
4 Triad Center, Suite 200
Salt Lake City, Utah 84180

ACCESS SERVICE

14. Special Construction (Cont'd)14.2 Regulations (Cont'd)14.2.8 Definitions (Cont'd)

Nonrecoverable Cost - The term "Nonrecoverable Cost" denotes the cost of specially constructed facilities for which the Telephone Company has no foreseeable use should the service be terminated.

Normal Construction - The term "Normal Construction" denotes all facilities the Telephone Company would normally use to provide service in the absence of a requirement for special construction.

Normal Cost - The term "Normal Cost" denotes the estimated cost to provide services using normal construction.

Permanent Facilities - The term "Permanent Facilities" denotes facilities providing service for one month or more.

Recoverable Cost - The term "Recoverable Cost" denotes the cost of the specially constructed facilities for which the Telephone Company has a foreseeable reuse, either in place or elsewhere, should the service be terminated.

Termination Charge - The term "Termination Charge" denotes the portion of the Maximum Termination Liability that is applied as a nonrecurring charge when all services are discontinued prior to the expiration of the specified liability period.

* *New or Revised*

Continued

DATE ISSUED: July 31, 2002

EFFECTIVE DATE: September 18, 2002

Aloa J. Stevens
Director – State Government Affairs
Citizens Communications Company
4 Triad Center, Suite 200
Salt Lake City, Utah 84180

ACCESS SERVICE

14. Special Construction (Cont'd)14.3 Charges to Provide Permanent Facilities

This section contains special construction charges to provide permanent facilities. Charges are developed on an individual case basis and are filed following:

<u>Case No.</u>	<u>Telephone Co./ Customer Name</u>	<u>Description</u>	<u>Charge/ Liability</u>	<u>Effective Date</u>	<u>Expiration Date</u>
-----------------	-------------------------------------	--------------------	--------------------------	-----------------------	------------------------

* *New or Revised**Continued*

DATE ISSUED: July 31, 2002

EFFECTIVE DATE: September 18, 2002

Aloa J. Stevens
Director – State Government Affairs
Citizens Communications Company
4 Triad Center, Suite 200
Salt Lake City, Utah 84180

ACCESS SERVICE

15. Wire Center and Interconnection Information15.1 Serving Wire Center V and H Coordinate Information - Arizona

<u>LOCALITY</u>	<u>CLLI</u>	<u>WCV</u>	<u>WCH</u>	<u>CC</u>	<u>LATA</u>	<u>OT</u>	<u>NPA</u>	<u>NXX</u>
AGUA FRIA	BRDSAZMACG0	9101	6811	MNTN	666	ABDe jo	602	546
AGUA FRIA	AGFIAZSRDS0	9089	6788	5101	666	ABDe	602	561
AGUA FRIA	AGFIAZSRDS0	9089	6788	5101	666	ABDe	602	566
AGUA FRIA	PHNXAZMRCG0	9109	6795	5101	666	ABDE FGHI KLMU Vejo	602	583
AGUA FRIA	BRDSAZMACG0	9101	6811	5101	666	ABDe jo	602	584
AGUILA	AGULAZMA685	9071	6967	5101	666	BC	602	685
AJO	AJO AZMA387	9392	6838	5101	666	BC	602	387
ALPINE	ALPIAZXC339	8924	6249	2177	666	ABCG HPfh	602	339
ASH FORK	ASFKAZMA637	8774	6905	5101	666	BC	602	637
BAGDAD	BGDDAZMA633	8937	6997	5101	666	BC	602	633
BENSON	BNSNAZMADS0	9371	6352	5101	668	BDe	602	586
BISBEE	PLMNAZMA366	9486	6289	5101	668	BCe	602	366
BISBEE	BISBAZMA43A	9467	6248	5101	668	BC	602	432
BLACK CANYON	BLCNAZMA374	9006	6792	5101	666	BCe	602	374
BLACK MESA	BLMSAZXC677	8423	6608	2275	980	Cf	602	677
BLUE RIDGE	BLRGAZXC477	8854	6648	2171	666	A	602	477
BONITA	BONTAZXC828	9227	6329	2176	668	AC	602	828
BOUSE	BOUSAZXC851	9104	7115	2302	730	Ch	602	851
BOWIE	BOWIAZXC847	9259	6226	2176	668	A	602	847
BUCKEYE	BCKYAZMADSO	9170	6835	5101	666	BCe	602	386
BULLHEAD CITY	BLCYAZXC754	8862	7266	2172	666	ACGH	602	754
CAMERON	CMRNAZMA679	8624	6756	5101	666	BC	602	679
CAMP VERDE	CMVRAZMADSO	8888	6744	5101	666	BCe	602	567

* *New or Revised**Continued*

DATE ISSUED: July 31, 2002

EFFECTIVE DATE: September 18, 2002

Aloa J. Stevens
 Director – State Government Affairs
 Citizens Communications Company
 4 Triad Center, Suite 200
 Salt Lake City, Utah 84180

ACCESS SERVICE

15. Wire Center and Interconnection Information (Cont'd)15.1 Serving Wire Center V and H Coordinate Information - Arizona (Cont'd)

<u>LOCALITY</u>	<u>CLLI</u>	<u>WCV</u>	<u>WCH</u>	<u>CC</u>	<u>LATA</u>	<u>OT</u>	<u>NPA</u>	<u>NXX</u>
CASA GRANDE	CSGRAZMACGO	9241	6661	5101	666	BDe	602	421
CASA GRANDE	CSGRAZMACG0	9241	6661	5101	666	BDEF GHIK LMUV Yejo	602	426
CASA GRANDE	CSGRAZMACGO	9241	6662	5101	666	BDe	602	836
CASTLE ROCK	CSRKAZXC764	8983	7203	2172	666	ACGH	602	764
CAVE CREEK- CAREFREE	CVCKAZMACGO	9047	6740	5101	666	ABDj o	602	488
CHANDLER	CHNDAZWEDSO	9158	6721	5101	666	ABD	602	496
CHANDLER	CHNDAZMADS0	9154	6699	5101	666	BD	602	732
CHANDLER	CHNDAZWEDSO	9158	6721	5101	666	ABD	602	759
CHANDLER	CHNDAZPRRS1	9154	6699	5101	666	BD	602	786
CHANDLER	CHNDAZMADS0	9154	6699	5101	666	BDEF GHIK LMUV dejo	602	821
CHANDLER	CHNDAZSOCG0	9170	6696	5101	666	ABDe jo	602	895
CHANDLER	CHNDAZMADS0	9154	6699	5101	666	BDe	602	899
CHANDLER	CHNDAZWEDSO	9158	6721	MNTN	666	ABDd ejo	602	940
CHANDLER	CHNDAZWEDSO	9158	6721	5101	666	ABDd ejo	602	961

* *New or Revised**Continued*

DATE ISSUED: July 31, 2002

EFFECTIVE DATE: September 18, 2002

Aloa J. Stevens
 Director – State Government Affairs
 Citizens Communications Company
 4 Triad Center, Suite 200
 Salt Lake City, Utah 84180

ACCESS SERVICE

15. Wire Center and Interconnection Information (Cont'd)15.1 Serving Wire Center V and H Coordinate Information - Arizona (Cont'd)

<u>LOCALITY</u>	<u>CLLI</u>	<u>WCV</u>	<u>WCH</u>	<u>CC</u>	<u>LATA</u>	<u>OT</u>	<u>NPA</u>	<u>NXX</u>
CHANDLER	CHNDAZMADS0	9154	6699	5101	666	BD	602	963
CHINLE	CHNLAZXC674	8459	6446	2275	980	Cf	602	674
CHINO VALLEY	CHVYAZMARS1	8871	6879	5101	666	BCe	602	636
CIBOLA	CIBLAZXC857	9243	7221	2302	730	C	602	857
CIRCLE CITY	CRCYAZMA388	9075	6855	5101	666	BCe	602	388
CLIFTON	CFTNAZMA86A	9099	6238	5101	668	BCe	602	865
COLORADO CITY	CLCYAZXCDSO	8416	7074	2286	660	AC	602	875
COOLIDGE	CLDGAZMA723	9210	6625	5101	666	BCe	602	723
CORONADO	CRNDAZMADS0	9286	6494	5101	668	BDe	602	825
COTTONWOOD	CTWDAZMADS0	8856	6803	5101	666	BDe	602	634
COTTONWOOD	CTWDAZSORS1	8866	6791	5101	666	BDe	602	646
DEER VALLEY	DRVYAZNODSO	9085	6765	5101	666	ABDE FGHI KLMU Vdej o	602	434
DEER VALLEY	DRVYAZNODSO	9085	6765	5101	666	ABD	602	582
DEER VALLEY	DRVYAZNODSO	9085	6765	5101	666	ABD	602	780
DENNEHOTSO	DNHSAZXC658	8326	6534	2275	980	Cf	602	658
DILKON	DLKNAZXC657	8655	6538	2275	980	Cf	602	657
DOLAN SPRINGS	DLSPA ZXC767	8757	7234	2172	666	ACGH	602	767
DOUGLAS	DGLSAZMA36A	9467	6182	5101	668	BCEF GHIK LMUV Y	602	364
DUDLEYVILLE	DDVLAZNM MG0	9192	6478	5101	668	BCEF GHIK LMUV e	602	357

* New or Revised

Continued

DATE ISSUED: July 31, 2002

EFFECTIVE DATE: September 18, 2002

Aloa J. Stevens
Director – State Government Affairs
Citizens Communications Company
4 Triad Center, Suite 200
Salt Lake City, Utah 84180

ACCESS SERVICE

15. Wire Center and Interconnection Information (Cont'd)15.1 Serving Wire Center V and H Coordinate Information - Arizona (Cont'd)

<u>LOCALITY</u>	<u>CLLI</u>	<u>WCV</u>	<u>WCH</u>	<u>CC</u>	<u>LATA</u>	<u>OT</u>	<u>NPA</u>	<u>NXX</u>
DUNCAN	DNCNAZNMGM0	9159	6179	5101	668	BCEF GHIK LMUV	602	359
EHRENBERG	EHRNAZXC923	9193	7193	2302	730	C	602	923
ELFRIDA	ELFRAZMA642	9402	6227	5101	668	BC	602	642
ELOYELOYAZMA466	9260 6619	5101	666	BCe	602	466		
FLAGSTAFF	FLGSAZMADS0	8746	6759	5101	666	BCEF GHIK LMUV Ye	602	523
FLAGSTAFF	FLGSAZSORS1	8771	6761	5101	666	BCe	602	525
FLAGSTAFF	FLGSAZEACG0	8740	6751	5101	666	ABDe jo	602	526
FLAGSTAFF	FLGSAZEACG0	8740	6751	5101	666	ABDe jo	602	527
FLAGSTAFF	FLGSAZMADS0	8746	6759	5101	666	BC	602	773
FLAGSTAFF	FLGSAZMADS0	8746	6759	5101	666	BC	602	774
FLAGSTAFF	FLGSAZMADS0	8746	6759	5101	666	BC	602	779
FLAGSTAFF	FLGSAZMAXXX	8746	6759	5101	666	P	602	PAH
FLAGSTAFF	FLGSAZMAXXX	8746	6759	5101	666	Q	602	VDH
FLORENCE	FLRNAZMA868	9193	6604	5101	666	BCe	602	868
FORT DEFIANCE	FTDFAZXC729	8523	6344	2275	980	Cfjh602 729		
FORT MC DOWELL	FTMDAZNORS1	9104	6679	5101	666	BDe	602	471
FORT MC DOWELL	FTMDAZMACG0	9085	6694	5101	666	BDej o	602	837
FREDONIA	FRDNAZMA64A	8387	6998	5101	660	A	602	643
GANADO	GANDAZXC755	8550	6421	2275	980	Cf	602	755
GILA BEND	GLBNAZMA683	9265	6838	5101	666	BC	602	683
GLEN CANYON CITY, UT	PAGEAZMA64A	8375	6811	5101	666	BC	801	675

* New or Revised

Continued

DATE ISSUED: July 31, 2002

EFFECTIVE DATE: September 18, 2002

Aloa J. Stevens
Director – State Government Affairs
Citizens Communications Company
4 Triad Center, Suite 200
Salt Lake City, Utah 84180

ACCESS SERVICE

15. Wire Center and Interconnection Information (Cont'd)15.1 Serving Wire Center V and H Coordinate Information - Arizona (Cont'd)

<u>LOCALITY</u>	<u>CLLI</u>	<u>WCV</u>	<u>WCH</u>	<u>CC</u>	<u>LATA</u>	<u>OT</u>	<u>NPA</u>	<u>NXX</u>
GLENDALÉ	GLDLAZMACG0	9118	6772	5101	666	ABD	602	435
GLENDALÉ	PHNXAZGRCG0	9098	6767	5101	666	ABD	602	439
GLENDALÉ	PHNXAZPRCG0	9108	6782	5101	666	ABD	602	486
GLENDALÉ	PHNXAZNWCG0	9118	6760	5101	666	ABDE FGHT KLMU Vdej o	602	589
GLENDALÉ	GLDLAZMACG0	9118	6772	5101	666	ABDE FGHI KLMU Vdej o	602	842
GLENDALÉ	PHNXAZGRCG0	9098	6767	5101	666	ABD	602	843
GLENDALÉ	PHNXAZMYCG0	9128	6773	5101	666	ABDE FGHI KLMU Vdej o	602	846
GLENDALÉ	PHNXAZMYCG0	9128	6773	5101	666	ABD	602	848
GLENDALÉ	PHNXAZBWCG0	9128	6786	5101	666	ABDd ejo	602	872
GLENDALÉ	PHNXAZMRCG0	9109	6795	5101	666	ABD	602	876
GLENDALÉ	PHNXAZBWCG0	9128	6786	5101	666	ABDd ejo	602	877

* *New or Revised**Continued*

DATE ISSUED: July 31, 2002

EFFECTIVE DATE: September 18, 2002

Aloa J. Stevens
 Director – State Government Affairs
 Citizens Communications Company
 4 Triad Center, Suite 200
 Salt Lake City, Utah 84180

ACCESS SERVICE

15. Wire Center and Interconnection Information (Cont'd)15.1 Serving Wire Center V and H Coordinate Information - Arizona (Cont'd)

<u>LOCALITY</u>	<u>CLLI</u>	<u>WCV</u>	<u>WCH</u>	<u>CC</u>	<u>LATA</u>	<u>OT</u>	<u>NPA</u>	<u>NXX</u>
GLENDALÉ	PHNXAZPRCG0	9108	6782	5101	666	ABDE FGHI KLMU Vejo	602	878
GLENDALÉ	GLDLAZMACG0	9118	6772	5101	666	ABD	602	930
GLENDALÉ	GLDLAZMACG0	9118	6772	5101	666	ABD	602	931
GLENDALÉ	PHNXAZMRCG0	9109	6795	5101	666	ABD	602	933
GLENDALÉ	GLDLAZMACG0	9118	6772	5101	666	ABD	602	934
GLENDALÉ	GLDLAZMACG0	9118	6772	5101	666	ABD	602	937
GLENDALÉ	PHNXAZGRCG0	9098	6767	5101	666	ABD	602	938
GLENDALÉ	GLDLAZMACG0	9118	6772	5101	666	ABD	602	939
GLENDALÉ	PHNXAZMRCG0	9109	6795	5101	666	ABD	602	972
GLENDALÉ	PHNXAZMRCG0	9109	6795	5101	666	ABD	602	974
GLENDALÉ	BRDSAZMACG0	9101	6811	5101	666	ABDe jo	602	975
GLENDALÉ	PHNXAZMRCG0	9109	6795	5101	666	ABDE FGHI KLMU Vejo	602	977
GLENDALÉ	PHNXAZGRCG0	9098	6767	5101	666	ABDE FGHI KLMU Vdej o	602	978
GLENDALÉ	PHNXAZPRCG0	9108	6782	5101	666	ABD	602	979

* New or Revised

Continued

DATE ISSUED: July 31, 2002

EFFECTIVE DATE: September 18, 2002

Aloa J. Stevens
 Director – State Government Affairs
 Citizens Communications Company
 4 Triad Center, Suite 200
 Salt Lake City, Utah 84180

ACCESS SERVICE

15. Wire Center and Interconnection Information (Cont'd)15.1 Serving Wire Center V and H Coordinate Information - Arizona (Cont'd)

<u>LOCALITY</u>	<u>CLLI</u>	<u>WCV</u>	<u>WCH</u>	<u>CC</u>	<u>LATA</u>	<u>OT</u>	<u>NPA</u>	<u>NXX</u>
GLOBE	GLOBAZMA425	9091	6516	5101	668	BCEF GHIK LMUV e	602	425
GOLDEN VALLEY	GLVYAZXC565	8832	7199	2172	666	ACGH	602	565
GRAND CANYON	GRCNAZMA638	8584	6886	5101	666	BCe	602	638
GREASEWOOD	GSWDAZXC654	8604	6465	2275	980	Cf	602	654
GREEN HAVEN	MRCNAZXE353	8361	6833	2171	666	A	602	353
GREEN VALLEY	GNVYAZMADSO	9421	6473	5101	668	BDe	602	625
GREEN VALLEY	GNVYAZMADSO	9421	6473	5101	668	BDe	602	648
GREER	GRERAZXC735	8902	6312	2177	666	ABCG Hfj	602	735
HARQUAHALA VALLEY	HRVYAZXC372	9176	6940	2171	666	A	602	372
HAWLEY LAKE	HLLKAZXC335	8924	6364	2177	666	ABCf hj	602	335
HAYDEN	HYDNAZMA356	9174	6495	5101	668	BCe	602	356
HAYDEN	KRNYAZMA363	9157	6520	5101	668	BCe	602	363
HEBER	HEBRAZXCDS0	8867	6537	2177	666	ABCG HPfh j	602	535
HIGLEY	HGLYAZQCDSO	9161	6659	5101	666	BDde	602	987
HIGLEY	HGLYAZMADSO	9148	6671	5101	666	BDde	602	988
HOLBROOK	HLBKAZXC524	8748	6484	2177	666	ABCG HNPF hjo	602	524

* *New or Revised**Continued*

DATE ISSUED: July 31, 2002

EFFECTIVE DATE: September 18, 2002

Aloa J. Stevens
 Director – State Government Affairs
 Citizens Communications Company
 4 Triad Center, Suite 200
 Salt Lake City, Utah 84180

ACCESS SERVICE

15. Wire Center and Interconnection Information (Cont'd)15.1 Serving Wire Center V and H Coordinate Information - Arizona (Cont'd)

<u>LOCALITY</u>	<u>CLLI</u>	<u>WCV</u>	<u>WCH</u>	<u>CC</u>	<u>LATA</u>	<u>OT</u>	<u>NPA</u>	<u>NXX</u>
HUMBOLDT	HMBLAZMA632	8917	6828	5101	666	BCe	602	632
HYDER	HYDRAZXC454	9274	6955	2171	666	A	602	454
JOSEPH CITY	JSCYAZMA288	8743	6518	5101	666	BC	602	288
KAIBITO	KABTAZXC673	8428	6730	2275	980	Cf	602	673
KAYENTA	KYNTAZXC697	8368	6597	2275	980	Cfh	602	697
KEAMS CANYON	KMCNAZXC738	8556	6538	2175	666	C	602	738
KINGMAN	KGMNAZXC01T	8837	7179	2172	666	ACGH e	602	753
KINGMAN	KGMNAZXE757	8822	7173	2172	666	ACGH e	602	757
KYKOTSMOVI VILLAGE	KIVGAZXC734	8562	6615	2175	666	CGH	602	734
LAKE HAVASU CITY	LHCYAZXCDSO	9004	7202	2172	666	ACGH e	602	453
LAKE HAVASU CITY	LHCYAZXCDSO	9004	7202	2172	666	ACGH e	602	855
LAKESIDE	PNTPAZXBR51	8896	6413	2177	666	ABCG HPfh j	602	368
LE CHEE	LCHEAZXC698	8388	6805	2275	980	Cf	602	698
LEUPP	LEPPAZXC686	8699	6652	2275	980	Cf	602	686
LITCHFIELD PARK	LTPKAZMACGO	9135	6801	5101	666	BD	602	393
LITCHFIELD PARK	PHNXAZMYCG0	9128	6773	5101	666	ABDE FGHI KLMU Vdej o	602	849

* New or Revised

Continued

DATE ISSUED: July 31, 2002

EFFECTIVE DATE: September 18, 2002

Aloa J. Stevens
Director – State Government Affairs
Citizens Communications Company
4 Triad Center, Suite 200
Salt Lake City, Utah 84180

ACCESS SERVICE

15. Wire Center and Interconnection Information (Cont'd)15.1 Serving Wire Center V and H Coordinate Information - Arizona (Cont'd)

<u>LOCALITY</u>	<u>CLLI</u>	<u>WCV</u>	<u>WCH</u>	<u>CC</u>	<u>LATA</u>	<u>OT</u>	<u>NPA</u>	<u>NXX</u>
LITCHFIELD PARK	LTPKAZMACG0	9135	6801	5101	666	BDFG HIKL MUVd ejo	602	856
LITCHFIELD PARK	PHNXAZMYCG0	9128	6773	5101	666	ABD	602	873
LITCHFIELD PARK	GDYRAZCWMG0	9147	6798	5101	666	BCde	602	925
LITCHFIELD PARK	GDYRAZCWMG0	9147	6798	5101	666	BCde	602	932
LITCHFIELD PARK	LTPKAZMACG0	9135	6801	5101	666	BDde	602	935
LITCHFIELD PARK	TLSNAZMACG0	9140	6780	5101	666	ABDd ejo	602	936
LITTLEFIELD	LLFDAZXF347	8488	7231	2356	660	Cjo	602	347
LUKACHUKAI	LKCHAZXC787	8391	6409	2275	980	Cf	602	787
MANY FARMS	MNFRAZXC781	8419	6469	2275	980	Cf	602	781
MARANA	MARNAZMARS1	9307	6544	5101	668	BCde	602	682
MARBLE CANYON	MRCNAZXC355	8403	6838	2171	666	A	602	355
MARICOPA	MRCPAZMA568	9215	6725	5101	666	BC	602	568
MCNARY	MCNRAZXCRS1	8910	6386	2177	666	ABCG HPfh j	602	334
MEADVIEW	MDVWAZXC564	8665	7219	2172	666	ACGH	602	564
MESA	MESAAZMACG0	9130	6703	5101	666	ABD	602	461
MESA	MESAAZMACG0	9130	6703	5101	666	ABD	602	464
MESA	MESAAZGIDSO	9140	6693	5101	666	ABD	602	497
MESA	MESAAZMACG0	9130	6703	5101	666	ABDb dejo	602	827

* *New or Revised**Continued*

DATE ISSUED: July 31, 2002

EFFECTIVE DATE: September 18, 2002

Aloa J. Stevens
 Director – State Government Affairs
 Citizens Communications Company
 4 Triad Center, Suite 200
 Salt Lake City, Utah 84180

ACCESS SERVICE

15. Wire Center and Interconnection Information (Cont'd)15.1 Serving Wire Center V and H Coordinate Information - Arizona (Cont'd)

<u>LOCALITY</u>	<u>CLLI</u>	<u>WCV</u>	<u>WCH</u>	<u>CC</u>	<u>LATA</u>	<u>OT</u>	<u>NPA</u>	<u>NXX</u>
MESA	SPRSAZWECG0	9125	6685	5101	666	ABDE FGHI KLMU Vdej o	602	830
MESA	SPRSAZWECG0	9125	6685	5101	666	ABD	602	832
MESA	MESAAZMACG0	9130	6703	5101	666	ABDd ejo	602	833
MESA	MESAAZMACG0	9130	6703	5101	666	ABD	602	834
MESA	MESAAZMACG0	9130	6703	5101	666	ABD	602	835
MESA	MESAAZMACG0	9130	6703	5101	666	ABD	602	844
MESA	MESAAZMACG0	9130	6703	5101	666	ABD	602	890
MESA	MESAAZGIDSO	9140	6693	5101	666	ABDd e	602	892
MESA	MESAAZMACG0	9130	6703	5101	666	ABD	602	898
MESA	MESAAZGIDSO	9140	6693	5101	666	ABD	602	926
MESA	MESAAZMACG0	9130	6703	5101	666	ABD	602	962
MESA	MESAAZMACG0	9130	6703	5101	666	ABD	602	964
MESA	MESAAZMACG0	9130	6703	5101	666	ABD	602	969
MIAMI	MIAMAZMA473	9094	6531	5101	668	BCe	602	473
MOHAVE VALLEY	MHVYAZXC768	8913	7264	2172	666	ACGH	602	768
MORMON LAKE	MMLKAZXC354	8798	6714	2171	666	A	602	354
MUNDS PARK	MSPKAZMADSO	8800	6747	5101	666	BD	602	286
NEW RIVER	NWRVAZMA465	9034	6777	5101	666	BCde	602	465
NOGALES	NGLSAZMWCg1	9522	6440	5101	668	ABDd ejo	602	281

* *New or Revised**Continued*

DATE ISSUED: July 31, 2002

EFFECTIVE DATE: September 18, 2002

Aloa J. Stevens
 Director – State Government Affairs
 Citizens Communications Company
 4 Triad Center, Suite 200
 Salt Lake City, Utah 84180

ACCESS SERVICE

15. Wire Center and Interconnection Information (Cont'd)15.1 Serving Wire Center V and H Coordinate Information - Arizona (Cont'd)

<u>LOCALITY</u>	<u>CLLI</u>	<u>WCV</u>	<u>WCH</u>	<u>CC</u>	<u>LATA</u>	<u>OT</u>	<u>NPA</u>	<u>NXX</u>
NOGALES	NGLSAZMA28A	9532	6436	5101	668	BCEF GHIK LMUV Yde	602	287
NORTH PHOENIX	PHNXAZGRCG0	9098	6767	5101	666	ABD	602	375
NORTH PHOENIX	PHNXAZSYCG0	9108	6754	5101	666	ABD	602	395
NORTH PHOENIX	PHNXAZCACG0	9099	6744	5101	666	ABDE FGHI KLMU Vdej o	602	482
NORTH PHOENIX	DRVYAZNODSO	9085	6765	5101	666	ABD	602	492
NORTH PHOENIX	PHNXAZCACG0	9099	6744	5101	666	ABD	602	493
NORTH PHOENIX	PHNXAZCACG0	9099	6744	5101	666	ABD	602	494
NORTH PHOENIX	PHNXAZCACG0	9099	6744	5101	666	ABD	602	569
NORTH PHOENIX	DRVYAZNODSO	9085	6765	5101	666	ABD	602	581
NORTH PHOENIX	PHNXAZGRCG0	9098	6767	5101	666	ABD	602	588
NORTH PHOENIX	PHNXAZSYCG0	9108	6754	5101	666	ABD	602	678
NORTH PHOENIX	PHNXAZCACG0	9099	6744	5101	666	ABD	602	788
NORTH PHOENIX	PHNXAZGRCG0	9098	6767	5101	666	ABD	602	789
NORTH PHOENIX	PHNXAZSYCG0	9108	6754	5101	666	ABDE FGHI KLMU Vdej o	602	861
NORTH PHOENIX	PHNXAZGRCG0	9098	6767	5101	666	ABD	602	862
NORTH PHOENIX	PHNXAZGRCG0	9098	6767	5101	666	ABD	602	863

* *New or Revised**Continued*

DATE ISSUED: July 31, 2002

EFFECTIVE DATE: September 18, 2002

Aloa J. Stevens
 Director – State Government Affairs
 Citizens Communications Company
 4 Triad Center, Suite 200
 Salt Lake City, Utah 84180

ACCESS SERVICE

15. Wire Center and Interconnection Information (Cont'd)15.1 Serving Wire Center V and H Coordinate Information - Arizona (Cont'd)

<u>LOCALITY</u>	<u>CLLI</u>	<u>WCV</u>	<u>WCH</u>	<u>CC</u>	<u>LATA</u>	<u>OT</u>	<u>NPA</u>	<u>NXX</u>
NORTH PHOENIX	PHNXAZNWCG0	9118	6760	5101	666	ABDE FGHI KLMU Vdej o	602	864
NORTH PHOENIX	PHNXAZGRCG0	9098	6767	5101	666	ABD	602	866
NORTH PHOENIX	PHNXAZCACG0	9099	6744	5101	666	ABD	602	867
NORTH PHOENIX	DRVYAZNODSO	9085	6765	5101	666	ABD	602	869
NORTH PHOENIX	DRVYAZNODSO	9085	6765	5101	666	ABDE FGHI KLMU Vdej o	602	879
NORTH PHOENIX	PHNXAZGRCG0	9098	6767	5101	666	ABDE FGHI KLMU Vdej o	602	942
NORTH PHOENIX	PHNXAZSYCG0	9108	6754	5101	666	ABD	602	943
NORTH PHOENIX	PHNXAZSYCG0	9108	6754	5101	666	ABD	602	944
NORTH PHOENIX	PHNXAZCACG0	9099	6744	5101	666	ABD	602	953
NORTH PHOENIX	PHNXAZCACG0	9099	6744	5101	666	ABD	602	971
NORTH PHOENIX	PHNXAZCACG0	9099	6744	5101	666	ABD	602	992
NORTH PHOENIX	PHNXAZGRCG0	9098	6767	5101	666	ABD	602	993
NORTH PHOENIX	PHNXAZNWCG0	9118	6760	5101	666	ABD	602	995
NORTH PHOENIX	PHNXAZCACG0	9099	6744	5101	666	ABD	602	996
NORTH PHOENIX	PHNXAZSYCG0	9108	6754	5101	666	ABD	602	997
PAGE	PAGEAZMA64A		8375	6811	5101	666 BC	602	645

* *New or Revised**Continued*

DATE ISSUED: July 31, 2002

EFFECTIVE DATE: September 18, 2002

Aloa J. Stevens
 Director – State Government Affairs
 Citizens Communications Company
 4 Triad Center, Suite 200
 Salt Lake City, Utah 84180

ACCESS SERVICE

15. Wire Center and Interconnection Information (Cont'd)15.1 Serving Wire Center V and H Coordinate Information - Arizona (Cont'd)

<u>LOCALITY</u>	<u>CLLI</u>	<u>WCV</u>	<u>WCH</u>	<u>CC</u>	<u>LATA</u>	<u>OT</u>	<u>NPA</u>	<u>NXX</u>
PARADISE VALLEY	PRVYAZPPDSO	9072	6727	5101	666	BDej o	602	563
PARADISE VALLEY	PRVYAZPPDSO	9072	6727	5101	666	BDej o	602	585
PARKER	PRKRAZXC66A	9068	7175	2302	730	ACh	602	669
PARKER DAM	PRDMAZXC667	9032	7153	2302	730	Ch	602	667
PATAGONIA	PTGNAZMA394	9480	6412	5101	668	BC	602	394
PATAGONIA	PTGNAZEL455	9494	6377	5101	668	BC	602	455
PAYSON	PYSNAZMADSO	8938	6655	5101	666	BDEF GHIK LMUV e	602	474
PAYSON	PINEAZMA476	8910	6685	5101	666	BCe	602	476
PAYSON	TNCKAZMA478	8907	6618	5101	666	BC	602	478
PEACH SPRINGS	PCSPAZXC769	8744	7084	2172	666	ACGH	602	769
PEARCE	PERCAZXC826	9364	6264	2176	668	Ae	602	826
PHOENIX	PHNXAZEACG0	9130	6738	5101	666	ABD	602	220
PHOENIX	PHNXAZNOCG1	9123	6749	5101	666	ABD	602	221
PHOENIX	PHNXAZNOCG1	9123	6749	5101	666	ABD	602	222
PHOENIX	PHNXAZMACG1	9133	6748	5101	666	ABD	602	223
PHOENIX	PHNXAZNECG0	9121	6737	5101	666	ABD	602	224
PHOENIX	PHNXAZEACG0	9130	6738	5101	666	ABDd ejo	602	225
PHOENIX	PHNXAZMACG1	9133	6748	5101	666	ABDd ejo	602	226
PHOENIX	PHNXAZMACG0	9133	6748	5101	666	ABD	602	227
PHOENIX	PHNXAZCRCM1	9130	6738	5101	666	ABD	602	228

* New or Revised

Continued

DATE ISSUED: July 31, 2002

EFFECTIVE DATE: September 18, 2002

Aloa J. Stevens
Director – State Government Affairs
Citizens Communications Company
4 Triad Center, Suite 200
Salt Lake City, Utah 84180

ACCESS SERVICE

15. Wire Center and Interconnection Information (Cont'd)15.1 Serving Wire Center V and H Coordinate Information - Arizona (Cont'd)

<u>LOCALITY</u>	<u>CLLI</u>	<u>WCV</u>	<u>WCH</u>	<u>CC</u>	<u>LATA</u>	<u>OT</u>	<u>NPA</u>	<u>NXX</u>
PHOENIX	PHNXAZMACG0	9133	6748	5101	666	ABD	602	229
PHOENIX	PHNXAZNOCG0	9123	6749	5101	666	ABDj o	602	230
PHOENIX	PHNXAZEACG0	9130	6738	5101	666	ABDE FGHI KLMU Vdej o	602	231
PHOENIX	PHNXAZSOCG0	9145	6745	5101	666	ABDE FGHI KLMU Vdej o	602	232
PHOENIX	PHNXAZWECG0	9135	6759	5101	666	ABD	602	233
PHOENIX	PHNXAZNOCG1	9123	6749	5101	666	ABD	602	234
PHOENIX	PHNXAZNOCG0	9123	6749	5101	666	ABDj o	602	235
PHOENIX	PHNXAZEACG0	9130	6738	5101	666	ABD	602	236
PHOENIX	PHNXAZLVDSO	9155	6760	5101	666	BDe	602	237
PHOENIX	PHNXAZMACG1	9133	6748	5101	666	ABDe FGHI KLMU VYde jo	602	238
PHOENIX	PHNXAZMACG0	9133	6748	5101	666	ABD	602	239
PHOENIX	PHNXAZNOCG1	9123	6749	5101	666	ABD	602	240
PHOENIX	PHNXAZNOCG1	9123	6749	5101	666	ABD	602	241

* *New or Revised**Continued*

DATE ISSUED: July 31, 2002

EFFECTIVE DATE: September 18, 2002

Aloa J. Stevens
 Director – State Government Affairs
 Citizens Communications Company
 4 Triad Center, Suite 200
 Salt Lake City, Utah 84180

ACCESS SERVICE

15. Wire Center and Interconnection Information (Cont'd)15.1 Serving Wire Center V and H Coordinate Information - Arizona (Cont'd)

<u>LOCALITY</u>	<u>CLLI</u>	<u>WCV</u>	<u>WCH</u>	<u>CC</u>	<u>LATA</u>	<u>OT</u>	<u>NPA</u>	<u>NXX</u>
PHOENIX	PHNXAZNWCG0	9118	6760	5101	666	ABD	602	242
PHOENIX	PHNXAZSOCG0	9145	6745	5101	666	ABD	602	243
PHOENIX	PHNXAZEACG0	9130	6738	5101	666	ABD	602	244
PHOENIX	PHNXAZMYCG0	9128	6773	5101	666	ABD	602	245
PHOENIX	PHNXAZNWCG0	9118	6760	5101	666	ABD	602	246
PHOENIX	PHNXAZMYCG0	9128	6773	5101	666	ABDE FGHI KLMU Vdej o	602	247
PHOENIX	PHNXAZNOCG0	9123	6749	5101	666	ABDj o	602	248
PHOENIX	PHNXAZNWCG0	9118	6760	5101	666	ABDE FGHI KLMU Vdej o	602	249
PHOENIX	PHNXAZMACG1	9133	6748	5101	666	ABDd ejo	602	250
PHOENIX	PHNXAZMACG0	9133	6748	5101	666	ABD	602	251
PHOENIX	PHNXAZMACG0	9133	6748	5101	666	ABD	602	252
PHOENIX	PHNXAZMACG0	9133	6748	5101	666	ABD	602	253
PHOENIX	PHNXAZMACG0	9133	6748	5101	666	ABD	602	254
PHOENIX	PHNXAZMACG1	9133	6748	5101	666	ABD	602	255
PHOENIX	PHNXAZMACG0	9133	6748	5101	666	ABD	602	256
PHOENIX	PHNXAZMACG0	9133	6748	5101	666	ABD	602	257
PHOENIX	PHNXAZMACG1	9133	6748	5101	666	ABD	602	258
PHOENIX	PHNXAZMACG1	9133	6748	5101	666	ABD	602	259

* *New or Revised**Continued*

DATE ISSUED: July 31, 2002

EFFECTIVE DATE: September 18, 2002

Aloa J. Stevens
 Director – State Government Affairs
 Citizens Communications Company
 4 Triad Center, Suite 200
 Salt Lake City, Utah 84180

ACCESS SERVICE

15. Wire Center and Interconnection Information (Cont'd)15.1 Serving Wire Center V and H Coordinate Information - Arizona (Cont'd)

<u>LOCALITY</u>	<u>CLLI</u>	<u>WCV</u>	<u>WCH</u>	<u>CC</u>	<u>LATA</u>	<u>OT</u>	<u>NPA</u>	<u>NXX</u>
PHOENIX	PHNXAZNOCG0	9123	6749	5101	666	ABDj o	602	260
PHOENIX	PHNXAZMACG0	9133	6748	5101	666	ABD	602	261
PHOENIX	PHNXAZMACG0	9133	6748	5101	666	ABD	602	262
PHOENIX	PHNXAZNOCG0	9123	6749	5101	666	ABDj o	602	263
PHOENIX	PHNXAZNOCG1	9123	6749	5101	666	ABD	602	264
PHOENIX	PHNXAZNOCG0	9123	6749	5101	666	ABDj o	602	265
PHOENIX	PHNXAZNOCG0	9123	6749	5101	666	ABDj o	602	266
PHOENIX	PHNXAZEACG0	9130	6738	5101	666	ABD	602	267
PHOENIX	PHNXAZSOCG0	9145	6745	5101	666	ABD	602	268
PHOENIX	PHNXAZWECG0	9135	6759	5101	666	ABD	602	269
PHOENIX	PHNXAZMACG0	9133	6748	5101	666	ABD	602	270
PHOENIX	PHNXAZMACG1	9133	6748	5101	666	ABD	602	271
PHOENIX	PHNXAZWECG0	9135	6759	5101	666	ABDE FGHI KLMU Vdej o	602	272
PHOENIX	PHNXAZEACG0	9130	6738	5101	666	ABD	602	273
PHOENIX	PHNXAZNOCG1	9123	6749	5101	666	ABD	602	274
PHOENIX	PHNXAZEACG0	9130	6738	5101	666	ABD	602	275
PHOENIX	PHNXAZSOCG0	9145	6745	5101	666	ABD	602	276
PHOENIX	PHNXAZNOCG1	9123	6749	5101	666	ABD	602	277
PHOENIX	PHNXAZWECG0	9135	6759	5101	666	ABD	602	278

* *New or Revised**Continued*

DATE ISSUED: July 31, 2002

EFFECTIVE DATE: September 18, 2002

Aloa J. Stevens
 Director – State Government Affairs
 Citizens Communications Company
 4 Triad Center, Suite 200
 Salt Lake City, Utah 84180

ACCESS SERVICE

15. Wire Center and Interconnection Information (Cont'd)15.1 Serving Wire Center V and H Coordinate Information - Arizona (Cont'd)

<u>LOCALITY</u>	<u>CLLI</u>	<u>WCV</u>	<u>WCH</u>	<u>CC</u>	<u>LATA</u>	<u>OT</u>	<u>NPA</u>	<u>NXX</u>
PHOENIX	PHNXAZNOCG1	9123	6749	5101	666	ABD	602	279
PHOENIX	PHNXAZNOCG0	9123	6749	5101	666	ABD	602	280
PHOENIX	PHNXAZNOCG1	9123	6749	5101	666	ABDE FGHI KLMU Vdej o	602	285
PHOENIX	PHNXAZNOCG0	9123	6749	5101	666	ABD	602	251
PHOENIX	PHNXAZWECG0	9135	6759	5101	666	ABD	602	252
PHOENIX	PHNXAZCRCM1	9130	6738	5101	666	ABD	602	370
PHOENIX	PHNXAZSYCGO	9108	6754	5101	666	ABD	602	371
PHOENIX	PHNXAZEACGO	9130	6738	5101	666	ABD	602	376
PHOENIX	PHNXAZEACGO	9130	6738	5101	666	ABDd ejo	602	377
PHOENIX	PHNXAZMADS1	9133	6748	5101	666	Df	602	379
PHOENIX	PHNXAZNECGO	9121	6737	5101	666	ABD	602	381
PHOENIX	PHNXAZEACGO	9130	6738	5101	666	ABD	602	389
PHOENIX	PHNXAZEACGO	9130	6738	5101	666	ABD	602	390
PHOENIX	PHNXAZEACGO	9130	6738	5101	666	ABDd ejo	602	392
PHOENIX	PHNXAZEACGO	9130	6738	5101	666	ABD	602	397
PHOENIX	PHNXAZGWDS0	9098	6767	5101	666	ef	602	420
PHOENIX	PHNXAZSECGO	9142	6731	5101	666	ABDE FGHI KLMU Vdej o	602	431
PHOENIX	PHNXAZNWCG0	9118	6760	5101	666	ABD	602	433

* *New or Revised**Continued*

DATE ISSUED: July 31, 2002

EFFECTIVE DATE: September 18, 2002

Aloa J. Stevens
 Director – State Government Affairs
 Citizens Communications Company
 4 Triad Center, Suite 200
 Salt Lake City, Utah 84180

ACCESS SERVICE

15. Wire Center and Interconnection Information (Cont'd)15.1 Serving Wire Center V and H Coordinate Information - Arizona (Cont'd)

<u>LOCALITY</u>	<u>CLLI</u>	<u>WCV</u>	<u>WCH</u>	<u>CC</u>	<u>LATA</u>	<u>OT</u>	<u>NPA</u>	<u>NXX</u>
PHOENIX	PHNXAZSECG0	9142	6731	5101	666	ABD	602	437
PHOENIX	PHNXAZSECG0	9142	6731	5101	666	ABD	602	438
PHOENIX	PHNXAZ81DS0	9121	6737	5101	666	ABD	602	460
PHOENIX	PHNXAZNECG0	9121	6737	5101	666	ABD	602	468
PHOENIX	PHNXAZWECGO	9135	6759	5101	666	ABD	602	484
PHOENIX	PHNXAZMACGO	9133	6748	5101	666	ABDd ejo	602	495
PHOENIX	PHNXAZMACG0	9133	6748	5101	666	ABD	602	498
PHOENIX	PHNXAZGRCG0	9098	6767	MNTN	666	ABD	602	543
PHOENIX	PHNXAZMA1XD	9133	6748	5101	666	f	602	549
PHOENIX	PHNXAZNECG0	9121	6737	5101	666	ABD	602	551
PHOENIX	PHNXAZMA5CD	9133	6748	5101	666	J	602	555
PHOENIX	PHNXAZNOCG1	9123	6749	5101	666	ABD	602	631
PHOENIX	PHNXAZNWCG0	9118	6760	5101	666	ABD	602	841
PHOENIX	PHNXAZMAO4T	9133	6748	5101	666	ABD	602	850
PHOENIX	PHNXAZSYCG0	9108	6754	5101	666	ABDE FGHI KLMU Vdej o	602	870
PHOENIX	PHNXAZNOCG1	9123	6749	5101	666	ABDd ejo	602	950
PHOENIX	PHNXAZNECG0	9121	6737	5101	666	ABD	602	954
PHOENIX	PHNXAZNECG0	9121	6737	5101	666	ABD	602	955
PHOENIX	PHNXAZNECG0	9121	6737	5101	666	ABD	602	956
PHOENIX	PHNXAZNECG0	9121	6737	5101	666	ABDE FGHI KLMU Vdej o	602	957

* New or Revised

Continued

DATE ISSUED: July 31, 2002

EFFECTIVE DATE: September 18, 2002

Aloa J. Stevens
Director – State Government Affairs
Citizens Communications Company
4 Triad Center, Suite 200
Salt Lake City, Utah 84180

ACCESS SERVICE

15. Wire Center and Interconnection Information (Cont'd)15.1 Serving Wire Center V and H Coordinate Information - Arizona (Cont'd)

<u>LOCALITY</u>	<u>CLLI</u>	<u>WCV</u>	<u>WCH</u>	<u>CC</u>	<u>LATA</u>	<u>OT</u>	<u>NPA</u>	<u>NXX</u>
PHOENIX	PHNXAZNWCG0	9118	6760	5101	666	ABD	602	973
PHOENIX	PHNXAZMACG0	9133	6748	5101	666	ABDE FGHI KLMU VYbd ejo	602	976
PHOENIX	PHNXAZMAO1T	9133	6748	5101	666	BDde i	602	ATO
PHOENIX	PHNXAZMAXXX	9133	6748	5101	666	O	602	DDH
PHOENIX	PHNXAZMAXXX	9133	6748	5101	666	P	602	PAH
PHOENIX	PHNXAZMAXXX	9133	6748	5101	666	Q	602	VDH
PHOENIX 1	PHNXAZMAO1W	9133	6748	5101	666	n	602	PSN
PHOENIX 2	PHNXAZMAO2W	9133	6748	5101	666	n	602	PSN
PIMA	PIMAAZMA485	9154	6319	5101	668	BCe	602	485
PINEDALE	PNDLAZXC739	8876	6469	2177	666	ABCG HPfh j	602	739
PINETOP	PNTPAZXCD0	8901	6404	2177	666	ABCG HPfh j	602	367
PINETOP	PNTPAZXAD0	8901	6398	2177	666	ABCG HPfh j	602	369
PINON- COTTONWOOD	PINNAZXC725	8491	6499	2275	980	Cf	602	725
POLACCA	PLCCAZXC737	8560	6573	2175	666	C	602	737
PORTAL	PRTLZXC55A	9329	6143	2176	668	AC	602	558
POSTON	PSTNAZXC66A	9116	7188	2302	730	Ch	602	662

* New or Revised

Continued

DATE ISSUED: July 31, 2002

EFFECTIVE DATE: September 18, 2002

Aloa J. Stevens
Director – State Government Affairs
Citizens Communications Company
4 Triad Center, Suite 200
Salt Lake City, Utah 84180

ACCESS SERVICE

15. Wire Center and Interconnection Information (Cont'd)15.1 Serving Wire Center V and H Coordinate Information - Arizona (Cont'd)

<u>LOCALITY</u>	<u>CLLI</u>	<u>WCV</u>	<u>WCH</u>	<u>CC</u>	<u>LATA</u>	<u>OT</u>	<u>NPA</u>	<u>NXX</u>
PRESCOTT	PRSCAZSW442	8954	6908	5101	666	BCe	602	442
PRESCOTT	PRSCAZMADS0	8917	6871	5101	666	BDEF GHIK LMUV Ydej o	602	445
PRESCOTT	PRSCAZEARS1	8902	6847	5101	666	BDe	602	772
PRESCOTT	PRSCAZEARS1	8902	6847	5101	666	BD	602	775
PRESCOTT	PRSCAZMADS0	8917	6872	5101	666	BD	602	776
PRESCOTT	PRSCAZMADS0	8917	6871	5101	666	BD	602	778
QUARTZSITE	QRTZAZXC927	9168	7140	2174	730	A	602	927
RED VALLEY	RDVYAZXC653	8344	6385	2275	980	A	602	653
RIVIERA	RVRAAZXC75A	8876	7276	2172	666	ACGH e	602	758
RIVIERA	RVRAAZXC75A	8876	7276	2172	666	ACGH e	602	763
ROBLES	TCSNAZSWMG0	9392	6542	5101	668	BCe	602	822
ROCK POINT	RKPNAZXC659	8342	6489	2275	980	Cf	602	659
ROOSEVELT LAKE	RSVTAZXC467	9049	6593	2171	666	A	602	467
ROUGH ROCK	RHRKAZXC728	8419	6515	2275	980	Cf	602	728
SACATON	SCTNAZMA562	9198	6670	5101	666	BC	602	562
SAFFORD	SFFRAZMAMG0	9163	6295	5101	668	BCe	602	428
SAINTE JOHN'S	STJHAZXCDS0	8798	6326	2177	666	ABCG HPfh j	602	337
SALOME	SALMAZXC859	9121	7039	2174	730	A	602	859
SALT LAKE CITY	SLKCUTMAO1W	7574	7066	5101	660	ABDo	801	PSN
SAN CARLOS	SNCRAZMA475	9086	6454	5101	668	BC	602	475

* New or Revised

Continued

DATE ISSUED: July 31, 2002

EFFECTIVE DATE: September 18, 2002

Aloa J. Stevens
Director – State Government Affairs
Citizens Communications Company
4 Triad Center, Suite 200
Salt Lake City, Utah 84180

ACCESS SERVICE

15. Wire Center and Interconnection Information (Cont'd)15.1 Serving Wire Center V and H Coordinate Information - Arizona (Cont'd)

<u>LOCALITY</u>	<u>CLLI</u>	<u>WCV</u>	<u>WCH</u>	<u>CC</u>	<u>LATA</u>	<u>OT</u>	<u>NPA</u>	<u>NXX</u>
SAN MANUEL	SNMNAZMA385	9252	6447	5101	668	BC	602	385
SAN MANUEL	MMTHAZMA487	9227	6455	5101	668	BC	602	487
SAN MANUEL	ORCLAZMAMG0	9256	6474	5101	668	BC	602	896
SAN SIMON	SNSMAZXC845	9259	6176	2176	668	AC	602	845
SANDERS	SNDRAZMA688	8646	6358	5101	666	BC	602	688
SASABE	SASBAZXC823	9505	6550	2171	668	Ae	602	823
SCOTTSDALE	SCDLAZSHDSO	9095	6712	5101	666	ABD	602	391
SCOTTSDALE	SCDLAZMACG0	9118	6724	5101	666	ABD	602	423
SCOTTSDALE	SCDLAZTHCG0	9102	6728	5101	666	ABD	602	443
SCOTTSDALE	SCDLAZSHDS0	9095	6712	5101	666	ABD	602	451
SCOTTSDALE	SCDLAZMACG0	9118	6724	5101	666	ABD	602	481
SCOTTSDALE	SCDLAZTHCG0	9102	6728	5101	666	ABD	602	483
SCOTTSDALE	PHNXAZNECG0	9121	6737	5101	666	ABDE FGHI KLMU Vdej o	602	840
SCOTTSDALE	SCDLAZSHDSO	9095	6712	5101	666	ABD	602	860
SCOTTSDALE	SCDLAZMACG0	9118	6724	5101	666	ABD	602	941
SCOTTSDALE	SCDLAZMACG0	9118	6724	5101	666	ABD	602	945
SCOTTSDALE	SCDLAZMACG0	9118	6724	5101	666	ABD	602	946
SCOTTSDALE	SCDLAZMACG0	9118	6724	5101	666	ABDE FGHI KLMU Vdej o	602	947
SCOTTSDALE	SCDLAZTHCG0	9102	6728	5101	666	ABDE FGHI KLMU Vdej o	602	948

* New or Revised

Continued

DATE ISSUED: July 31, 2002

EFFECTIVE DATE: September 18, 2002

Aloa J. Stevens
Director – State Government Affairs
Citizens Communications Company
4 Triad Center, Suite 200
Salt Lake City, Utah 84180

ACCESS SERVICE

15. Wire Center and Interconnection Information (Cont'd)15.1 Serving Wire Center V and H Coordinate Information - Arizona (Cont'd)

<u>LOCALITY</u>	<u>CLLI</u>	<u>WCV</u>	<u>WCH</u>	<u>CC</u>	<u>LATA</u>	<u>OT</u>	<u>NPA</u>	<u>NXX</u>
SCOTTSDALE	SCDLAZMACG0	9118	6724	5101	666	ABD	602	949
SCOTTSDALE	SCDLAZTHCG0	9102	6728	5101	666	ABD	602	951
SCOTTSDALE	PHNXAZNECG0	9121	6737	5101	666	ABD	602	952
SCOTTSDALE	PHNXAZNECG0	9121	6737	5101	666	ABD	602	959
SCOTTSDALE	SCDLAZMACG0	9118	6724	5101	666	ABD	602	990
SCOTTSDALE	SCDLAZTHCG0	9102	6728	5101	666	ABD	602	991
SCOTTSDALE	SCDLAZMACG0	9118	6724	5101	666	ABD	602	994
SCOTTSDALE	SCDLAZTHCG0	9102	6728	5101	666	ABD	602	998
SEDONA	SEDNAZMACG0	8820	6763	5101	666	ABDY jo	602	282
SEDONA	SEDNAZSORS1	8841	6758	5101	666	ABDe	602	284
SELIGMAN	SGMNAZMA422	8766	6979	5101	666	BC	602	422
SELLS	SLLSAZXADS0	9450	6636	2173	668	BC	602	383
SHONTO	SHNTAZXC672	8411	6656	2275	980	Cf	602	672
SHOW LOW	SHLWAZXCDS0	8879	6428	2177	666	ABCG HJPF hj	602	537
SIERRA VISTA	SRVSAZSORS1	9471	6319	5101	668	BDe	602	378
SIERRA VISTA	SRVSAZNORS1	9440	6343	5101	668	BD	602	456
SIERRA VISTA	SRVSAZMADS0	9458	6332	5101	668	BD	602	458
SIERRA VISTA	SRVSAZMADS0	9458	6332	5101	668	BD	602	459
SIERRA VISTA	SRVSAZMADS0	9458	6332	5101	668	BD	602	533
SIERRA VISTA	SRVSAZMADS0	9458	6332	5101	668	BDEF GHIK LMUV de	602	538
SILVER BELL	SLBLAZMA324	9334	6591	5101	668	BC	602	324
SNOWFLAKE	SNWFAZXC536	8827	6449	2177	666	ABCG HPfh j	602	536

* *New or Revised**Continued*

DATE ISSUED: July 31, 2002

EFFECTIVE DATE: September 18, 2002

Aloa J. Stevens
 Director – State Government Affairs
 Citizens Communications Company
 4 Triad Center, Suite 200
 Salt Lake City, Utah 84180

ACCESS SERVICE

15. Wire Center and Interconnection Information (Cont'd)15.1 Serving Wire Center V and H Coordinate Information - Arizona (Cont'd)

<u>LOCALITY</u>	<u>CLLI</u>	<u>WCV</u>	<u>WCH</u>	<u>CC</u>	<u>LATA</u>	<u>OT</u>	<u>NPA</u>	<u>NXX</u>
SOMERTON	SMTNAZMA627	9414	7182	5101	666	BCe	602	627
SPRINGERVILLE	SPVLAZXCDSD	8871	6290	2177	666	ABCG HPfh j	602	333
STANFIELD	STFDAZMA424	9249	6700	5101	666	BC	602	424
SUNIZONA	SNZNAZXC824	9361	6232	2176	668	AZ	602	824
SUPAI	SUPAAZXC448	8566	6988	2171	666	A	602	448
SUPERIOR	SPRAZMA689	9125	6562	5101	666	BC	602	689
SUPERSTITION- APACHE	SPRSAZMACG0	9122	6665	5101	666	ABD	602	373
SUPERSTITION- APACHE	SPRSAZMACG0	9122	6665	5101	666	ABD	602	380
SUPERSTITION- APACHE	SPRSAZWECEG0	9125	6685	5101	666	ABD	602	396
SUPERSTITION- APACHE	SPRSAZWECEG0	9125	6685	5101	666	ABD	602	891
SUPERSTITION- APACHE	SPRSAZWECEG0	9125	6685	5101	666	ABDE FGHI KLMU Vdej o	602	981
SUPERSTITION- APACHE	SPRSAZMACG0	9122	6665	5101	666	ABDE FGHI KLMU Vdej o	602	984

* New or Revised

Continued

DATE ISSUED: July 31, 2002

EFFECTIVE DATE: September 18, 2002

Aloa J. Stevens
Director – State Government Affairs
Citizens Communications Company
4 Triad Center, Suite 200
Salt Lake City, Utah 84180

ACCESS SERVICE

5. Wire Center and Interconnection Information (Cont'd)15.1 Serving Wire Center V and H Coordinate Information - Arizona (Cont'd)

<u>LOCALITY</u>	<u>CLLI</u>	<u>WCV</u>	<u>WCH</u>	<u>CC</u>	<u>LATA</u>	<u>OT</u>	<u>NPA</u>	<u>NXX</u>
SUPERSTITION- APACHE	SPRSAZWECG0	9125	6685	5101	666	ABD	602	985
SUPERSTITION- APACHE	SPRSAZMACG0	9122	6665	5101	666	ABD	602	986
SUPERSTITION- APACHE JCT	SPRSAZWECG0	9125	6685	5101	666	ABD	602	924
SUPERSTITION- APACHE JCT	SPRSAZEADS0	9120	6649	5101	666	BCe	602	982
SUPERSTITION- APACHE JCT	SPRSAZEADS0	9120	6649	5101	666	BCe	602	983
TEEC NOS POS	TNPSAZXC656	8279	6412	2275	980	Cfh	602	656
TEMPE	TEMPAZMCCGO	9144	6715	5101	666	ABD	602	345
TEMPE	TEMPAZMACG0	9133	6723	5101	666	ABD	602	350
TEMPE	TEMPAZMCCGO	9144	6715	5101	666	ABD	602	730
TEMPE	TEMPAZMACGO	9133	6723	5101	666	ABDj o	602	731
TEMPE	TEMPAZMCCGO	9144	6715	5101	666	ABD	602	752
TEMPE	TEMPAZMCCGO	9144	6715	5101	666	ABD	602	756
TEMPE	TEMPAZMACGO	9133	6723	5101	666	ABDj o	602	784
TEMPE	TEMPAZMCCGO	9144	6715	5101	666	ABD	602	820
TEMPE	TEMPAZMACGO	9133	6723	5101	666	ABDE FGHI KLMU Vdej o	602	829
TEMPE	TEMPAZMCCGO	9144	6715	5101	666	ABD	602	831

* New or Revised

Continued

DATE ISSUED: July 31, 2002

EFFECTIVE DATE: September 18, 2002

Aloa J. Stevens
 Director – State Government Affairs
 Citizens Communications Company
 4 Triad Center, Suite 200
 Salt Lake City, Utah 84180

ACCESS SERVICE

15. Wire Center and Interconnection Information (Cont'd)15.1 Serving Wire Center V and H Coordinate Information - Arizona (Cont'd)

<u>LOCALITY</u>	<u>CLLI</u>	<u>WCV</u>	<u>WCH</u>	<u>CC</u>	<u>LATA</u>	<u>OT</u>	<u>NPA</u>	<u>NXX</u>
TEMPE	TEMPAZMCCG0	9144	6715	5101	666	ABDE FGHI KLMU Vdej o	602	838
TEMPE	TEMPAZMCCG0	9144	6715	5101	666	ABD	602	839
TEMPE	CHNDAZWEDSO	9158	6721	5101	666	ABDd ejo	602	893
TEMPE	TEMPAZMACG0	9133	6723	5101	666	ABD	602	894
TEMPE	TEMPAZMCCG0	9144	6715	5101	666	ABD	602	897
TEMPE	TEMPAZMACG0	9133	6723	5101	666	ABD	602	921
TEMPE	TEMPAZMACG0	9133	6723	5101	666	ABD	602	965
TEMPE	TEMPAZMACG0	9133	6723	5101	666	ABD	602	966
TEMPE	TEMPAZMACG0	9133	6723	5101	666	ABD	602	967
TEMPE	TEMPAZMACG0	9133	6723	5101	666	ABD	602	968
TOMBSTONE	TMBSAZMA457	9413	6297	5101	668	BC	602	457
TONTO BASIN	TNBSAZXC479	9017	6630	2171	666	AC	602	479
TOYEI	TOYIAZXC736	8566	6485	2275	980	Cf	602	736
TSAILE	TSILAZXC724	8414	6392	2275	980	Cf	602	724
TUBA CITY	TBCYAZXC283	8533	6737	2275	980	Cfh	602	283
TUBAC	TUBCAZMA398	9478	6470	5101	668	BC	602	398
TUCSON	TCSNAZRNCG0	9340	6458	5101	668	ABD	602	290
TUCSON	TCSNAZNOCG0	9320	6498	5101	668	ABD	602	291
TUCSON	TCSNAZFWDS0	9334	6495	5101	668	BCde	602	292
TUCSON	TCSNAZFWDS0	9334	6495	5101	668	BCde	602	293
TUCSON	TCSNAZSOCG0	9364	6483	5101	668	ABDE FGHI KLMU Vdej o	602	294

* *New or Revised**Continued*

DATE ISSUED: July 31, 2002

EFFECTIVE DATE: September 18, 2002

Aloa J. Stevens
 Director – State Government Affairs
 Citizens Communications Company
 4 Triad Center, Suite 200
 Salt Lake City, Utah 84180

ACCESS SERVICE

15. Wire Center and Interconnection Information (Cont'd)15.1 Serving Wire Center V and H Coordinate Information - Arizona (Cont'd)

<u>LOCALITY</u>	<u>CLLI</u>	<u>WCV</u>	<u>WCH</u>	<u>CC</u>	<u>LATA</u>	<u>OT</u>	<u>NPA</u>	<u>NXX</u>
TUCSON	TCSNAZSO CG0	9364	6483	5101	668	ABD	602	295
TUCSON	TCSNAZRNC G0	9340	6458	5101	668	ABDE FGHI KLMU Vdej o	602	296
TUCSON	TCSNAZNO CG0	9320	6498	5101	668	ABD	602	297
TUCSON	TCSNAZRNC G0	9340	6458	5101	668	ABD	602	298
TUCSON	TCSNAZCAC G0	9324	6478	5101	668	ABDd ejo	602	299
TUCSON	TCSNAZEAC G0	9342	6480	5101	668	BD	602	321
TUCSON	TCSNAZEAC G0	9342	6480	5101	668	BD	602	322
TUCSON	TCSNAZEAC G0	9342	6480	5101	668	BD	602	323
TUCSON	TCSNAZEAC G0	9342	6480	5101	668	BD	602	325
TUCSON	TCSNAZEAC G0	9342	6480	5101	668	BD	602	326
TUCSON	TCSNAZEAC G0	9342	6480	5101	668	BDEF GHIK LMUV dejo	602	327
TUCSON	TCSNAZEAC G0	9342	6480	5101	668	BD	602	349
TUCSON	TCSNAZNO CG0	9320	6498	5101	668	ABD	602	429
TUCSON	TCSNAZNO CG0	9320	6498	5101	668	ABD	602	444
TUCSON	TCSNAZNO CG0	9320	6498	5101	668	ABD	602	446
TUCSON	TCSNAZNO CG0	9320	6498	5101	668	ABD	602	447
TUCSON	TCSNAZEAC G0	9342	6480	5101	668	BD	602	449
TUCSON	TCSNAZNO CG0	9320	6498	5101	668	ABD	602	469
TUCSON	TCSNAZCRC G0	9347	6469	5101	668	ABDd e	602	571

* *New or Revised**Continued*

DATE ISSUED: July 31, 2002

EFFECTIVE DATE: September 18, 2002

Aloa J. Stevens
 Director – State Government Affairs
 Citizens Communications Company
 4 Triad Center, Suite 200
 Salt Lake City, Utah 84180

ACCESS SERVICE

15. Wire Center and Interconnection Information (Cont'd)15.1 Serving Wire Center V and H Coordinate Information - Arizona (Cont'd)

<u>LOCALITY</u>	<u>CLLI</u>	<u>WCV</u>	<u>WCH</u>	<u>CC</u>	<u>LATA</u>	<u>OT</u>	<u>NPA</u>	<u>NXX</u>
TUCSON	TCSNAZSOCG0	9364	6483	5101	668	ABD	602	573
TUCSON	TCSNAZSERS1	9365	6460	5101	668	ABDe	602	574
TUCSON	TCSNAZNOCG0	9320	6498	5101	668	ABD	602	575
TUCSON	TCSNAZMLRS1	9293	6466	5101	668	ABDd e	602	576
TUCSON	TCSNAZCACG0	9324	6478	5101	668	ABDd ejo	602	577
TUCSON	TCSNAZSWDS0	9363	6500	5101	668	BCde	602	578
TUCSON	TCSNAZMACG0	9346	6487	5101	668	ABDd ejo	602	620
TUCSON	TCSNAZMACG0	9346	6487	5101	668	ABD	602	621
TUCSON	TCSNAZMACG0	9346	6487	5101	668	ABD	602	622
TUCSON	TCSNAZMACG0	9346	6487	5101	668	ABDE FGHI KLMU VYde jo	602	623
TUCSON	TCSNAZMACG0	9346	6487	5101	668	ABD	602	624
TUCSON	TCSNAZMACG0	9346	6487	5101	668	ABD	602	626
TUCSON	TCSNAZMACG0	9346	6487	5101	668	ABD	602	628
TUCSON	TCSNAZMACG0	9346	6487	5101	668	ABD	602	629
TUCSON	TCSNAZEACG0	9342	6480	5101	668	BD	602	676
TUCSON	TCSNAZMACG0	9346	6487	MNTN	668	ABD	602	694
TUCSON	TCSNAZCDRS1	9340	6458	5101	668	ABD	602	695
TUCSON	TCSNAZRNCG0	9340	6458	5101	668	ABD	602	721
TUCSON	TCSNAZRNCG0	9340	6458	5101	668	ABDd ejo	602	722

* *New or Revised**Continued*

DATE ISSUED: July 31, 2002

EFFECTIVE DATE: September 18, 2002

Aloa J. Stevens
 Director – State Government Affairs
 Citizens Communications Company
 4 Triad Center, Suite 200
 Salt Lake City, Utah 84180

ACCESS SERVICE

15. Wire Center and Interconnection Information (Cont'd)15.1 Serving Wire Center V and H Coordinate Information - Arizona (Cont'd)

<u>LOCALITY</u>	<u>CLLI</u>	<u>WCV</u>	<u>WCH</u>	<u>CC</u>	<u>LATA</u>	<u>OT</u>	<u>NPA</u>	<u>NXX</u>
TUCSON	TCSNAZSO CG0	9364	6483	5101	668	ABD	602	741
TUCSON	TCSNAZNO CG0	9320	6498	5101	668	ABD	602	742
TUCSON	TCSNAZWERS1	9340	6503	5101	668	BC	602	743
TUCSON	TCSNAZCO CG0	9322	6514	5101	668	ABDE FGHI KLMU Vejo	602	744
TUCSON	TCSNAZCR CG0	9347	6469	5101	668	ABD	602	745
TUCSON	TCSNAZSO CG0	9364	6483	5101	668	ABD	602	746
TUCSON	TCSNAZCR CG0	9347	6469	5101	668	ABD	602	747
TUCSON	TCSNAZCR CG0	9347	6469	5101	668	ABD	602	748
TUCSON	TCSNAZTV CG0	9326	6455	5101	668	ABDd ejo	602	749
TUCSON	TCSNAZCR CG0	9347	6469	5101	668	ABD	602	750
TUCSON	TCSNAZRNC G0	9340	6458	5101	668	ABD	602	751
TUCSON	TCSNAZCR CG0	9347	6469	5101	668	ABDE FGHI KLMU Vdej o	602	790
TUCSON	TCSNAZMAC G0	9346	6487	5101	668	ABD	602	791
TUCSON	TCSNAZMAC G0	9346	6487	5101	668	ABD	602	792
TUCSON	TCSNAZNO CG0	9320	6498	5101	668	ABCE FGHI KLMU Vdej o	602	793

* *New or Revised**Continued*

DATE ISSUED: July 31, 2002

EFFECTIVE DATE: September 18, 2002

Aloa J. Stevens
 Director – State Government Affairs
 Citizens Communications Company
 4 Triad Center, Suite 200
 Salt Lake City, Utah 84180

ACCESS SERVICE

5. Wire Center and Interconnection Information (Cont'd)15.1 Serving Wire Center V and H Coordinate Information - Arizona (Cont'd)

<u>LOCALITY</u>	<u>CLLI</u>	<u>WCV</u>	<u>WCH</u>	<u>CC</u>	<u>LATA</u>	<u>OT</u>	<u>NPA</u>	<u>NXX</u>
TUCSON	TCSNAZSO CG0	9364	6483	5101	668	ABD	602	794
TUCSON	TCSNAZEACG0	9342	6480	5101	668	BD	602	795
TUCSON	TCSNAZNO CG0	9320	6498	5101	668	ABD	602	797
TUCSON	TCSNAZMACG0	9346	6487	5101	668	ABD	602	798
TUCSON	TCSNAZSO CG0	9364	6483	5101	668	ABD	602	799
TUCSON	TCSNAZSWDS0	9363	6500	5101	668	BCde	602	822
TUCSON	TCSNAZMACG0	9346	6487	5101	668	ABD	602	880
TUCSON	TCSNAZEACG0	9342	6480	5101	668	BD	602	881
TUCSON	TCSNAZMACG0	9346	6487	5101	668	ABD	602	882
TUCSON	TCSNAZSWDS0	9363	6500	5101	668	BCde	602	883
TUCSON	TCSNAZMACG0	9346	6487	5101	668	ABD	602	884
TUCSON	TCSNAZRNCG0	9340	6458	5101	668	ABD	602	885
TUCSON	TCSNAZRNCG0	9340	6458	5101	668	ABD	602	886
TUCSON	TCSNAZFWDS0	9334	6495	5101	668	BCEF GHIK LMUV de	602	887
TUCSON	TCSNAZFWDS0	9334	6495	5101	668	BC	602	888
TUCSON	TCSNAZSO CG0	9364	6483	5101	668	ABD	602	889
TUCSON	TCSNAZMA04T	9346	6487	5101	668	BDi	602	ATO
TUCSON	TCSNAZMAXXX	9346	6487	5101	668	O	602	DDH
TUCSON	TCSNAZMAXXX	9346	6487	5101	668	P	602	PAH
TUCSON	TCSNAZMAXXX	9346	6487	5101	668	Q	602	VDH
VAIL	VAILAZNO647	9360	6430	5101	668	BCe	602	647
VAIL	VAILAZSODSO	9393	6438	5101	668	BDe	602	762
VIRDEN, NM	DNCNAZNM MG0	9159	6179	5101	668	BCEF GHIK LMUV	505	358

* New or Revised

Continued

DATE ISSUED: July 31, 2002

EFFECTIVE DATE: September 18, 2002

Aloa J. Stevens
 Director – State Government Affairs
 Citizens Communications Company
 4 Triad Center, Suite 200
 Salt Lake City, Utah 84180

ACCESS SERVICE

15. Wire Center and Interconnection Information (Cont'd)15.1 Serving Wire Center V and H Coordinate Information - Arizona (Cont'd)

<u>LOCALITY</u>	<u>CLLI</u>	<u>WCV</u>	<u>WCH</u>	<u>CC</u>	<u>LATA</u>	<u>OT</u>	<u>NPA</u>	<u>NXX</u>
WELLTON	WLTNAZMA785	9377	7082	5101	666	BCe	602	785
WHITE TANKS	WHTKAZMARS1	9144	6819	5101	666	ABDe	602	853
WHITERIVER	WHRVAZXARS1	8942	6496	2177	666	ABCG HPfh j	602	332
WHITERIVER	WHRVAZXC338	8964	6394	2177	666	ABCG HPfh j	602	338
WHITLOW	WHTLAZMADS0	9134	6601	5101	666	BDe	602	463
WICKENBURG	WCBGAZMA684	9049	6890	5101	666	BCde	602	684
WIDE RUIN	WDRNAZXC652	8610	6396	2275	980	Cf	602	652
WIKIEUP	WIKPAZXC765	8919	7079	2172	666	ACGH	602	765
WILLCOX	WLCXAZMA384	9290	6284	5101	668	BCe	602	384
WILLIAMS	WLMSAZMA635	8757	6856	5101	666	BC	602	635
WINDOW ROCK	WNRKAZXC871	8537	6336	2275	980	Cfh	602	871
WINSLOW	WNSLAZMA289	8744	6585	5101	666	BC	602	289
WINTERHAVEN, CA	YUMAAZMADS0	9384	7171	5101	666	ADde	619	572
YARNELL	YRNLAZMA427	8996	6905	5101	666	BCe	602	427
YORK VALLEY	YRVYAZMAMGO	9120	6208	5101	668	BC	602	687
YOUNG	YONGAZMA462	8944	6578	5101	666	BC	602	462
YUCCA	YUCCAZXC766	8908	7182	2172	666	ACGH	602	766
YUMA	YUMAAZMADS0	9384	7171	5101	666	BDde	602	328
YUMA	YUMAAZMADS0	9384	7171	5101	666	BDde	602	329
YUMA	YUMAAZSEMGO	9392	7162	5101	666	BCde	602	341
YUMA	YUMAAZFTDSO	9388	7132	5101	666	BDde	602	342
YUMA	YUMAAZMADS0	9384	7171	5101	666	BDde	602	343
YUMA	YUMAAZSEMGO	9392	7162	5101	666	BCde	602	344
YUMA	YUMAAZSEMGO	9392	7162	5101	666	BCde	602	726

* *New or Revised**Continued*

DATE ISSUED: July 31, 2002

EFFECTIVE DATE: September 18, 2002

Aloa J. Stevens
 Director – State Government Affairs
 Citizens Communications Company
 4 Triad Center, Suite 200
 Salt Lake City, Utah 84180

ACCESS SERVICE

15. Wire Center and Interconnection Information (Cont'd)15.1 Serving Wire Center V and H Coordinate Information - Arizona (Cont'd)

<u>LOCALITY</u>	<u>CLLI</u>	<u>WCV</u>	<u>WCH</u>	<u>CC</u>	<u>LATA</u>	<u>OT</u>	<u>NPA</u>	<u>NXX</u>
YUMA	YUMAAZMADS0	9384	7171	5101	666	BDEF GHIK LMUV Yde	602	782
YUMA	YUMAAZMADS0	9384	7171	5101	666	BDde	602	783

* *New or Revised**Continued*

DATE ISSUED: July 31, 2002

EFFECTIVE DATE: September 18, 2002

Aloa J. Stevens
 Director – State Government Affairs
 Citizens Communications Company
 4 Triad Center, Suite 200
 Salt Lake City, Utah 84180

ACCESS SERVICE

15. Wire Center and Interconnection Information (Cont'd)15.2 Single State Interconnection Information - Arizona

<u>LOCALITY</u>	<u>LC</u>	<u>CC</u>	<u>BP</u>	<u>OI</u>	<u>SVC</u>
ALPINE PHOENIX	ALPIAZXC PHNXAZMA	2177 5101	45 55	END END	SPA/SWD
AUBREY PEAK PHOENIX	AYPEAZQZ PHNXAZMA	2172 5101	0 100	END END	ALL
BLUE RIDGE PHOENIX	BLRGAZXC PHNXAZMA	2171 5101	14 86	END END	ALL
BONITA TUCSON	BONTAZXC TCSNAZMA	2176 5101	40 60	END END	ALL
BOWIE TUCSON	BOWIAZXC TCSNAZMA	2176 5101	31 69	END END	ALL
BULLHEAD CITY AUBREY PEAK	BLCYAZXC AYPEAZQZ	2172 5101	100 0	END END	SWA
BULLHEAD CITY PHOENIX	BLCYAZXC PHNXAZMA	2172 5101	54 46	END END	SPA
CASTLE ROCK AUBREY PEAK	CSRKAZXC AYPEAZQZ	2172 5150	100 0	END END	SWA
CASTLE ROCK PHOENIX	CSRKAZXC PHNXAZMA	2172 5101	53 47	END END	SPA
DOLAN SPRINGS AUBREY PEAK	DLSPA ZXC AYPEAZQZ	2172 5101	100 0	END END	SWA

* *New or Revised**Continued*

DATE ISSUED: July 31, 2002

EFFECTIVE DATE: September 18, 2002

Aloa J. Stevens
 Director – State Government Affairs
 Citizens Communications Company
 4 Triad Center, Suite 200
 Salt Lake City, Utah 84180

ACCESS SERVICE

15. Wire Center and Interconnection Information (Cont'd)15.2 Single State Interconnection Information - Arizona (Cont'd)

<u>LOCALITY</u>	<u>LC</u>	<u>CC</u>	<u>BP</u>	<u>OI</u>	<u>SVC</u>
DOLAN SPRINGS PHOENIX	DLSPA ZXC PHNXAZMA	2172 5101	49 51	END END	SPA
GOLDEN VALLEY AUBREY PEAK	GLVYAZXC AYPEAZQZ	2172 5101	100 0	END END	SWA
GOLDEN VALLEY PHOENIX	GLVYAZXC PHNXAZMA	2172 5101	40 60	END END	SPA
GREEN HAVEN PHOENIX	MRCNAZXE PHNXAZMA	2171 5101	1 99	END END	ALL
GREER PHOENIX	GRERAZXC PHNXAZMA	2177 5101	43 57	END END	SPA/SWD
HARQUAHALA VALLEY PHOENIX	HRVYAZXC PHNXAZMA	2171 5101	7 93	END END	ALL
HAWLEY LAKE PHOENIX	HLLKAZXC PHNXAZMA	2177 5101	27 73	END END	SPA/SWD
HEBER FLAGSTAFF	HEBRAZXC FLGSAZMA	2177 5101	25 75	END END	SPA
HEBER PHOENIX	HEBRAZXC PHNXAZMA	2177 5101	34 66	END END	SPA/SWD
HOLBROOK CAVE CREEK	HLBKAZXC CVCKAZMA	2177 5101	1 99	END END	SPA

* *New or Revised**Continued*

DATE ISSUED: July 31, 2002

EFFECTIVE DATE: September 18, 2002

Aloa J. Stevens
Director – State Government Affairs
Citizens Communications Company
4 Triad Center, Suite 200
Salt Lake City, Utah 84180

ACCESS SERVICE

15. Wire Center and Interconnection Information (Cont'd)15.2 Single State Interconnection Information - Arizona (Cont'd)

<u>LOCALITY</u>	<u>LC</u>	<u>CC</u>	<u>BP</u>	<u>OI</u>	<u>SVC</u>
HOLBROOK FLAGSTAFF	HLBKAZXC FLGSAZMA	2177 5101	1 99	END END	SPA
HOLBROOK JOSEPH CITY	HLBKAZXC JSCYAZMA	2177 5101	1 99	END	SPA
HOLBROOK PHOENIX	HLBKAZXC PHNXAZMA	2177 5101	1 99	END END	SPA/SWD
HOLBROOK WINSLOW	HLBKAZXC WNSLAZMA	2177 5101	1 99	END END	SPA
HAWLEY LAKE PHOENIX	HLLKAZXC PHNXAZMA	2177 5101	27 23	END END	SPA/SWD
HYDER PHOENIX	HYDRAZXC PHNXAZMA	2171 5101	13 87	END END	ALL
KEAMS CANYON PHOENIX	KMCNAZXC PHNXAZMA	2175 5101	23 77	END END	ALL
KINGMAN AUBREY PEAK	KGMNAZXC AYPEAZQZ	2172 5101	100 0	END END	SWA
KINGMAN AUBREY PEAK	KGMNAZXE AYPEAZQZ	2172 5101	100 0	END END	SWA
KINGMAN PHOENIX	KGMNAZXC PHNXAZMA	2172 5101	38 62	END END	SPA

* *New or Revised**Continued*

DATE ISSUED: July 31, 2002

EFFECTIVE DATE: September 18, 2002

Aloa J. Stevens
Director – State Government Affairs
Citizens Communications Company
4 Triad Center, Suite 200
Salt Lake City, Utah 84180

ACCESS SERVICE

15. Wire Center and Interconnection Information (Cont'd)15.2 Single State Interconnection Information - Arizona (Cont'd)

<u>LOCALITY</u>	<u>LC</u>	<u>CC</u>	<u>BP</u>	<u>OI</u>	<u>SVC</u>
KINGMAN	KGMNAZXE	2172	40	END	SPA
PHOENIX	PHNXAZMA	5101	60	END	
KYKOTSMOVI VILLAGE	KIVGAZXC	2175	19	END	ALL
PHOENIX	PHNXAZMA	5101	81	END	
LAKE HAVASU CITY	LHCYAZXC	2172	100	END	SWA
AUBREY PEAK	AYPEAZQZ	5101	0	END	
LAKE HAVASU CITY	LHCYAZXC	2172	59	END	SPA
PHOENIX	PHNXAZMA	5101	41	END	
LAKESIDE	PNTPAZXB	2177	23	END	SPA
PHOENIX	PHNXAZNA	5101	77	END	
MARBLE CANYON	MRCNAZXC	2171	5	END	ALL
PHOENIX	PHNXAZMA	5101	95	END	
MCNARY	MCNRAZXC	2177	24	END	SPA/SWD
PHOENIX	PHNXAZMA	5101	76	END	
MEADVIEW	MDVWAZXC	2172	100	END	SWA
AUBREY PEAK	AYPEAZQZ	5101	0	END	
MEADVIEW	MDVWAZXC	2172	56	END	SPA
PHOENIX	PHNXAZMA	5101	44	END	
MOHAVE VALLEY	MHVYAZXC	2172	100	END	SWA
AUBREY PEAK	AYPEAZQZ	5101	0	END	

* New or Revised

Continued

DATE ISSUED: July 31, 2002

EFFECTIVE DATE: September 18, 2002

Aloa J. Stevens
 Director – State Government Affairs
 Citizens Communications Company
 4 Triad Center, Suite 200
 Salt Lake City, Utah 84180

ACCESS SERVICE

15. Wire Center and Interconnection Information (Cont'd)15.2 Single State Interconnection Information - Arizona (Cont'd)

<u>LOCALITY</u>	<u>LC</u>	<u>CC</u>	<u>BP</u>	<u>OI</u>	<u>SVC</u>
MOHAVE VALLEY PHOENIX	MHVYAZXC PHNXAZMA	2172 5101	50 50	END END	SPA
MOHAVE VALLEY PRESCOTT	MHVYAZXC PRSCAZMA	2172 5101	36 64	END END	SPA
MORMAN LAKE PHOENIX	MMLKAZXC PHNXAZMA	2171 5101	4 96	END END	ALL
PEACH SPRINGS AUBREY PEAK	PCSPA ZXC AYPEAZQZ	2172 5101	100 0	END END	SWA
PEACH SPRINGS PHOENIX	PCSPA ZXC PHNXAZMA	2172 5101	52 48	END END	SPA
PEARCE TUCSON	PERCAZXC TCSNAZMA	2176 5101	9 91	END END	ALL
PINEDALE PHOENIX	PNDLAZXC PHNXAZMA	2177 5101	23 77	END END	SPA/SWD
PINETOP FLAGSTAFF	PNTPAZXC FLGSAZMA	2177 5101	17 83	END END	SPA
PINETOP MESA	PNTPAZXA MESAAZMA	2177 5101	22 78	END END	SPA
PINETOP PHOENIX	PNTPAZXA PHNXAZMA	2177 5101	23 77	END END	SPA/SWD
PINETOP FLAGSTAFF	PNTPAZXC FLGSAZMA	2177 5101	16 84	END END	SPA

* New or Revised

Continued

DATE ISSUED: July 31, 2002

EFFECTIVE DATE: September 18, 2002

Aloa J. Stevens
Director – State Government Affairs
Citizens Communications Company
4 Triad Center, Suite 200
Salt Lake City, Utah 84180

ACCESS SERVICE

15. Wire Center and Interconnection Information (Cont'd)15.2 Single State Interconnection Information - Arizona (Cont'd)

<u>LOCALITY</u>	<u>LC</u>	<u>CC</u>	<u>BP</u>	<u>OI</u>	<u>SVC</u>
PINETOP MESA	PNTPAZXC MESAAZMA	2177 5101	21 79	END END	SPA
PINETOP PHOENIX	PNTPAZXC PHNXAZMA	2177 5101	22 78	END END	SPA/SWD
POLACCA PHOENIX	PLCCAZXC PHNXAZMA	2175 5101	20 80	END END	ALL
PORTAL TUCSON	PRTLAZXC TCSNAZMA	2176 5101	45 55	END END	ALL
RIVIERA AUBREY PEAK	RVRAZZXC AYPEAZQZ	2172 5101	100 0	END END	SWA
RIVIERA PHOENIX	RVRAAZXC PHNXAZMA	2172 5101	53 47	END END	SPA
ROOSEVELT LAKE PHOENIX	RSVTAZXC PHNXAZMA	2171 5101	26 74	END END	ALL
SAN SIMON TUCSON	SNSMAZXC TCSNAZMA	2176 5101	35 65	END END	ALL
SANTA ROSA TUCSON	SNRSAZXA TCSNAZMA	2173 5101	61 39	END END	ALL
SASABE TUCSON	SASBAZXC TCSNAZMA	2171 5101	20 80	END END	ALL

* New or Revised

Continued

DATE ISSUED: July 31, 2002

EFFECTIVE DATE: September 18, 2002

Aloa J. Stevens
Director – State Government Affairs
Citizens Communications Company
4 Triad Center, Suite 200
Salt Lake City, Utah 84180

ACCESS SERVICE

15. Wire Center and Interconnection Information (Cont'd)15.2 Single State Interconnection Information - Arizona (Cont'd)

<u>LOCALITY</u>	<u>LC</u>	<u>CC</u>	<u>BP</u>	<u>OI</u>	<u>SVC</u>
SELLS TUCSON	SLLSAZXA TCSNAZMA	2173 5101	44 56	END END	ALL
SHOW LOW FLAGSTAFF	SHLWAZXC FLGSAZMA	2177 5101	14 86	END END	SPA
SHOW LOW MESA	SHLWAZXC MESAAZMA	2177 5101	18 82	END END	SPA
SHOW LOW PHOENIX	SHLWAZXC PHNXAZMA	2177 5101	19 81	END END	SPA/SWD
SHOW LOW TEMPE	SHLWAZXC TEMPAZMA	2177 5101	19 81	END END	SPA
SNOWFLAKE PHOENIX	SNWFAZXC PHNXAZMA	2177 5101	26 74	END END	SPA/SWD
SPRINGERVILLE FLAGSTAFF	SPVLAZXC FLGSAZMA	2177 5101	32 68	END END	SPA
SPRINGERVILLE PHOENIX	SPVLAZXC PHNXAZMA	2177 5101	41 59	END END	SPA/SWD
SUNIZONA TUCSON	SNZNAZXC TCSNAZMA	2176 5101	17 83	END END	ALL
SUPAI PHOENIX	SUPAAZXC PHNXAZMA	2171 5101	22 78	END END	OPH

* New or Revised

Continued

DATE ISSUED: July 31, 2002

EFFECTIVE DATE: September 18, 2002

Aloa J. Stevens
Director – State Government Affairs
Citizens Communications Company
4 Triad Center, Suite 200
Salt Lake City, Utah 84180

ACCESS SERVICE

15. Wire Center and Interconnection Information (Cont'd)15.2 Single State Interconnection Information - Arizona (Cont'd)

<u>LOCALITY</u>	<u>LC</u>	<u>CC</u>	<u>BP</u>	<u>OI</u>	<u>SVC</u>
SUPAI PRESCOTT	SUPAAZXC PRSCAZMA	2171 5101	39 61	END END	SPA
SAINT JOHNS FLAGSTAFF	STJHAZXC FLGSAZMA	2177 5101	32 68	END END	SPA
SAINT JOHNS MESA	STJHAZXC MESAAZMA	2177 5101	40 60	END END	SPA
SAINT JOHNS PHOENIX	STJHAZXC PHNXAZMA	2177 5101	41 59	END END	SPA/SWD
TONTO BASIN PHOENIX	TNBSAZXC PHNXAZMA	2171 5101	11 89	END END	ALL
WEST SAN SIMON TUCSON	SNRSAZXC TCSNAZMA	2173 5101	62 38	END END	ALL
WHITERIVER PHOENIX	WHRVAZXC PHNXAZMA	2177 5101	28 72	END END	SPA/SWD
WIKIEUP AUBREYPEAK	WIKPAZXC AYPEAZQZ	2172 5101	100 0	END END	SWA
WIKIEUP PHOENIX	WIKPAZXC PHNXAZMA	2172 5101	50 50	END END	SPA
YUCCA AUBREY PEAK	YUCCAZXC AYPEAZQZ	2172 5101	100 0	END END	SWA

* *New or Revised**Continued*

DATE ISSUED: July 31, 2002

EFFECTIVE DATE: September 18, 2002

Aloa J. Stevens
Director – State Government Affairs
Citizens Communications Company
4 Triad Center, Suite 200
Salt Lake City, Utah 84180

ACCESS SERVICE

15. Wire Center and Interconnection Information (Cont'd)15.2 Single State Interconnection Information - Arizona (Cont'd)

<u>LOCALITY</u>	<u>LC</u>	<u>CC</u>	<u>BP</u>	<u>OI</u>	<u>SVC</u>
YUCCA	YUCCAZXC	2172	46	END	SPA
PHOENIX	PHNXAZMA	5101	54	END	

* *New or Revised**Continued*

DATE ISSUED: July 31, 2002

EFFECTIVE DATE: September 18, 2002

Aloa J. Stevens
 Director – State Government Affairs
 Citizens Communications Company
 4 Triad Center, Suite 200
 Salt Lake City, Utah 84180

 ACCESS SERVICE

16. Rates and Charges16.1 Carrier Common Line

Regulations concerning Carrier Common Line
Access Service are set forth in Section 3 preceding.

Premium Access

Originating, per Access Minute – Non 800/888	\$0.010000	(C)
Originating, per Access Minute – 800/888	*	(N)
Terminating, per Access Minute	0	

* See Frontier Telephone Companies Tariff FCC No. 1 for rates.

(N)

Continued

DATE ISSUED: May 11, 2021

EFFECTIVE DATE: July 1, 2021

Senior Vice President
Regulatory Affairs

ACCESS SERVICE

16. Rates and Charges (cont'd)16.2 Switched Access Service

Regulations concerning Switched Access are set forth in Section 6 proceeding. Exceptions to Switched Access rates listed in the Telephone Company's Interstate tariff are as follows:

	<u>Originating</u>	<u>Terminating*</u>
Local Switching (LS1) – Non 800/888	\$0.01716156	
Local Switching (LS2) – Non 800/888	\$0.01716156	
Switched 56Kpbs – Non 800/888	\$0.01716156	
Shared Trunk Port Charge		
- per MOU – Non 800/888	\$0.00130000	
Multiplexers - (Trunk Side of End Office)		
- per MOU – Non 800/888	\$0.00013700	
Interconnection Charge – Non 800/888	\$0.00245000	
Tandem Switched Transport – Non 800/888	\$0.00019900	
Tandem Switched Transport Facility – Non 800/888	\$0.00002300	
Tandem Switching – Non 800/888	\$0.00500000	
800 DB Query, Basic	\$0.00020000	(R)

* See Frontier Telephone Companies Tariff FCC No. 1 for rates.

Continued

DATE ISSUED: May 17, 2023

EFFECTIVE DATE: July 1, 2023

Senior Compliance Manager
Compliance

ACCESS SERVICE

16. Rates and Charges (cont'd)

(D)

(D)

Continued

DATE ISSUED: May 9, 2012

EFFECTIVE DATE: July 1, 2012

Kenneth Mason
Vice President – Government & Regulatory Affairs
Citizens Communications Company
180 S. Clinton Ave.
Rochester, NY 14646

ACCESS SERVICE

16. Rates and Charges (cont'd)

(D)

(D)

Continued

DATE ISSUED: May 9, 2012

EFFECTIVE DATE: July 1, 2012

Kenneth Mason
Vice President – Government & Regulatory Affairs
Citizens Communications Company
180 S. Clinton Ave.
Rochester, NY 14646

ACCESS SERVICE

16. Rates and Charges (cont'd)

(D)

(D)

Continued

DATE ISSUED: May 9, 2012

EFFECTIVE DATE: July 1, 2012

Kenneth Mason
Vice President – Government & Regulatory Affairs
Citizens Communications Company
180 S. Clinton Ave.
Rochester, NY 14646

ACCESS SERVICE

16. Rates and Charges (cont'd)

(D)

(D)

Continued

DATE ISSUED: May 9, 2012

EFFECTIVE DATE: July 1, 2012

Kenneth Mason
Vice President – Government & Regulatory Affairs
Citizens Communications Company
180 S. Clinton Ave.
Rochester, NY 14646

ACCESS SERVICE

16. Rates and Charges (cont'd)

(D)

(D)

Continued

DATE ISSUED: May 9, 2012

EFFECTIVE DATE: July 1, 2012

Kenneth Mason
Vice President – Government & Regulatory Affairs
Citizens Communications Company
180 S. Clinton Ave.
Rochester, NY 14646

ACCESS SERVICE

16. Rates and Charges (cont'd)

(D)

(D)

Continued

DATE ISSUED: May 9, 2012

EFFECTIVE DATE: July 1, 2012

Kenneth Mason
Vice President – Government & Regulatory Affairs
Citizens Communications Company
180 S. Clinton Ave.
Rochester, NY 14646

ACCESS SERVICE

16. Rates and Charges (cont'd)

(D)

(D)

Continued

DATE ISSUED: May 9, 2012

EFFECTIVE DATE: July 1, 2012

Kenneth Mason
Vice President – Government & Regulatory Affairs
Citizens Communications Company
180 S. Clinton Ave.
Rochester, NY 14646

ACCESS SERVICE

16. Rates and Charges (cont'd)

(D)

(D)

Continued

DATE ISSUED: May 9, 2012

EFFECTIVE DATE: July 1, 2012

Kenneth Mason
Vice President – Government & Regulatory Affairs
Citizens Communications Company
180 S. Clinton Ave.
Rochester, NY 14646

ACCESS SERVICE

16. Rates and Charges (cont'd)

(D)

(D)

Continued

DATE ISSUED: May 9, 2012

EFFECTIVE DATE: July 1, 2012

Kenneth Mason
Vice President – Government & Regulatory Affairs
Citizens Communications Company
180 S. Clinton Ave.
Rochester, NY 14646

ACCESS SERVICE

16. Rates and Charges (cont'd)

(D)

(D)

Continued

DATE ISSUED: May 9, 2012

EFFECTIVE DATE: July 1, 2012

Kenneth Mason
Vice President – Government & Regulatory Affairs
Citizens Communications Company
180 S. Clinton Ave.
Rochester, NY 14646

ACCESS SERVICE

16. Rates and Charges (cont'd)16.3 Special Federal Government Access Services16.3.1 Voice Grade Special Access Service

<u>Voice Grade Secure Communications</u>	<u>Monthly Rates</u>	<u>Nonrecurring Charges</u>	<u>Termination Charges</u>
Type I, each T-3 Conditioning,			ICB rates and charges apply
Additional Conditioning, per service termination			ICB rates and charges apply
Type II, each G-1 Conditioning,			ICB rates and charges apply
Type III, each G-2 Conditioning,			ICB rates and charges apply
Additional Conditioning, per service termination			ICB rates and charges apply
Type VI, each G-3 Conditioning,			ICB rates and charges apply
Additional Conditioning, per service termination			ICB rates and charges apply

Continued

DATE ISSUED: July 31, 2002

EFFECTIVE DATE: September 18, 2002

Aloa J. Stevens
 Director – State Government Affairs
 Citizens Communications Company
 4 Triad Center, Suite 200
 Salt Lake City, Utah 84180

ACCESS SERVICE

16. Rates and Charges (cont'd)16.3 Special Federal Government Access Services16.3.2 Wideband Digital Special Access Service

Voice Grade Secure <u>Communications</u>	Monthly <u>Rates</u>	Nonrecurring <u>Charges</u>	Termination <u>Charges</u>
Type I, each	ICB rates and charges apply		
Type II, each	ICB rates and charges apply		
Type III, each	ICB rates and charges apply		

16.3.3 Special Routing Access Services

	Monthly <u>Rates</u>	Nonrecurring <u>Charges</u>
(1) Special Routing Access Service Special Routing Plan Setup, per Switching System	-	\$200.00
(2) Special Routing Access Service Trunk Group Setup, per End Office or Tandem Office, Switching System per occurrence	-	1,000.00
(3) Special Routing Access Service Mode Selection (Active or Deactive), per Switching System per occurrence	-	200.00
(4) Special Routing Access Service Maintenance and Administration, per Switching System per month*	\$150.00	-

* This rate applies only to Switching Systems with this feature.

Continued

DATE ISSUED: July 31, 2002

EFFECTIVE DATE: September 18, 2002

Aloa J. Stevens
Director – State Government Affairs
Citizens Communications Company
4 Triad Center, Suite 200
Salt Lake City, Utah 84180

ACCESS SERVICE

16. Rates and Charges (cont'd)

16.4 Special Facilities Routing of Access Services

16.4.1 Diversity

Individual Case Basis Only

16.4.2 Avoidance

Individual Case Basis Only

16.4.3 Diversity and Avoidance Combined

Individual Case Basis Only

16.4.4 Cable-Only Facilities

Individual Case Basis Only

16.5 Specialized Service or Arrangements

Individual Case Basis Only

Continued

DATE ISSUED: July 31, 2002

EFFECTIVE DATE: September 18, 2002

Aloa J. Stevens
Director – State Government Affairs
Citizens Communications Company
4 Triad Center, Suite 200
Salt Lake City, Utah 84180

ACCESS SERVICE

16.6 Special Access Rates and Charges16.6.1 Metallic Service

	<u>Monthly Rates</u>	<u>Nonrecurring Charge</u>
(A) Circuit Termination - Per Point of Termination	\$23.30	\$141.00
(B) Circuit Mileage Fixed	8.84	-
Per mile	None	-
(C) Optional Features and Functions		
1) Bridging	<u>Monthly Rates</u>	<u>Nonrecurring Charge</u>
(a) Three Premises Bridging - Per Port	\$ 4.33	None
(b) Series Bridging - Per Port	\$ 4.33	None

Continued

DATE ISSUED: July 31, 2002

EFFECTIVE DATE: September 18, 2002

Aloa J. Stevens
Director – State Government Affairs
Citizens Communications Company
4 Triad Center, Suite 200
Salt Lake City, Utah 84180

ACCESS SERVICE

16.6 Special Access Rates and Charges (Cont'd)16.6.2 Voice Grade Service

(A) Circuit Termination	<u>Monthly Nonrecurring Rates</u>	<u>Charge</u>
- Per Point of Termination		
- Two-wire	\$ 23.30	\$ 121.50
0 - Four-wire	29.50	121.50

(B) Circuit Mileage

<u>Miles</u>	<u>Fixed</u>	<u>Per Mile</u>
0 – 8	\$ 9.50	\$ 0.80
8 – 25	\$ 9.50	\$ 0.85
25 – 50	\$ 9.50	\$ 1.05
Over 50	\$ 9.50	\$ 1.10

Continued

DATE ISSUED: July 31, 2002

EFFECTIVE DATE: September 18, 2002

Aloa J. Stevens
Director – State Government Affairs
Citizens Communications Company
4 Triad Center, Suite 200
Salt Lake City, Utah 84180

ACCESS SERVICE

16.6 Special Access Rates and Charges (Cont'd)16.6.2 Voice Grade Service (Cont'd)(D) Optional Features and Functions

Rates and charges for the Optional Features and Functions of Voice Grade Service listed in this section apply to all jurisdictions.

	<u>Monthly Rates</u>	<u>Nonrecurring Charges</u>
(1) Bridging		
(a) <u>Voice Bridging</u>		
- Per port		
- Two-Wire	\$ 4.33	None
- Four-Wire	4.33	None
(b) <u>Data Bridging</u>		
- Per Port		
- Two-Wire	4.33	None
- Four-Wire	4.33	None
(c) <u>Telephoto Bridging</u>		
- Per port		
- Two-Wire	4.33	None
- Four-Wire	4.33	None

Continued

DATE ISSUED: July 31, 2002

EFFECTIVE DATE: September 18, 2002

Aloa J. Stevens
Director – State Government Affairs
Citizens Communications Company
4 Triad Center, Suite 200
Salt Lake City, Utah 84180

ACCESS SERVICE

16.6 Special Access Rates and Charges (Cont'd)16.6.2 Voice Grade Service (Cont'd)(D) Optional Features and Functions (Cont'd)

	<u>Monthly Rates</u>	<u>Nonrecurring Charges</u>
(1) Bridging (Cont'd)		
(d) <u>DATAPHONE Select-A-Station Bridging</u>		
Sequential Arrangement Ports		
- Per Circuit Connected		
- Two-Wire	\$ 24.07	None
- Four-Wire	127.86	None
Addressable Arrangement Ports		
- Per Circuit Connected		
- Two-Wire	25.80	None
- Four-Wire	131.35	None
(e) <u>Telemetry and Alarm Bridging</u>		
Active Bridging Circuit Connections		
- Per Circuit Connected		
- Split Band	9.12	None
- Summation	1.55	None
Passive Bridging Circuit Connections		
- Per Circuit Connected	0.23	None

Continued

DATE ISSUED: July 31, 2002

EFFECTIVE DATE: September 18, 2002

Aloa J. Stevens
Director – State Government Affairs
Citizens Communications Company
4 Triad Center, Suite 200
Salt Lake City, Utah 84180

ACCESS SERVICE

16.6 Special Access Rates and Charges (Cont'd)16.6.2 Voice Grade Service (Cont'd)(D) Optional Features and Functions (Cont'd)

	<u>Monthly Rates</u>	<u>Nonrecurring Charges</u>
(2) Conditioning		
- Per Point of Termination		
- C - Type	\$6.45	None
- Sealing Current	None	None
(3) Improved Return Loss for Effective Four-Wire Transmission		
- Per Point of Termination		
- Two-Wire	1.91	None
- Four-Wire	1.91	None
(4) Customer Specified Receive Level		
- Per Two-Wire Point of Termination	None	None
(5) Multiplexing Voice to Telegraph Grade		
- Per Arrangement	245.68	None
(6) Data Capability		
- Per Point of Termination		
- Two-wire	34.00	None
- Four-wire	27.80	None
(7) Telephoto Capability		
- Per Point of Termination	3.19	None
(8) Signaling Capability		
- Per Point of Termination XSS++	\$14.89	None

Continued

DATE ISSUED: July 31, 2002

EFFECTIVE DATE: September 18, 2002

Aloa J. Stevens
Director – State Government Affairs
Citizens Communications Company
4 Triad Center, Suite 200
Salt Lake City, Utah 84180

ACCESS SERVICE

16.6 Special Access Rates and Charges (Cont'd)16.6.2 Voice Grade Service (Cont'd)(D) Optional Features and Functions (Cont'd)

	<u>Monthly Rates</u>	<u>Nonrecurring Charges</u>
(9) Selective Signaling Arrangement - Per Arrangement	\$15.92	None
(10) Transfer Arrangement (Key Activated* or Dial Up**) - Per Four Port Arrangement, including control circuit termination***	3.41	None
- Per Five Port Arrangement, including control circuit termination***	7.76	None

* The key activated control circuit is rated as a Metallic Circuit Termination (use USOC T6EME in lieu of T6ECS) and Circuit Mileage, if applicable (use USOC 1L5MX in lieu of 1L5XX).

** The Dial-up option requires the customer to purchase the Controller Arrangement (USOC XTDDU) from Section 13.3.8 following.

*** An additional Circuit Termination charge will apply whenever a spare circuit is configured as a leg to the customer's premises. Additional circuit mileage charges will apply when the transfer arrangement is not located in the customer premises serving wire center.

Continued

DATE ISSUED: July 31, 2002

EFFECTIVE DATE: September 18, 2002

Aloa J. Stevens
Director – State Government Affairs
Citizens Communications Company
4 Triad Center, Suite 200
Salt Lake City, Utah 84180

ACCESS SERVICE

16.6 Special Access Rates and Charges (Cont'd)16.6.3 Program Audio Service

	<u>Monthly Rates</u>	<u>Nonrecurring Charge</u>
(A) Circuit Termination		
- Per Point of Termination		
- 200 to 3500 Hz		Rates and charges as shown in Citizens Telecommunications Interstate Access Tariff
- 100 to 5000 Hz		
- 50 to 8000 Hz		
- 50 to 15000 Hz		
(B) Circuit Mileage		
- Fixed		
- 200 to 3500 Hz		Rates and charges as shown in Citizens Telecommunications Interstate Access Tariff
- 100 to 5000 Hz		
- 50 to 8000 Hz		
- 50 to 15000 Hz		
- Per mile		
- 200 to 3500 Hz		Rates and charges as shown in Citizens Telecommunications Interstate Access Tariff
- 100 to 5000 Hz		
- 50 to 8000 Hz		
- 50 to 15000 Hz		

Continued

DATE ISSUED: July 31, 2002

EFFECTIVE DATE: September 18, 2002

Aloa J. Stevens
Director – State Government Affairs
Citizens Communications Company
4 Triad Center, Suite 200
Salt Lake City, Utah 84180

ACCESS SERVICE

16.6 Special Access Rates and Charges (Cont'd)

16.6.3 Program Audio Service (Cont'd)

	<u>Daily Rates*</u>
(B) Circuit Mileage	
- Fixed	
- 200 to 3500 Hz	Rates as shown in Citizens Telecommunications Interstate Tariff
- 100 to 5000 Hz	
- 50 to 8000 Hz	
- 50 to 15000 Hz	
- Per mile	
- 200 to 3500 Hz	Rates as shown in Citizens Telecommunications Interstate Tariff
- 100 to 5000 Hz	
- 50 to 8000 Hz	
- 50 to 15000 Hz	
(C) Optional Features and Functions	

Rates and charges for the Optional Features and Functions of Program Audio Service listed in this section apply to all jurisdictions.

* Daily Rates will be topped and maximum rates derived as set forth in 7.2.3(A) preceding.

Continued

DATE ISSUED: July 31, 2002

EFFECTIVE DATE: September 18, 2002

Aloa J. Stevens
Director – State Government Affairs
Citizens Communications Company
4 Triad Center, Suite 200
Salt Lake City, Utah 84180

ACCESS SERVICE

16.6 Special Access Rates and Charges (Cont'd)16.6.3 Program Audio Service (Cont'd)

(C) Optional Features and Functions (Cont'd)

	<u>Monthly Rates</u>	<u>Daily* Rates</u>
- Bridging, Dis- tribution		
- Amplifier - Per Port	Rates and charges as shown in Citizens Tele- communications Interstate Tariff	Rates and charges as shown in Citizens Tele- communi- cations Interstate Tariff
- Gain Condi- tioning - Per Service	Rates and charges as shown in Citizens Tele- communications Interstate Tariff	Rates and charges as shown in Citizens Tele- communi- cations Interstate Tariff
- Stereo - Per Service	None	None

* Daily rates will be topped and maximum rates derived as set forth in 7.2.3(A) preceding.

Continued

DATE ISSUED: July 31, 2002

EFFECTIVE DATE: September 18, 2002

Aloa J. Stevens
Director – State Government Affairs
Citizens Communications Company
4 Triad Center, Suite 200
Salt Lake City, Utah 84180

ACCESS SERVICE

16.6 Special Access Rates and Charges (Cont'd)16.6.4 Video Services(A) Circuit Termination

- Per Point of Termination

Monthly Rates and Nonrecurring Charges for all jurisdictions will be determined on an Individual Case Basis and filed in Section 16.6.8 following.

Available frequency bandwidths and USOC formats are as follows:

<u>Frequency Bandwidths</u>	<u>USOC</u>
- TV - 1 or 2	TWT++
- 4TV - 5	TWT++
- 6TV - 5	TWT++
- TV - 15	TWT++

Continued

DATE ISSUED: July 31, 2002

EFFECTIVE DATE: September 18, 2002

Aloa J. Stevens
Director – State Government Affairs
Citizens Communications Company
4 Triad Center, Suite 200
Salt Lake City, Utah 84180

ACCESS SERVICE

16.6 Special Access Rates and Charges (Cont'd)16.6.4 Video Services (Cont'd)(B) Circuit Mileage

Fixed and Per Mile Monthly Rates for all jurisdictions will be determined on an Individual Case Basis and filed in 16.6.8 following.

Available mileage bands and USOC formats are as follows:

<u>Mileage Bands</u>	<u>USOC</u>
0	1LO++
Over 0 to 4	1LO++
Over 4 to 8	1LO++
Over 8 to 25	1LO++
Over 25 to 50	1LO++
Over 50	1LO++

Continued

DATE ISSUED: July 31, 2002

EFFECTIVE DATE: September 18, 2002

Aloa J. Stevens
Director – State Government Affairs
Citizens Communications Company
4 Triad Center, Suite 200
Salt Lake City, Utah 84180

ACCESS SERVICE

16.6 Special Access Rates and Charges (Cont'd)16.6.5 Wideband Analog Service(A) Circuit Termination

- Per Point of Termination

Monthly Rates and Nonrecurring Charges for all jurisdictions will be determined on an Individual Case Basis and filed in Section 16.6.8 following.

Available frequency bandwidths and USOC formats are as follows:

<u>Frequency Bandwidths</u>	<u>USOC</u>
60 kHz - 108 kHz	TWT++
312 kHz - 552 kHz	TWT++
564 kHz - 3084 kHz	TWT++
300 Hz - 18 kHz	TWT++
29 kHz - 44 kHz	TWT++

(B) Circuit Mileage

Fixed and Per Mile Monthly Rates for all jurisdictions will be determined on an Individual Case Basis and filed in Section 16.6.8 following.

Available bandwidths and USOC formats are as follows.

<u>Frequency Bandwidths</u>	<u>USOC</u>
60 kHz - 108 kHz	1LO++
312 kHz - 552 kHz	1LO++
564 kHz - 3084 kHz	1LO++
300 Hz - 18 kHz	1LO++
29 kHz - 44 kHz	1LO++

Continued

DATE ISSUED: July 31, 2002

EFFECTIVE DATE: September 18, 2002

Aloa J. Stevens
Director – State Government Affairs
Citizens Communications Company
4 Triad Center, Suite 200
Salt Lake City, Utah 84180

ACCESS SERVICE

16.6 Special Access Rates and Charges (Cont'd)16.6.5 Wideband Analog Service (Cont'd)(C) Optional Features and Functions

(1) Multiplexing

Fixed and Per Mile Monthly Rates for all jurisdictions will be determined on an Individual Case Basis and filed in 16.6.8 following.

Available multiplexing arrangements and USOC formats are as follows:

<u>Multiplexing Arrangement</u>	<u>USOC (Per Arrangement)</u>
Mastergroup to Supergroup	MQ9++
Supergroup to Group	MQS++
Group to Voice	MQV++
Group to DS1*	MQG++

- * Requires two 60-108 kHz Circuit Terminations and Circuit Mileage, one 1.544 Mbps Circuit Mileage and either a 1.544 Circuit Termination or a DS1 to Voice Multiplexing optional feature, depending on whether the service terminates at a customer's premise or was purchased as a facility, to a Telephone Company hub for multiplexing to Voice Grade.

Continued

DATE ISSUED: July 31, 2002

EFFECTIVE DATE: September 18, 2002

Aloa J. Stevens
Director – State Government Affairs
Citizens Communications Company
4 Triad Center, Suite 200
Salt Lake City, Utah 84180

ACCESS SERVICE

16.6 Special Access Rates and Charges (Cont'd)16.6.6 Digital Data Service

	<u>Monthly Rates</u>	<u>Nonrecurring Charge</u>
(A) Circuit Termination		
- Per Point of Termination		
- 2.4 kbps	\$ 52.11	-
- 4.8 kbps	52.11	-
- 9.6 kbps	52.11	-
- 56.0 kbps	56.45	-
(B) Circuit Mileage		
- Fixed		
- 2.4 kbps	8.84	-
- 4.8 kbps	8.84	-
- 9.6 kbps	8.84	-
-56.0 kbps	17.68	-
- Per mile		
- 2.4 kbps	2.80	-
- 4.8 kbps	2.80	-
- 9.6 kbps	2.80	-
- 56.0 kbps	5.60	-

Continued

DATE ISSUED: July 31, 2002

EFFECTIVE DATE: September 18, 2002

Aloa J. Stevens
Director – State Government Affairs
Citizens Communications Company
4 Triad Center, Suite 200
Salt Lake City, Utah 84180

ACCESS SERVICE

 16.6 Special Access Rates and
Charges (Cont'd)

16.6.6 Digital Data Service(C) Optional Features and Functions

Monthly Rates and Nonrecurring Charges for the Optional Features and Functions of Digital Data Service listed in this section apply to all jurisdictions.

<u>Optional Features and Functions</u>	<u>Monthly Rates</u>	<u>Nonrecurring Charges</u>
(1) Bridging - Per Port	\$ 26.93	None
(2) Loop Transfer Arrangement (Key Activated* or Dial-Up**) - Per Four-Port Arrangement***	6.75	None

* The key activated control is rated as a Metallic Circuit Termination (Use USOC T6EME in lieu of T6ECS) and Circuit Mileage, if applicable (Use USOC 1L5MX in lieu of 1L5XX).

** The Dial-Up option requires the customer to purchase the Controller Arrangement (USOC XTDDU) from Section 8.6(A) following.

*** An additional Circuit Termination charge will apply whenever a spare circuit is configured as a leg to the customer's premises. Additional Circuit Mileage charges will also apply when the transfer arrangement is not located in the customer premises serving wire center.

Continued

DATE ISSUED: July 31, 2002

EFFECTIVE DATE: September 18, 2002

Aloa J. Stevens
Director – State Government Affairs
Citizens Communications Company
4 Triad Center, Suite 200
Salt Lake City, Utah 84180

ACCESS SERVICE

16.6 Special Access Rates and Charges (Cont'd)16.6.6 Digital Data Service (Cont'd)(D) Channel Service Unit

Monthly Rates and Nonrecurring Charges for the Channel Service Unit* of Digital Data Service listed in this section apply to all jurisdictions.

<u>Channel Service Limit*</u>	<u>Monthly Rate</u>	<u>Nonrecurring Charge</u>
- Per Point of Termination where provided		
- 2.4 Kbps	\$18.60	None
- 4.8 Kbps	19.88	None
- 9.6 Kbps	20.85	None
- 56.0 Kbps	21.73	None

Continued

DATE ISSUED: July 31, 2002

EFFECTIVE DATE: September 18, 2002

Aloa J. Stevens
Director – State Government Affairs
Citizens Communications Company
4 Triad Center, Suite 200
Salt Lake City, Utah 84180

ACCESS SERVICE

16.6 Special Access Rates and Charges (Cont'd)16.6.7 High Capacity Service

	<u>Monthly Rates</u>	<u>Nonrecurring Charge</u>
(A) Circuit Termination - Per Point of Termination 1.544 Mbps	\$209.73	\$388.00

Frequency bandwidths other than 1.544 mbps:

Monthly Rates and Nonrecurring Charges for the Circuit Termination rate element of High Capacity Service for all jurisdictions will be determined on an Individual Case Basis and filed in Section 16.1.10 following.

<u>Frequency Bandwidths</u>	<u>USOC</u>
64 Kbps	TWT++
3.152 Mbps	TWT++
6.312 Mbps	TWT++
44.736 Mbps	TWT++
274.176 Mbps	TWT++

Continued

DATE ISSUED: July 31, 2002

EFFECTIVE DATE: September 18, 2002

Aloa J. Stevens
Director – State Government Affairs
Citizens Communications Company
4 Triad Center, Suite 200
Salt Lake City, Utah 84180

ACCESS SERVICE16.6 Special Access Rates and Charges (Cont'd)16.6.7 High Capacity Service (Cont'd)

	<u>Monthly Rates</u>
(B) Circuit Mileage 1.544 Mbps - Fixed	\$ 51.70
- Per mile	42.90

For frequency bandwidths other than 1.544 Mbps:

Fixed and Per Mile Monthly Rates for the Circuit Mileage rate element of High Capacity Service for all jurisdictions will be determined on an Individual Case Basis and filed in 16.6.8 following.

<u>Frequency Bandwidths</u>	<u>USOC</u>
64 Kbps	1L5XX (Fixed), 1L5XX (Per Mile)
3.152 Mbps	1LO++
6.312 Mbps	1LO++
44.736 Mbps	1LO++
274.176 Mbps	1LO++

(C) Optional Features and Functions

Rates and charges for the Optional Features and Functions of High Capacity Service listed in this section apply to all jurisdictions.

Continued

DATE ISSUED: July 31, 2002

EFFECTIVE DATE: September 18, 2002

Aloa J. Stevens
Director – State Government Affairs
Citizens Communications Company
4 Triad Center, Suite 200
Salt Lake City, Utah 84180

ACCESS SERVICE

16.6 Special Access Rates and Charges (Cont'd)16.6.7 High Capacity Service (Cont'd)(C) Optional Features and Functions (Cont'd)

	<u>Monthly Rates</u>	<u>Installation Charges</u>
(1) Multiplexing DS4 to DS1 - Per arrangement	ICB	None
DS3 to DS1 - Per arrangement	ICB	None
DS2 to DS1 - Per arrangement	ICB	None
DS1C to DS1 - Per arrangement	ICB	None
DS1 to Voice* - Per arrangement	\$360.44	None
DS1 TO DSO - Per arrangement	624.91	None
DSO to Subrates - Per arrangement Up to 20 2.4 kpbs services	511.06	None
Up to 10 4.8 kpbs services	263.41	None
Up to 5 9.6 kpbs services	183.12	None

* A circuit of this DS1 to the hub can be used for Digital Data service. ICB rates and charges are filed in 16.6.8 following.

Continued

DATE ISSUED: July 31, 2002

EFFECTIVE DATE: September 18, 2002

Aloa J. Stevens
Director – State Government Affairs
Citizens Communications Company
4 Triad Center, Suite 200
Salt Lake City, Utah 84180

ACCESS SERVICE

16.6 Special Access Rates and Charges (Cont'd)16.6.7 High Capacity Service (Cont'd)(D) Network Channel Terminating Equipment (NCTE)#

	<u>Monthly Rates</u>	<u>Installation Charges</u>
- Per Point of termination where provided		
- 1.544 Mbps	\$ 96.02	None
- Automatic Loop Transfer	1,013.35	None

Continued

DATE ISSUED: July 31, 2002

EFFECTIVE DATE: September 18, 2002

Aloa J. Stevens
Director – State Government Affairs
Citizens Communications Company
4 Triad Center, Suite 200
Salt Lake City, Utah 84180

ACCESS SERVICE16.6 Special Access Rates and Charges (Cont'd)16.6.7 High Capacity Service (Cont'd)(C) Optional Features and Functions (Cont'd)

	<u>Rates</u>	<u>Installation Charges</u>
(2) Automatic Loop Transfer - Per arrangement*	\$ 440.13	None
(3) Transfer Arrangement (key activated** or dial up***) - Per four port arrangement including control channel termination****)	187.03	None

16.6.8 Individual Case Filing

Rates and Charges for Special Access Service provided on an individual case basis are filed following:

- * An additional Circuit Termination charge will apply whenever the spare line is provided as a leg to the customer premises.
- ** The key activated control circuit is rated as a Metallic Circuit Termination (use USOC 1L5MX in lieu of 1L5XX).
- *** The Dial-up option requires the customer to purchase the Controller Arrangement (USOC XTDDU) from Section 8.7 following.
- **** An additional Circuit Termination charge will apply whenever a spare circuit is configured as a leg to the customers premises. Additional circuit mileage charges will also apply when the transfer arrangement is not located in the customer premises serving wire center.

Continued

DATE ISSUED: July 31, 2002

EFFECTIVE DATE: September 18, 2002

Aloa J. Stevens
Director – State Government Affairs
Citizens Communications Company
4 Triad Center, Suite 200
Salt Lake City, Utah 84180

 ACCESS SERVICE

16. Rates and Charges (cont'd)16.7 Miscellaneous Services16.7.1 Charges for Additional EngineeringPer Engineer, Per Hour, or Fraction ThereofBasic TimeOvertime

\$60.00

\$90.00

16.7.2 Charges for Additional LaborPer Technician, Each Hour, or Fraction ThereofBasic TimeOvertime

\$60.00

\$90.00

Continued

DATE ISSUED: July 31, 2002

EFFECTIVE DATE: September 18, 2002

Aloa J. Stevens
 Director – State Government Affairs
 Citizens Communications Company
 4 Triad Center, Suite 200
 Salt Lake City, Utah 84180

 ACCESS SERVICE

16. Rates and Charges (cont'd)16.7 Miscellaneous Services (cont'd)16.7.3 Charges For Additional Testing

The charges for Additional Testing are as follows:

Per Technician, Per Hour, or Fraction Thereof

<u>Basic Time</u>	<u>Overtime</u>
\$60.00	\$90.00

16.7.4 Presubscription Charge

The nonrecurring charge for Presubscription is as follows:

	<u>Nonrecurring Charge</u>
Presubscription, per Telephone Exchange Service line or trunk	\$5.00

Continued

 DATE ISSUED: July 31, 2002

EFFECTIVE DATE: September 18, 2002

Aloa J. Stevens
 Director – State Government Affairs
 Citizens Communications Company
 4 Triad Center, Suite 200
 Salt Lake City, Utah 84180

ACCESS SERVICE

16. Rates and Charges (cont'd)16.7 Miscellaneous Services (cont'd)16.7.5 Protective Connecting Arrangements

The following Protective Connecting Arrangements (PCAs) are grandfathered and are offered on the basis of on-the-shelf availability:

<u>Description</u>	<u>Monthly Rates</u>	<u>Nonrecurring Charges</u>
Automatic PCA with a contact type signaling interface for two or four-wire voice band connections of CPE communications systems to Telephone Company Special Access Services.	\$ -	\$ 5.85
Automatic PCA for connection of a customer, authorized user or joint user provided communications system arranged for CPE dial or automatic channel signaling, to a Telephone Company Special Access Service which terminates at the distant end in a telephone company-provided PBX arranged for dial or automatic signaling (Four-wire).	10.10	87.15
PCA which provides for connection of CPE automatic telephone answering devices to central office, PBX trunk, key system lines, and centrex station lines by means of a two-wire interface.	ICB rates and charges apply	
PCA for connection of CPE answering or recording equipment to Telephone Company lines, for one-way voice transmission in each direction but not simultaneously. Recording of two-way conversations is prevented, by the PCA.	5.40	30.75

Continued

DATE ISSUED: July 31, 2002

EFFECTIVE DATE: September 18, 2002

Aloa J. Stevens
Director – State Government Affairs
Citizens Communications Company
4 Triad Center, Suite 200
Salt Lake City, Utah 84180

ACCESS SERVICE

16. Rates and Charges (cont'd)16.7 Miscellaneous Services (cont'd)16.7.5 Protective Connecting Arrangements (cont'd)

<u>Description</u>	<u>Monthly Rates</u>	<u>Nonrecurring Charges</u>
PCA for use with CPE answer only equipment where two-way transmission is required.		ICB rates and charges apply
Same application as PFZ++ with voice control disconnect and automatic receive volume limiting.		ICB rates and charges apply
PCA for use with CPE to provide data on PBX trunks. Also requires standard PBX trunk PCA.		ICB rates and charges apply
PCA to permit connection of CPE message registers to exchange facilities of the Telephone Company for indications of message registration for outgoing calls over the associated central office trunks (facilities). Each trunk would also have a PCA (typically CDH or CD8) for connection of the CPE PBX. Association of the trunk with the station is made by the CPE.		ICB rates and charges apply

Continued

DATE ISSUED: July 31, 2002

EFFECTIVE DATE: September 18, 2002

Aloa J. Stevens
 Director – State Government Affairs
 Citizens Communications Company
 4 Triad Center, Suite 200
 Salt Lake City, Utah 84180

ACCESS SERVICE

16. Rates and Charges (cont'd)16.7 Miscellaneous Services (cont'd)16.7.5 Protective Connecting Arrangements (cont'd)

<u>Description</u>	<u>Monthly Rates</u>	<u>Nonrecurring Charges</u>
Alarm coupler for use with rotary dial, one-way transmission CPE alarm signaling device. ICB rates and charges apply		
PCA to permit the connection of CPE to a Telephone Company special recording trunk arranged for two-way service, i.e., outward dialing by hotel/motel guests and re-ringing by the operator of the Telephone Company long distance switchboard (the equivalent of a toll terminal). ICB rates and charges apply		
For termination of CPE tie lines, with CPE channel signaling, in Centrex systems four-wire.	\$7.20	\$21.60
PCA used for automatic connection of CPE voice transmitting and/or receiving terminal equipment to an exchange line or PBX/CTX station line, or to a WATS Access Line.	9.40	7.80

Continued

DATE ISSUED: July 31, 2002

EFFECTIVE DATE: September 18, 2002

Aloa J. Stevens
 Director – State Government Affairs
 Citizens Communications Company
 4 Triad Center, Suite 200
 Salt Lake City, Utah 84180

ACCESS SERVICE

16. Rates and Charges (cont'd)16.7 Miscellaneous Services (cont'd)16.7.5 Protective Connecting Arrangements (cont'd)

<u>Description</u>	<u>Monthly Rates</u>	<u>Nonrecurring Charges</u>
PCA to provide for connection of CPE terminal equipment to Telephone Company central office key system and PBX station lines and WATS Access Lines via two or four-wire interface.	ICB rates and charges apply	
PCA for connection of CPE voice communications systems and/or terminal equipment via two-wire interface to Telephone Company lines and trunks (only loop start trunks not equipped for toll diversion), or terminal	ICB rates and charges apply	
Manual PCA used to connect a cord switchboard position of CPE system, which provides supervisory signals, to an exchange trunk line.	ICB rates and charges apply	
Automatic PCA used to connect an exchange trunk line arranged for two-way combination service to and from the attendant position and from the dial switching equipment of a CPE	\$10.45	\$39.05

Continued

DATE ISSUED: July 31, 2002

EFFECTIVE DATE: September 18, 2002

Aloa J. Stevens
 Director – State Government Affairs
 Citizens Communications Company
 4 Triad Center, Suite 200
 Salt Lake City, Utah 84180

ACCESS SERVICE

16. Rates and Charges (cont'd)16.7 Miscellaneous Services (cont'd)16.7.5 Protective Connecting Arrangements (cont'd)

<u>Description</u>	<u>Monthly Rates</u>	<u>Nonrecurring Charges</u>
Automatic PCA used to connect an exchange trunk line arranged for one-way incoming service to the attendant position of a CPE system	ICB rates and charges apply	
Automatic PCA used to connect an exchange trunk line arranged for one-way outgoing service from the attendant position of a CPE system	ICB rates and charges apply	
Automatic PCA used to connect an exchange trunk line arranged for one-way outgoing service from the dial switching equipment of a CPE system.	ICB rates and charges apply	
Automatic PCA used to connect an exchange trunk line arranged for one-way service, to and from the attendant position of a CPE system.	\$7.80	\$39.05
PCA used for automatic connecting of CPE voice transmitting and/or receiving terminal equipment bridged to an exchange line or PBX/CTX station line, or to a Switched Access Line, e.g., WATS access line, which is terminated in a Telephone Company station.	9.40	7.80

Continued

DATE ISSUED: July 31, 2002

EFFECTIVE DATE: September 18, 2002

Aloa J. Stevens
 Director – State Government Affairs
 Citizens Communications Company
 4 Triad Center, Suite 200
 Salt Lake City, Utah 84180

ACCESS SERVICE

16. Rates and Charges (cont'd)16.7 Miscellaneous Services (cont'd)16.7.5 Protective Connecting Arrangements (cont'd)

<u>Description</u>	<u>Monthly Rates</u>	<u>Nonrecurring Charges</u>
Automatic PCA used to connect an exchange trunk line, arranged for one-way service, i.e., out-ward dialing by hotel/motel guests to the operator position of a Telephone Company long distance switchboard (the equivalent of a toll terminal).	ICB rates and charges apply	
PCA to provide for connection of CPE originate only or originate and answer terminal equipment.	ICB rates and charges apply	

16.7.6 Controller Arrangement

Per arrangement	\$100.00
-----------------	----------

16.7.7 Telecommunications Service Priority (TSP)

(T)

Nonrecurring Charge

TSP priority, per service arranged	\$54.63
------------------------------------	---------

(T)

* *New or Revised**Continued*

DATE ISSUED: August 30, 2007

EFFECTIVE DATE: October 1, 2007

Aloa J. Stevens
 Director –Government & External Affairs
 Citizens Communications Company
 P.O. Box 708970
 Sandy, Utah 84070

ACCESS SERVICE

16. Rates and Charges (cont'd)16.7 Miscellaneous Services (cont'd)16.7.8 Standard Jacks – Registration Program16.7.8.1 Standard Voice Jacks

<u>Description</u>	<u>Nonrecurring Charges</u>
(1) Miniature six-position jacks for connection of terminal equipment as follows:	
(a) Single line telephone set surface or flush mounted.	\$ 10.00
(b) Single line telephone sets wall mounted.	10.00
(c) Two-line nonkey telephone sets surface or flush mounted.	10.00
(d) Single-line bridged four-wire exchange 2/RT, T1/R1.	10.00
(e) Two-line nonkey telephone sets wall mounted.	10.00
(f) Special single line equipment for use in hospital critical care areas.	10.00

Continued

DATE ISSUED: July 31, 2002

EFFECTIVE DATE: September 18, 2002

Aloa J. Stevens
Director – State Government Affairs
Citizens Communications Company
4 Triad Center, Suite 200
Salt Lake City, Utah 84180

ACCESS SERVICE

16. Rates and Charges (cont'd)16.7 Miscellaneous Services (cont'd)16.7.8 Standard Jacks – Registration Program (cont'd)16.7.8.1 Standard Voice Jacks (cont'd)

<u>Description</u>	<u>Nonrecurring Charges</u>
(g) 9DB single line data equipment with mode indication and mode indication common leads. This jack is normally used in association with a series jack.	\$10.00
(h) Three-line non-key telephone sets and ancillary devices.	49.00
(2) 50 Position Miniature Ribbon for connection of multiline terminating equipment and channel derivation devices as follows:	
(a) For connection to two-wire tie trunks E&M type I signaling. (12 line capacity)	160.00
(b) For connection to four-wire tie trunks E&M type I signaling. (8 line capacity)	160.00

Continued

DATE ISSUED: July 31, 2002

EFFECTIVE DATE: September 18, 2002

Aloa J. Stevens
Director – State Government Affairs
Citizens Communications Company
4 Triad Center, Suite 200
Salt Lake City, Utah 84180

ACCESS SERVICE

16. Rates and Charges (cont'd)16.7 Miscellaneous Services (cont'd)16.7.8 Standard Jacks – Registration Program (cont'd)16.7.8.1 Standard Voice Jacks (cont'd)

<u>Description</u>	<u>Nonrecurring Charges</u>
(2) 50 Position Miniature Ribbon for connection of multiline terminating equipment and channel derivation devices as follows (cont'd):	
(c) For connection to two-wire tie trunks E&M type II signaling. (8 line capacity)	\$160.00
(d) For connection to four-wire tie trunks E&M type II signaling. (6 line capacity)	160.00
(e) For connection to off-premises station lines. (25 line capacity)	160.00
(f) For use with series devices such as toll restrictors. (12 line capacity)	105.00
(g) For connection of up to 12 line bridged four-wire exchange 2/RT, T1/R1.	100.00

Continued

DATE ISSUED: July 31, 2002

EFFECTIVE DATE: September 18, 2002

Aloa J. Stevens
Director – State Government Affairs
Citizens Communications Company
4 Triad Center, Suite 200
Salt Lake City, Utah 84180

ACCESS SERVICE

16. Rates and Charges (cont'd)16.7 Miscellaneous Services (cont'd)16.7.8 Standard Jacks – Registration Program (cont'd)16.7.8.1 Standard Voice Jacks (cont'd)

<u>Description</u>	<u>Nonrecurring Charges</u>
(3) Series Jacks for connection of terminal equipment as follows:	
(a) Single line alarm reporting devices.	\$ 66.00
(b) Series ancillary devices such as automatic dialers. Single line sets with exclusion.	66.00
(c) Two line telephone sets with exclusion on one line.	66.00
(4) Weatherproof Jack for use with single line telephone sets used at locations such as boats and marinas.	120.00

Continued

DATE ISSUED: July 31, 2002

EFFECTIVE DATE: September 18, 2002

Aloa J. Stevens
Director – State Government Affairs
Citizens Communications Company
4 Triad Center, Suite 200
Salt Lake City, Utah 84180

ACCESS SERVICE

16. Rates and Charges (cont'd)16.7 Miscellaneous Services (cont'd)16.7.8 Standard Jacks – Registration Program (cont'd)16.7.8.2 Standard Data Jacks

	<u>Nonrecurring Charges</u>
(1) Universal Data Jack for use in connecting fixed loss loop (FLL) and programmed (P) types of data equipment. (1 line capacity)	\$65.00
(2) Programmed Data Jack for use in connecting programmed data equipment. (1 line capacity)	65.00
(3) Multiple Line Universal Data Jack for use in connecting fixed loss loop (FLL) and programmed (P) types of data equipment. This jack will terminate up to eight lines. The selection of this jack requires the use of the equipment listed following.	250.00

Continued

DATE ISSUED: July 31, 2002

EFFECTIVE DATE: September 18, 2002

Aloa J. Stevens
Director – State Government Affairs
Citizens Communications Company
4 Triad Center, Suite 200
Salt Lake City, Utah 84180

ACCESS SERVICE

16. Rates and Charges (cont'd)16.7 Miscellaneous Services (cont'd)16.7.8 Standard Jacks – Registration Program (cont'd)16.7.8.2 Standard Data JacksNonrecurring
Charges

(3) Multiple Line Universal Data Jack for use in connecting fixed loss loop (FLL) and programmed (P) types of data equipment. This jack will terminate up to eight lines. The selection of this jack requires the use of the equipment listed following. (cont'd)

(a) Multiple Line Universal Data Jack Circuit Cards. For use with RJ26X. One circuit card per circuit required.

\$79.00

(b) Multiple Line Universal Data Jacking Mounting options. For use with RJ26X. One required per RJ26X.

Wall Mounting
with cover.

45.00

Rack Mounting
(19 inch or 23 inch)

28.00

Continued

DATE ISSUED: July 31, 2002

EFFECTIVE DATE: September 18, 2002

Aloa J. Stevens
Director – State Government Affairs
Citizens Communications Company
4 Triad Center, Suite 200
Salt Lake City, Utah 84180

ACCESS SERVICE

17. Arizona Universal Service Fund

17.1 Applicability

The surcharges set forth below relate to funding the Arizona Universal Service Fund (AUSF) and are in addition to the rates and charges for access service, toll service and local service set forth in the applicable tariffs. If the Company determines it has collected its annually assessed amount prior to the end of the calendar year, it will suspend collection of these surcharges for the remainder of that year, subject to any subsequent adjustment necessitated by Arizona Corporation Commission Order.

17.2 Elements and Rates

17.2.1 Access Portion Element

The surcharge amounts are per A.C.C. R-14-2-1201 through R14-2-1217. As the Arizona Corporation Commission issues orders, which increase or decrease the requirement for AUSF funding, this surcharge amount(s) will be adjusted accordingly.

(T)
|
(T)